

## AMPeLite PolyRib

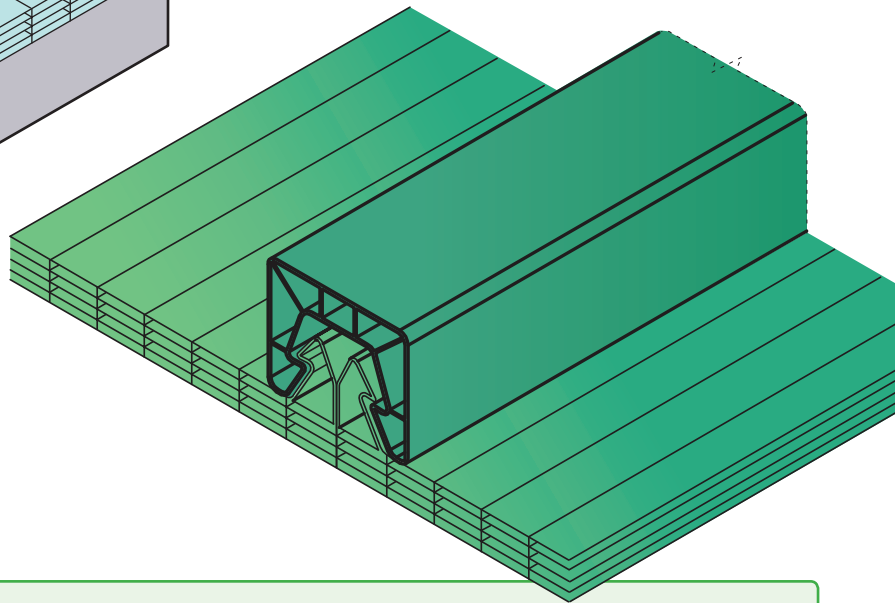

Liability clause: all the indications and technical consultancy provided is given in good faith and according to the best available knowledge; however, as we have no control over our own materials' use by others, all responsibility is declined for their applications. The indications do not exonerate the purchaser from carrying out his own checks in order to determine the compliance of the materials with his own requirements and with current applicable standards. Ampelite Australia Pty Ltd reserves the right to make modifications without prior notice to its own products and the contents of the documentation.

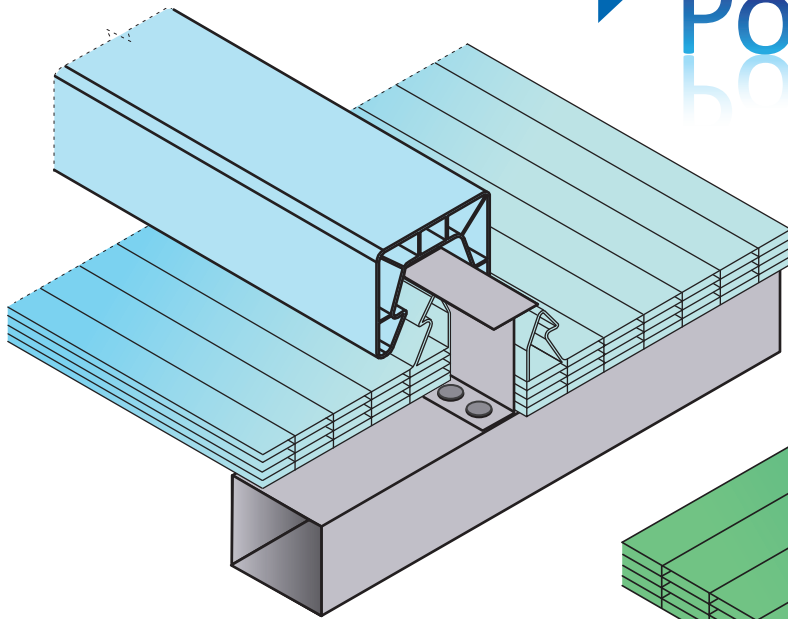

**VIC & TAS** Tel 03 8710 9110 Fax 03 9794 0710

**QLD** Tel 07 3382 8300 Fax 07 3200 8703

**SA & NT** Tel 08 8260 7391 Fax 08 8260 7397

**NZ** Tel 09 634 5366 Fax 09 622 2060

**NSW & ACT** Tel 02 9625 7200 Fax 02 9625 7211

**Nth QLD** Tel 07 4774 5007 Fax 07 4774 7898

**WA** Tel 08 9302 6833 Fax 08 9302 6855

[www.ampelite.co.nz](http://www.ampelite.co.nz)

## BEFORE STARTING:

### STORAGE:

PROTECT SHEETS FROM SUN AND RAIN

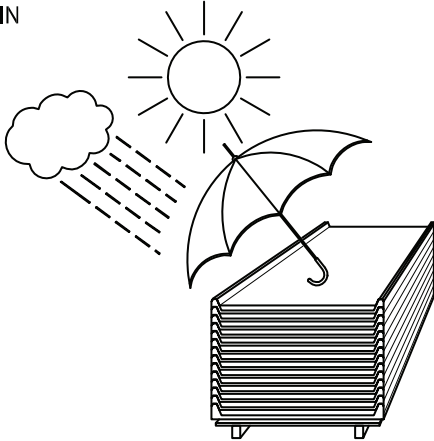

### PROTECT SIDE:

AMELITE PolyRib IS UV PROTECTED ON BOTH SIDES

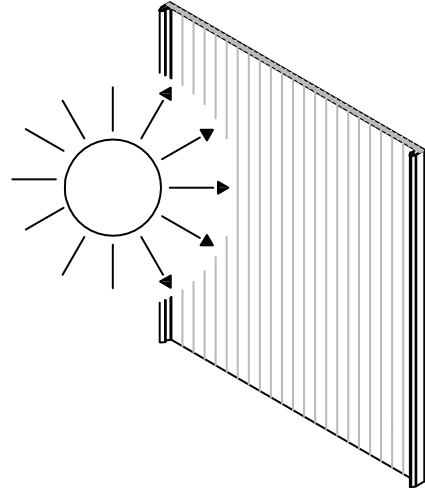

### SAFETY:

IT IS FORBIDDEN TO WALK ON AMELITE PolyRib POLYCARBONATE SHEETS

DO NOT WALK ON SHEETS BEFORE AND AFTER THE INSTALLATION

DURING THE INSTALLATION USE ALL SAFETY DEVICES PROVIDED BY LAWS IN FORCE

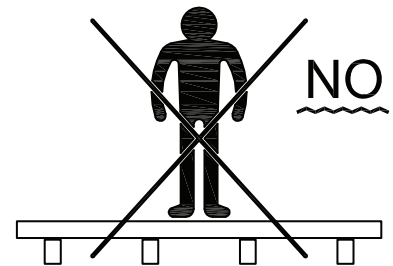
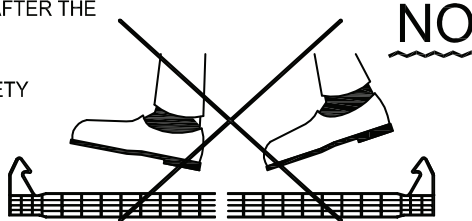

### CARE OF THE PRODUCT:

POLYCARBONATE SUFFERS THE CHEMICAL AGGRESSION OF CERTAIN PRODUCTS SO:

#### 1. SILICONE:

USE ONLY POLYCARBONATE COMPATIBLE SILICONE

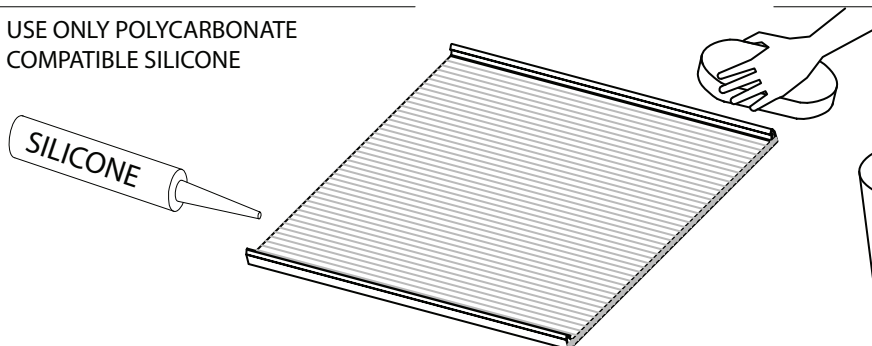

#### 2. CLEANING OF SHEETS:

FOR THE CLEANING OF THE SHEETS USE WATER

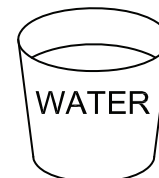

#### 3. GASKETS :

DO NOT USE TARRED OR BITUMINOUS GASKETS

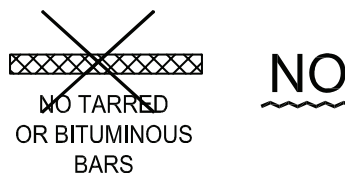



AMPELITE PolyRib SHEET



FASTENING CLAMP IN STAINLESS STEEL



POLYCARBONATE CLOSING CAP



POLYCARBONATE JOINING STRIP

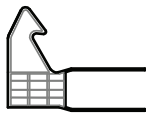

POLYCARBONATE EDGE CLOSURE

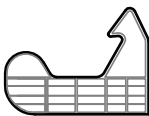

POLYCARBONATE END STRIP

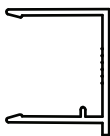

TOP & BOTTOM CLOSING CHANNEL IN  
ANODISED ALUMINIUM

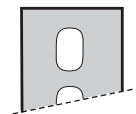

BREATHER TAPE

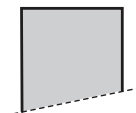

SEALING TAPE

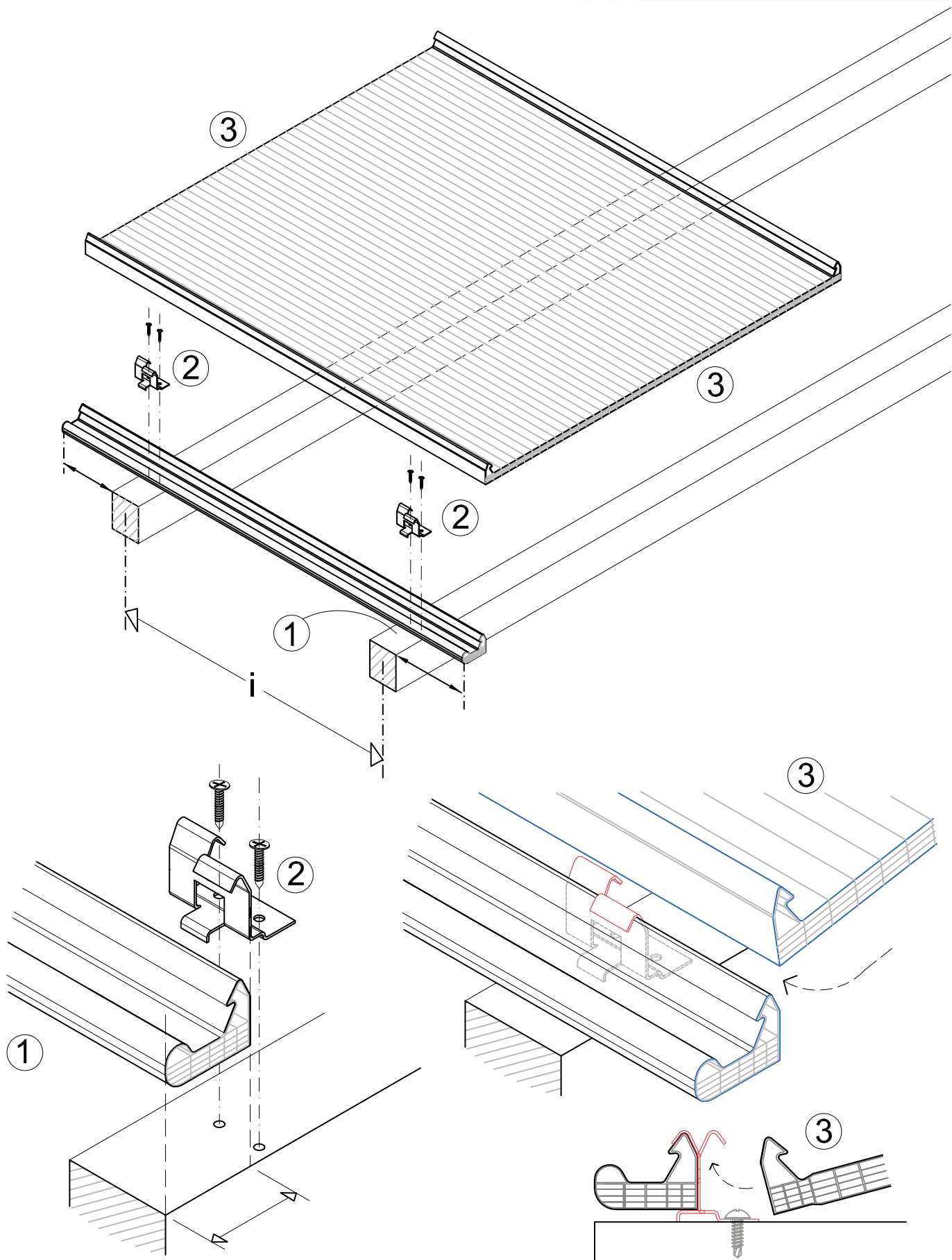

## INSTALLATION

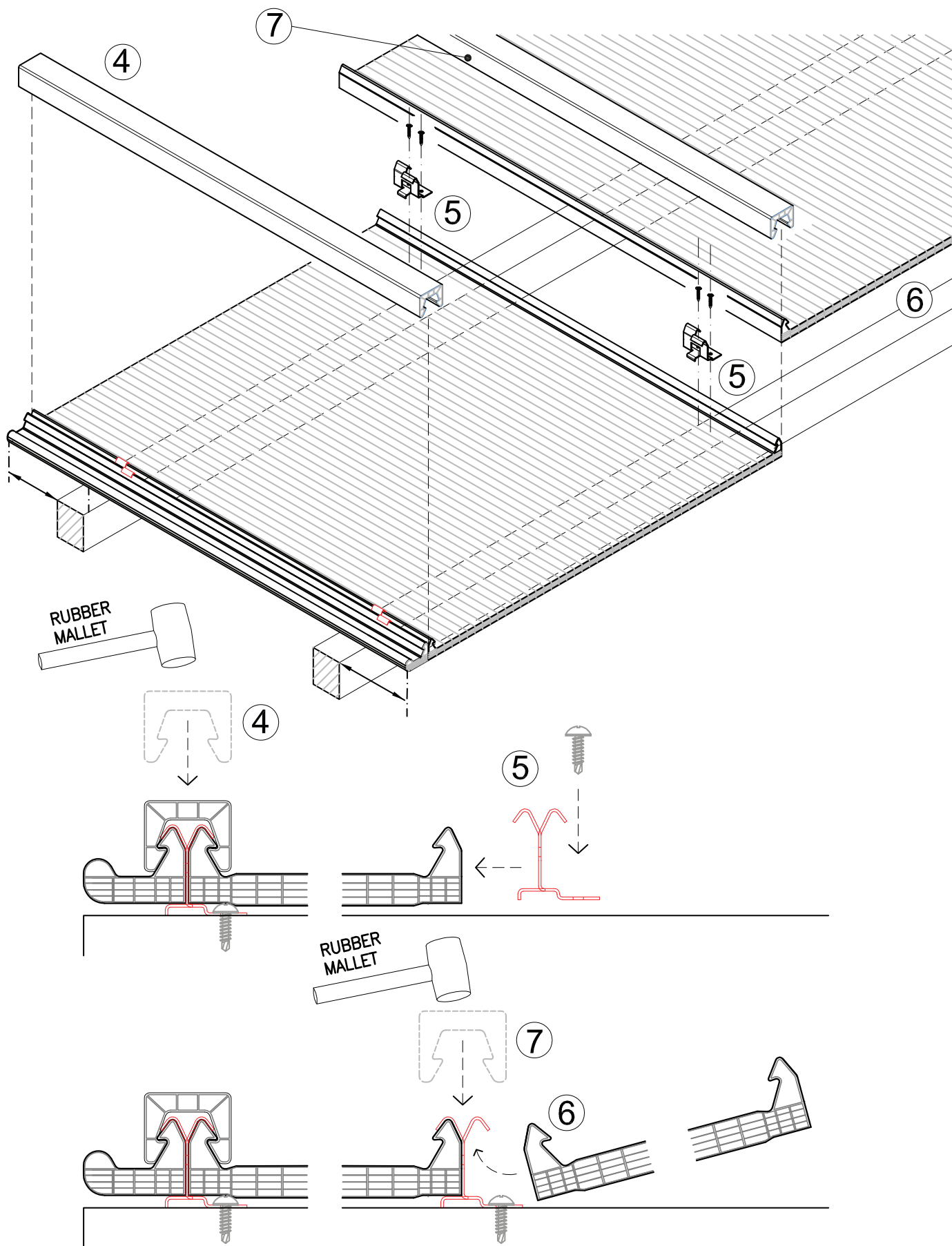

## INSTALLATION

