

MIXFLO PRO-SERIES INLINE MIXED FLOW FANS

FAN MODELS

Duct Size	Model	Switching	Speed Setting	Performance @ High Speed	Order Code
100mm	MF100S	Standard	2 Speed	69 l/s, 250m ³ /hr	FAN1004
100mm	MF100T	Timer	2 Speed	69 l/s, 250m ³ /hr	FAN2124
100mm	MF100PL	Plug & Lead	2 Speed	69 l/s, 250m ³ /hr	FAN1050
125mm	MF125S	Standard	2 Speed	89 l/s, 320m ³ /hr	FAN1005
125mm	MF125T	Timer	2 Speed	89 l/s, 320m ³ /hr	FAN2125
125mm	MF125PL	Plug & Lead	2 Speed	89 l/s, 320m ³ /hr	FAN1051
150mm	MF150S	Standard	2 Speed	166 l/s, 597m ³ /hr	FAN1006
150mm	MF150PL	Plug & Lead	2 Speed	166 l/s, 597m ³ /hr	FAN1048
200mm	MF200S	Standard	3 Speed	272 l/s, 980m ³ /hr	FAN1007
200mm	MF200T	Timer	2 Speed	272 l/s, 980m ³ /hr	FAN2127
200mm	MF200PL	Plug & Lead	3 Speed	272 l/s, 980m ³ /hr	FAN1053



MixFlo 150mm Standard Model - White

- These powerful inline mixed flow fans have been designed to produce higher working pressures for applications that require higher airflows with low relative noise levels.
- Supported by a 4 year warranty or 30,000 continuous hours.

DIMENSION INFORMATION (MM)

Model	A	B	C	D	E	F	G
MF100	98	182	315	100	100	168	27
MF125	122	182	350	100	100	168	60
MF150	147	209	360	130	115	195	55
MF200	197	244	354	142	140	230	50

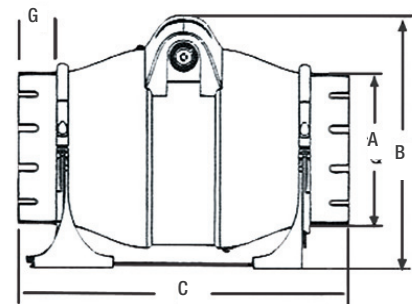
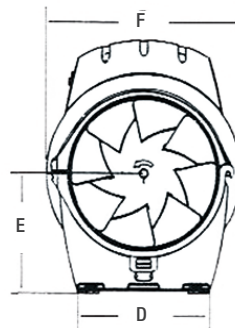

Dimensions - MF

Switching Options

1. Standard - Operates from remote switch (not supplied).
2. Timer - Fan operates from a switch and continues to run for a preset time after switching off - adjustable 1-20 minutes.

Requires three wires: permanent phase, switched phase, neutral.

NOTE: All fan flow rates quoted are free air delivery.

SOUND POWER LEVELS

Model	Sound Power Levels LwA (dB) Octave band centre frequency in Hz						
	125	250	500	1000	2000	4000	8000
MF100	50	56	58	58	52	47	37
MF125	52	59	60	60	56	49	41
MF150	58	66	65	63	62	54	46
MF200	65	69	64	63	62	60	48

TECHNICAL SPECIFICATION & PERFORMANCE DATA

Model	Size (mm)	RPM	Watts	Maximum Airflow (m ³ /hr)	Maximum Pressure (Pa)	Lp dB(A) 3m*	IP Rating	Max Operating Temp °C
MF100	100	2300	40	250	180	40	X4	45
		1700	18	190	120	33		
MF125	125	2300	40	320	220	43	X4	45
		1700	18	260	160	36		
MF150	150	2700	70	597	300	47	X4	60
		2000	60	330	240	40		
		2700	85	980	250	48		
MF200	200	2350	60	860	140	45	X4	60
		2000	45	706	80	41		

* Lp dB(A) @ 3 metres - sound pressure based on the high speed for each fan.

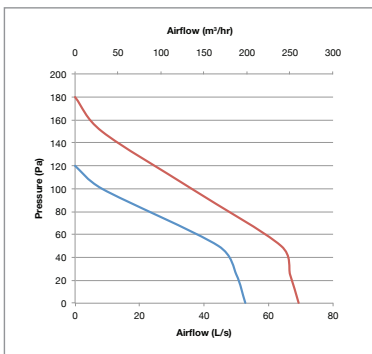

Performance - MF100

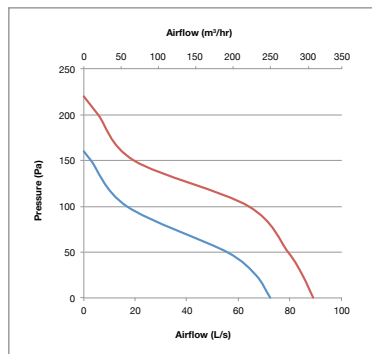

Performance - MF125

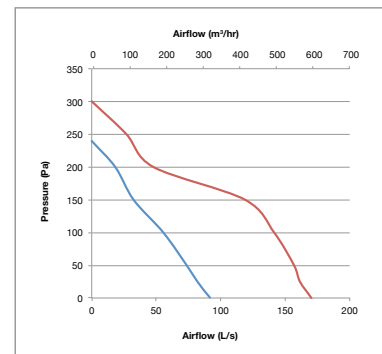

Performance - MF150

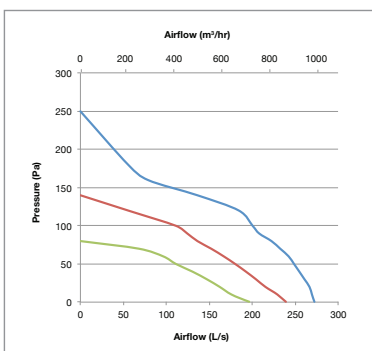

Icon Key

- Speed 1 —
- Speed 2 —
- Speed 3 —

Performance - *MF200

*MF200 Timer model only has 2 speeds, therefore Medium fan speed specifications will not apply.