

Building wrap and flexible flashing tape.  
Flexible flashing tape to be continuous  
along sill, 100mm min. up each jamb and  
50mm onto face of building wrap.

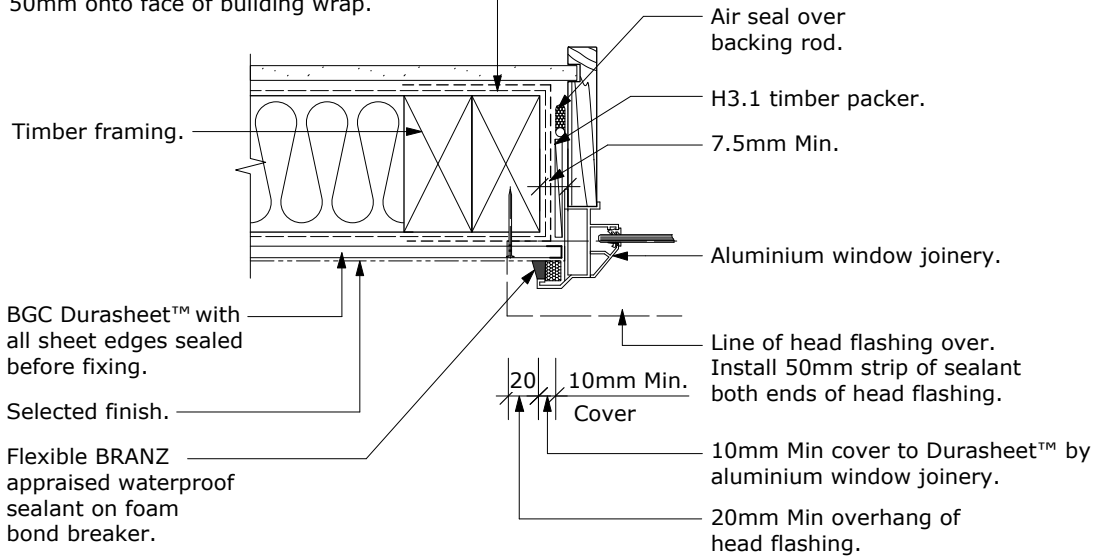

### Direct Fix

Building wrap and flexible flashing tape.  
Flexible flashing tape to be continuous  
along sill, 100mm min. up each jamb and  
50mm onto face of building wrap.

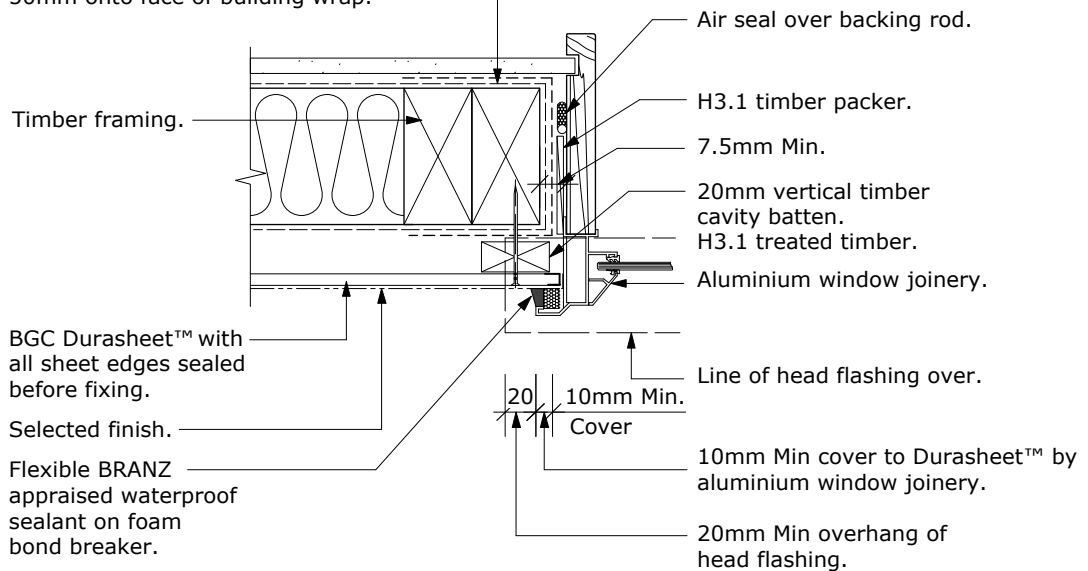

### Cavity

PROFILE **BGC Durasheet™**

DATE Feb 2010

DETAIL **Window Jamb Details**

SCALE 1:5 @ A4

DETAIL NO. **D 23**