

# Technical Specification

# Contents

<b>1</b>	<b>APPLICATION AND SCOPE</b>	<b>3</b>	<b>6</b>	<b>PANEL FIXING</b>	<b>7</b>
1.1	Application	3	6.1	General	7
1.2	Scope	3	6.2	Fastener Durability	7
1.3	Details	3	6.3	Fastener — Type, Size and Layout	7
1.4	Specific Design	3	6.4	Panel Layout	8
<b>2</b>	<b>DESIGN</b>	<b>3</b>	<b>7</b>	<b>JOINTING</b>	<b>8</b>
2.1	Compliance	3	7.1	General	8
2.2	Responsibility	3	7.2	Vertical Joint	8
2.3	Site and Foundation	3	7.3	Horizontal Joint	9
2.4	Surface Clearances	4	7.4	External Corner	9
2.5	Moisture Management	4	7.5	Internal Corner	9
2.6	Structure	4	7.6	Flashing Material Durability	9
2.7	Bracing	4	<b>8</b>	<b>FINISHING</b>	<b>9</b>
2.8	Fire Rated Walls	4	8.1	Preparation	9
2.9	Energy Efficiency	4	8.2	Flexible Sealants	9
<b>3</b>	<b>FRAMING</b>	<b>5</b>	<b>9</b>	<b>STORAGE AND HANDLING</b>	<b>9</b>
3.1	General	5	<b>10</b>	<b>MAINTENANCE</b>	<b>10</b>
3.2	Timber Framing	5	<b>11</b>	<b>PRODUCT INFORMATION</b>	<b>10</b>
3.3	Steel Framing	5	11.1	Manufacturing and Classification	10
3.4	Construction Methods	5	11.2	Product Mass	10
3.5	Tolerances	5	11.3	Durability	10
<b>4</b>	<b>PREPARATION</b>	<b>5</b>	<b>12</b>	<b>SAFE WORKING PRACTICES</b>	<b>11</b>
4.1	Flexible Underlay or HomeRAB™ Pre-Cladding	5	<b>13</b>	<b>PRODUCT SIZES AND ACCESSORIES</b>	<b>13</b>
4.2	Rigid Air Barrier	5	<b>14</b>	<b>DETAILS</b>	<b>15</b>
4.3	Vent Strip	5	<b>6</b>	<b>PRODUCT WARRANTY</b>	<b>51</b>
4.4	Flashings	6			
4.5	Junctions and Penetrations	6			
<b>5</b>	<b>BATTEN INSTALLATION</b>	<b>6</b>			
5.1	CLD Structural Cavity Battens	6			
5.2	Batten Layout	6			
5.3	Intermediate Support	6			
5.4	Batten Fasteners	6			

## WE VALUE YOUR FEEDBACK

To continue with the development of our products and systems, we value your input. Please send any suggestions, including your name, contact details, and relevant sketches to:

**Ask James Hardie™**  
literaturefeedback@jameshardie.co.nz

**THIS TECHNICAL SPECIFICATION IS FOR AXON™ PANEL DIRECT FIXED AND FIXED TO CLD™ STRUCTURAL CAVITY BATTEN.**

# 1 Application and scope

## 1.1 APPLICATION

---

Axon™ Panel is manufactured by James Hardie using an advanced lightweight cement composite. Base composition is portland cement, ground sand, cellulose fibre and water. Axon Panel has vertical grooves along the panel. It is classified as lightweight wall cladding suitable for residential and light commercial buildings using timber framing.

- Axon Panel is ideal for achieving feature walls in areas such as gable ends and entrance ways.
- Axon Panel is primed on the face to take a suitable paint finish in any colour.
- Axon Panel 133 Smooth - the grooves on the face panel are nominal 10mm wide x 2.25mm deep and spaced at 133mm centres.
- Axon Panel 133 Grained - the grooves on the face panel are nominal 10mm wide x 2.25mm deep and spaced at 133mm centres. Between the grooves is a look of traditional wood-grain texture.
- Axon Panel 400 Smooth - the grooves on the face panel are nominal 10mm wide x 2.25mm deep and spaced at 400mm centres.

### Specifier

If you are a specifier or other responsible party for a project, ensure that the information in this document is appropriate for the application you are planning and that you undertake specific design and detailing for areas which fall outside the scope of these specifications.

### Installer

If you are an installer ensure that you follow the design, moisture management principles, associated details and material selection provided by the designer. All of the details provided in this document must be read in conjunction with this specification.

### Make sure your information is up to date

When specifying or installing James Hardie products, ensure you have the current manual. If you're not sure you do, or you need more information, visit [www.jameshardie.co.nz](http://www.jameshardie.co.nz) or Ask James Hardie™ on 0800 808 868.

## 1.2 SCOPE

---

The scope of this specification for the use of Axon Panel is limited to buildings which fall within the scope limitations of 'Acceptable Solution E2/AS1 paragraph 1.1' of the New Zealand Building Code (NZBC).

This document is intended for use by architects, designers and specifiers who may be involved with the specification of Axon Panel.

This manual covers the use of Axon Panel for both construction methods i.e. direct fixed to framing or cavity construction, used in external walls of timber framed buildings up to 2.5kPa.

Please refer to E2/AS1 for further information regarding the selection of construction methods to be used for fixing claddings.

## 1.3 DETAILS

---

Various Axon Panel figures are provided in the Details section of this document. This specification and details in dwg, dxf, jpg and pdf file format are also available for download at [www.jameshardie.co.nz](http://www.jameshardie.co.nz).

All dimensions shown are in millimetres unless noted otherwise.

## 1.4 SPECIFIC DESIGN

---

For use of Axon Panel outside this published scope, the architect, designer or engineer must undertake specific design.

For advice on designs outside the scope of this specification, Ask James Hardie on 0800 808 868.

# 2 Design

## 2.1 COMPLIANCE

---

Axon Panel complies with E2 of the NZBC as an alternate solution.

Axon Panel cladding has been tested as per E2/VM1 of the NZBC and it passes the test performance requirements. Axon Panel also complies with durability requirements of 'B2' clause of the NZBC.

## 2.2 RESPONSIBILITY

---

The specifier or other party responsible for the project must run through a risk matrix analysis to determine which construction method is to be used. The designer must also ensure that the figures published in this specification are appropriate for the intended application and that additional detailing is performed for specific design or any areas that fall outside the scope of this specification. The designers should ensure that the intent of their design meets the requirements of the NZBC.

All New Zealand Standards referenced in this manual are current edition and must be complied with.

James Hardie conducts stringent quality checks to ensure that any product manufactured falls within our quality spectrum. It is the responsibility of the builder to ensure that the product meets aesthetic requirements before installation. James Hardie will not be responsible for rectifying obvious aesthetic surface variations following installation.

## 2.3 SITE AND FOUNDATION

---

The site on which the building is situated must comply with the NZBC Acceptable Solution E1/AS1 'Surface Water'.

Foundations design must comply with the requirements of NZS 3604 'Timber-framed Buildings' or be as per specific engineering design.

The grade of adjacent finished ground must slope away from the building to avoid any possibility of water accumulation in accordance with the NZBC requirements.

## 2.4 SURFACE CLEARANCES

The clearance between the bottom edge of cladding and paved/unpaved ground must comply with section 9.1.3 of E2/AS1. The finished floor level must also comply with these requirements. These clearances must be maintained throughout the life of the building.

Axon Panel must overhang the bottom plate on a concrete slab by a minimum of 50mm as required by NZS 3604.

Axon Panel must have a minimum clearance of 100mm from paved ground, and 175mm from unpaved ground. On roofs and decks, the minimum clearance must be 50mm.

Do not install external cladding such that it may remain in contact with water or ground. Refer Figures 3 and 18.

## 2.5 MOISTURE MANAGEMENT

It is the responsibility of the specifier to identify moisture related risks associated with any particular building design.

Wall construction design must effectively manage moisture, considering both the interior and exterior environments of the building, particularly in buildings that have a higher risk of wind driven rain penetration or that are artificially heated or cooled.

Walls must include those provisions as required by the NZBC Acceptable Solution E2/AS1 'External Moisture'. In addition all wall openings, penetrations, junctions, connections, window sills, heads and jambs must incorporate appropriate flashings for waterproofing. The other materials, components and installation methods used to manage moisture in external walls, must comply with the requirements of relevant standards and the NZBC.

For further guidance on designing for weathertightness refer to BRANZ Ltd, and the Ministry of Business Innovation and Employment (MBIE) updates on the following websites respectively, [www.branz.co.nz](http://www.branz.co.nz) and [www.building.govt.nz](http://www.building.govt.nz)

## 2.6 STRUCTURE

### 2.6.1 Timber framing

Timber-framed buildings must be designed in accordance with NZS 3604 (Timber-framed Buildings). When the framing is provided as per the specific engineering design, the framing stiffness must be either equivalent to or more than the stiffness requirements of NZS 3604.

For timber frame walls longer than 12m it is best practice to allow for construction joints to accommodate movements generated due to timber shrinkage or deflections etc.

### 2.6.2 Wind loading

Axon Panel is suitable for use in all wind zones in New Zealand up to and including EH as defined in NZS 3604.

A specific design is required for all situations where the buildings falls outside the scope of NZS 3604 and E2/AS1.

## 2.7 BRACING

Axon Panel direct fixed can be used to achieve structural bracing when fixed with stainless steel HardieFlex™ nails. For further information refer to the James Hardie Bracing Design Manual.

Axon Panel installed to CLD™ Structural Cavity Battens as per this specification cannot be used to achieve structural bracing. However, bracing can be achieved by using James Hardie rigid air barrier board installed direct to framing instead of a flexible underlay or by using Villaboard® Lining bracing system on the internal face.

## 2.8 FIRE RATED WALLS

Axon Panel when direct fixed with HardieFlex nails to external walls can achieve fire ratings up to 60/60/60 to comply with C/AS1 of the NZBC when the walls are constructed in accordance with the current James Hardie 'Fire and Acoustic Design Manual'.

When using Axon Panel fixed to CLD Structural Cavity Battens, a fire rating of up to 60 minutes can be achieved using RAB® Board in conjunction with the fire rated system requirements as specified in the James Hardie 'Fire and Acoustic Design Manual'. Ask James Hardie on 0800 808 868 for further information.

Axon Panel is classified as a non-combustible material suitable for use on walls close to boundary.

## 2.9 ENERGY EFFICIENCY

External walls constructed as per this technical specification using Axon Panel, bulk insulation, where the area of glazing is 30% or less of the total wall area comply with the requirements for walls in the NZBC Acceptable Solution H1/AS1 (NZBC Clause H1 Energy Efficiency), Replacement Table 1. To meet thermal insulation requirements for the construction, the bulk insulation as specified in Table-1 must be used. This insulation may be substituted with insulations having higher R-values. The thermal insulation of a wall gets affected when the depth of the timber framing is increased or decreased. The calculation used in Table 1 is based on a timber framing size 90 x 45mm and using an internal lining material such as James Hardie Villaboard® Lining or a 10mm plasterboard.

Table 1

Insulation capability		
Climate Zone	Construction R-Value Requirement	Minimum R-Value of Insulation Required
1 and 2	1.9 m <sup>2</sup> °C/W	#R2.0
3	2.0 m <sup>2</sup> °C/W	#R2.2
<p>Total construction R-Value depends on the insulation material used and the framing ratio. The insulation material R-Values specified in this table are for studs spaced at 600mm c/c and nogs spaced at 800mm c/c.</p> <p># To achieve higher R-Values of construction the wall insulation material must be replaced with an insulation material having higher R-Values to suit the requirements.</p> <p>For further guidance on insulation requirements refer to the current edition of 'House Insulation Guide' published by BRANZ.</p>		

# 3 Framing

## 3.1 GENERAL

---

This Axon Panel technical specification is only suitable for timber-framed buildings. Other framing materials are subject to a specific engineering design.

## 3.2 TIMBER FRAMING

---

### 3.2.1 Dimensions

A minimum 45mm wide stud is required.

### 3.2.2 Structural grade

Minimum timber grade requirement is No. 1 framing grade or MSG6 as per NZS 3604. The grading of timber must comply with the AS/NZS 1748 and NZS 3631 requirements.

### 3.2.3 Durability

The external framing must be treated to a minimum H1.2 treatment. Refer to the NZBC Acceptable Solution B2/AS1 'Durability' for further information about the durability requirements.

For timber treatment and allowable moisture content information refer to NZS 3602 (Timber and Wood-Based Products for use in Buildings) and NZS 3640 (Chemical Preservation of Round Sawed Timber) for minimum timber treatment selection and treatment requirements.

Also refer to the framing manufacturer's literature for further guidance on timber selection. Framing must be protected from moisture at site in accordance with the recommendation of the framing manufacturers.

### 3.2.4 Frame construction

The framing must fully support all panel edges. The framing must be rigid and not rely on the cladding panel for stability.

Timber framing sizes and its set-out must comply with NZS 3604 and as specified in this specification.

In case of gable end trusses sitting on top plates of the external wall frame, the frame size must comply with the minimum timber sizes stipulated for wall frames in Section 8 of the NZS 3604.

For timber frame walls longer than 12m, it is best practice to allow for construction joints to accommodate movements generated due to timber shrinkage or deflections generated by loadings etc.

## 3.3 STEEL FRAMING

---

Refer to James Hardie Steel Frame Technical Specification about the installation of Axon Panel to steel frame.

## 3.4 CONSTRUCTION METHODS

---

### 3.4.1 Direct fixed

For direct fixed construction method the following framing is required:

- Studs at 600mm c/c maximum
- A minimum 45mm stud width is required at vertical panel joints
- Nogs/dwangs are required at 1200mm c/c maximum.

### 3.4.2 CLD Structural Cavity Batten

For cavity construction method the following framing is required:

- When studs are spaced at 600mm centres maximum, the nogs/dwangs must be provided at 800mm centres maximum
- When studs are spaced at 400mm centres then the nogs/dwangs may be provided at 1200mm centres
- An extra stud is required in internal corners. Refer to Figure 21.

## 3.5 TOLERANCES

---

In order to achieve the required performance and an acceptable wall finish, it is imperative that framing is straight and true.

Framing tolerances must comply with the requirements of NZS 3604. All framing shall be made flush.

# 4 Preparation

## 4.1 FLEXIBLE UNDERLAY OR HOMERAB PRE-CLADDING

---

Flexible underlay or HomeRAB® Pre-Cladding must be provided as per the requirements of the NZBC Acceptable Solution E2/AS1 'External Moisture' and NZS 3604. The flexible underlay must comply with Table 23 of E2/AS1 and AS/NZS 4200.1. The flexible underlay must be fixed in accordance with E2/AS1, NZS 3604 and AS/NZS 4200.2 and the underlay manufacturer's recommendations.

Walls which are not lined on the inside face (e.g. garage walls or gable ends) must include a rigid sheathing or an air barrier behind the cladding which complies with the requirements of the NZBC Acceptable Solution E2/AS1 Table 23. For attached garages, flexible underlays must be selected in accordance with the NZBC Acceptable Solution E2/AS1, paragraph 9.1 3.4. HomeRAB Pre-Cladding is suitable for use in these applications. It must be installed in accordance with the James Hardie Rigid Air Barriers installation manual.

## 4.2 RIGID AIR BARRIER

---

For EH wind zone or Specific Engineering Design projects where the wind pressures are higher than 1.5kPa (ULS), RAB Board (6mm) must be used. Refer to the James Hardie rigid air barriers installation manual for information regarding its installation. For buildings within the scope NZS 3604 HomeRAB Pre-Cladding Lining (4.5mm) or flexible underlays can be used.

## 4.3 VENT STRIP

---

The James Hardie uPVC cavity vent strip must be installed at the bottom of all walls constructed using the drained and ventilated cavity construction method. It is important that the openings in the vent strip are kept clear and unobstructed to allow free drainage and ventilation of cavities. James Hardie uPVC vent strip has an opening area of 1000mm<sup>2</sup>/m length.

## 4.4 FLASHING

---

All wall openings, penetrations, intersections, connections, window sills, heads and jambs must be flashed prior to panel installation. Please refer to moisture management requirements in Clause 2.5. The flexible underlay or RAB Board must be appropriately taped around the penetrations and lapped/taped to flashings. Materials must be lapped in such a way that water tracks down to the exterior of a building. James Hardie will assume no responsibility for water infiltration within the wall due to poor installation of flashings or flexible underlays. The selected flashing materials must comply with the durability requirements of the NZBC. For information refer to Table 20 of clause E2 of the NZBC.

When using a James Hardie rigid air barrier board the entire framing around window opening must be sealed with a flashing tape. The tape must be finished over the face of James Hardie rigid air barrier board. The flashing tapes like SUPER-STICK Building Tape® by Marshall Innovations or 3M™ All Weather Flashing Tape 8067 by 3M™ are recommended for use with James Hardie rigid air barrier board. Refer to the tape manufacturer's literature for further information regarding their installation.

## 4.5 JUNCTIONS AND PENETRATIONS

---

Refer to Clause 2.5 of this specification for moisture management requirements. All windows and doors must be detailed as per the requirements of this specification. James Hardie has developed the window details for Axon Panel which meet the requirements of E2 'External Moisture', an approved document of the NZBC. Refer to Figures 8 to 10 and 24 to 26.

# 5 Batten installation

Note: This specification is not for timber cavity battens. Refer to separate technical specification from James Hardie.

## 5.1 CLD STRUCTURAL CAVITY BATTENS

---

Buildings with a risk score of 7-20 calculated in accordance with Table 2 of Acceptable Solution E2/AS1 of the NZBC, require Axon Panel to be installed on a cavity. CLD Structural Cavity Battens provide airspace between the frame and the panel and are used to fix cladding into them.

CLD Structural Cavity Battens are made of a low density fibre cement formulation which enables them to have extra strength and durability. CLD Structural Cavity Batten is sealed on all sides and is suitable to fix Axon Panel installed as per this technical specification, and it can withstand the design wind pressures exerted on a cladding within the scope of NZS 3604.

The CLD Structural Cavity Battens are made 2450mm long and 19mm thick. The battens are fully sealed on all sides.

## 5.2 BATTEN LAYOUT

---

CLD Structural Cavity Battens must be fixed to the wall framing over flexible underlay or James Hardie rigid air barrier. The smoother face of batten should face towards the cladding.

CLD Structural Cavity Battens are suitable to withstand wind pressures up to 2.5kPa (ULS). For batten fixing, refer to section 5.4. Ensure the battens are straight and provide a flat surface to fix Axon Panel to. Site cut ends of battens must be sealed on site with Dulux® Acraprime 501/1 sealer or Resene Quick Dry.

The battens are run continuously over the studs but they must not be run continuously over the floor joists. There must be a 15mm gap between the battens at floor joist level to allow for structural shrinkages and deflections. Refer to Figure 27.

CLD Structural Cavity Battens can be butt jointed over the studs within the floor height. The batten ends must be cut between 20° to 45° and be installed in a way that the butt joint deflects the moisture to the exterior. The ends must be sealed and jointed with the adhesive sealant before butting them together. Refer to Figure 23.

The designer must ensure that the CLD Structural Cavity Battens are not used in situations where design wind pressures are above 2.5kPa (ULS).

CLD Structural Cavity Battens must always be at least 300mm in length.

## 5.3 INTERMEDIATE SUPPORT

---

Where studs are at 600mm centres an intermediate means of restraining the flexible underlay and insulation from bulging into the cavity shall be installed. An acceptable method to achieve this is using a:

- 75mm galvanised mesh; or
- polypropylene tape at 300mm centres fixed horizontally and drawn taut.

No intermediate supports are required:

- when studs are spaced at 400mm centres; or
- when RAB Board instead of flexible underlays are used.

## 5.4 BATTEN FASTENERS

---

The CLD Structural Cavity Batten must be fixed to the framing as specified in Table 2. The fasteners must be driven at a minimum distance of 50mm from the batten ends.

Table 2

Batten fixing				
Fixing Type	Framing	Basic Wind Pressure kPa (ULS)	Batten centres max. (mm)	Fixings centres max. (mm)
65mm x 2.8mm RounDrive ring shank nail hot dip galv./ s.steel	Timber	Up to 1.5 (Up to and including VH wind zone)	600	250
		Up to 2.5 (>VH wind zone)	400	200
50mm x 9-10g Countersunk head steel screw class 3/4	*Steel 0.55 to 1.6mm BMT	Up to 1.5 (Up to and including VH wind zone)	600	250
		Up to 2.5 (>VH wind zone)	400	200

For fastener durability information, refer to Clause 6.2 of this document.

CLD Structural Cavity Battens less than 400mm in height must have fixings at maximum 150mm centres.

Battens must be fixed over studs.

## 6 Panel fixing

### 6.1 GENERAL

Axon Panel must be kept dry and under cover whilst in storage or during the installation. Every endeavour must be made to keep framing dry once panel fixing commences. All site-cut panel edges must be sealed prior to installation.

- The shiplap jointing of panels is only suitable for vertical fixing of panels.
- Do not fix in the groove of Axon Panel.
- Ensure the sheets are from the same batch.
- It is recommended to fix from the centre of the panel and work outwards.
- Do not overdrive fasteners.
- Fixings must be finished flush with the panel surface.

### 6.2 FASTENER DURABILITY

Fasteners must meet the minimum durability requirements of the NZBC. NZS 3604 specifies the requirements for fixing material to be used in relation to exposure conditions and are summarised in Table 3.

Table 3

Exposure conditions and nail selection prescribed by NZS 3604		
NAIL MATERIAL		
Zone D*	Zone C* outside sea spray zone, Zone B and Geothermal hot spots	Bracing — All Zones
Grade 316 Stainless	Hot-dipped galvanised or Grade 316 stainless	Grade 316 Stainless

\*Zone C areas where local knowledge dictates that increased durability is required, appropriate selection shall be made). Microclimate conditions as detailed in NZS 3604, paragraph 4.2.4 require SED.

Also refer to the NZBC Acceptable Solution E2/AS1 Table 20 and 21 for information regarding the selection of suitable fixing materials and their compatibility with other materials.

### 6.3 FASTENER – TYPE, SIZE AND LAYOUT

#### 6.3.1 Direct fix

Axon Panel must be fixed to framing using the fixings as specified in Table 4 below and follow the edge distance required for nails as shown in the details. Refer to Figures 2 and 4.

Table 4

Panel fixing		
DIRECT FIXED TO FRAME USING HARDIEFLEX NAILS OVER FLEXIBLE UNDERLAY		
40 x 2.8mm HardieFlex nails.	Fix @ 200mm centres to all framing. Stud width 45mm min. required at vertical joint.	
DIRECT FIXED TO FRAME USING BRAD NAIL OVER FLEXIBLE UNDERLAY		
ND 50 stainless steel straight brad nail	Up to 1.5kPa (Up to and including VH wind zone)	Fix 150mm c/c on panel edges and intermediate framing

Notes:

1. Brad nail fixing method is only suitable up to very high wind speed zones. Do not use this method for EH wind zones described in NZS 3604 or SED projects.
2. Nails must be finished flush with panel surface.
3. Special fixing arrangements are required for bracing and fire-resistance rated wall systems.

For more information Ask James Hardie on 0800 808 868.

When fixing the panels using nail guns, refer to the nail gun manufacturer for information about nails and the type of nail gun to be used.

Note: Do not use 'D' head nails.

### 6.3.2 CLD Structural Cavity Batten Method

This panel fixing method can be used up to 2.5kPa wind pressure. Axon Panel is only fixed into the CLD Structural Cavity Batten as per this method.

#### Adhesive sealant

A polyurethane adhesive sealant Seal N Flex-1 manufactured by Bostik or SikaFlex 11FC by Sika are recommended for use in the installation of these products. Apply a 6mm continuous bead of this adhesive sealant over the face of the CLD Structural Cavity Batten before fixing the Axon Panel. Refer to Figure 19, 20 and 21.

When using external box corner flashing, use a 10mm thick bead of adhesive over the aluminium box corner flanges. Refer to Figure 22.

Note: Do not use excessive adhesive.

### 6.3.3 Cavity construction using timber cavity battens

When fixing Axon Panel using timber cavity battens, these details are available at [www.jameshardie.co.nz](http://www.jameshardie.co.nz) or Ask James Hardie on 0800 808 868.

## 6.4 PANEL LAYOUT

All panel edges must be supported by the framing. The shiplap joint must be formed vertically. The framing centers must be checked before the panel installation.

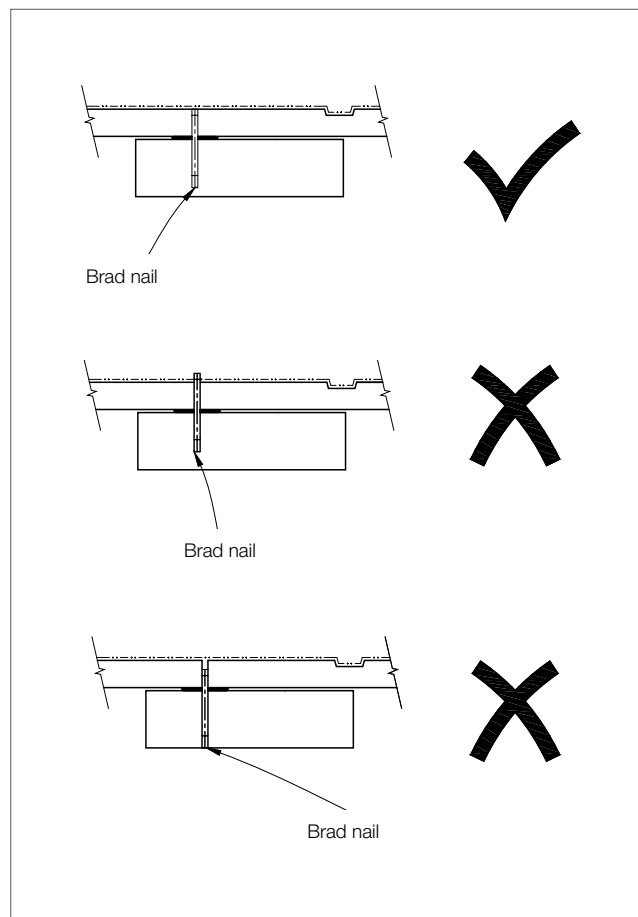

Fix Axon Panel to CLD Structural Cavity Battens using one of the following fixings specified in Table 5. The edge distance at panel corner must be minimum 75mm vertically from panel corners. Refer Figure 17.

Table 5

Axon Panel Fixing		
Types of fixings to be used with adhesive sealants	Suitable up to Basic Wind Pressure kPa (ULS)	Fixing to CLD Structural Cavity Battens c/c (mm)
C-25 straight 'T'- Head stainless steel brad nail	1.5 (Up to and including VH wind zone)	150
25 x 2.5mm annular threaded fibre cement nail	2.5 (> VH wind zone)	200
25mm x 10g counter sunk screw class 3/4 or stainless steel	2.5 (> VH wind zone)	200

Notes:

- Brad nail fixing method is only suitable up to 1.5kPa.
- Nails must be finished flush with panel surface.

# 7 Jointing

## 7.1 GENERAL

Axon Panels are fixed to form a shiplap joint at vertical edges. The panels have factory-made edges to suit this jointing.

## 7.2 VERTICAL JOINT

### Direct fixed

Axon Panels are shiplap jointed keeping a gap of 1-2mm between the panels. A 50mm wide 3259 Inseal sealing tape is used under the joint over the face of the timber stud where direct fixed construction method is used. A flexible sealant must be applied to the full length of the shiplap joint before the panels are jointed. The edge distance for a HardieFlex nail must be 18mm min. Refer to Figure 4.

### Cavity construction

Fix the CLD Structural Cavity Batten over the studs and it runs behind the entire length of the shiplap joint with a 50mm overhang below the bottom plate and finishes flush with the bottom edge of panel. Refer to Figures 16 and 17. The vertical shiplap joint is formed along the centre line of the batten. A bead of sealant is applied to the vertical edge of the Axon Panel to seal the shiplap joint before fixing the panels. Refer to Figure 19. The edge distance for a brad nail must be 16mm and 18mm. Refer Figures 14 and 19.



# 8 Finishing

## 7.3 HORIZONTAL JOINT

---

At floor joist levels a horizontal joint must be provided to accommodate the movement resulting from timber joist shrinkage and settlement. A JH 9mm panel aluminium horizontal 'h' mould is used to form a horizontal joint. Use the aluminium 'h' mould jointer to cover over the butt joint of 'h' mould. A purpose made metal 'Z' flashing or a James Hardie uPVC flashing could also be used to flash the horizontal joint. Refer to Figures 11, 12 and 27.

## 7.4 EXTERNAL CORNER

---

A JH 9mm panel aluminium box corner mould is used to form the external box corner. The site-cut sheet edges must be sealed before butting them into the box corner. Refer to Figure 7.

Do not run the box corner flashing continuously over the floor joist. On a two storey construction the aluminium box corner is finished under the aluminium 'h' mould. A uPVC corner under flashing must be used under the box corner when in this situation. Refer to Figure 12.

For CLD Structural Cavity Batten external corner refer to Figure 22.

The bead of adhesive must be 10mm thick to accommodate for the thickness of the aluminium.

## 7.5 INTERNAL CORNER

---

Direct fixed internal corner is formed using a uPVC corner under flashing or an 80mm wide Inseal sealing strip behind the panel edges. The joint is filled with the flexible sealant. Refer to Figure 6.

For CLD Structural Cavity Batten internal corner joint detail refer to Figure 21.

## 7.6 FLASHING MATERIAL DURABILITY

---

Please refer to Table 20 of E2/AS1 of the NZBC regarding the durability requirements of various flashing materials.

## 8.1 PREPARATION

---

Painting of Axon Panel is mandatory to meet the durability requirements of the NZBC and 15 year James Hardie product warranties. Axon Panel must be dry and free of any dust or grime before painting. The panels must be painted within 90 days of their installation. There is no restriction on the LRV of paint to be applied on the Axon Panel.

When using uPVC flashings, dark colours should be avoided as it will affect the durability of uPVC flashing. The LRV of paint must be above 40% when using uPVC flashings.

Dark paints can be used when using the aluminium flashings.

Panels are pre-primed and are suitable for site applied acrylic paints. Pre-finished panels can also be installed using exposed head fasteners.

In order to seal cut edges or sanded patches, Dulux 1 Step, Resene quick dry, Taubmans Underproof Acrylic Primer Undercoat or a similar product should be applied. The primer should be compatible with the paint to be used.

Where panels are fixed with brad nails, the nail heads must be finished flush with panel surface. The nail gun should be set to nail "proud" of the panel surface and nail heads to be manually finished flush with surface. The nail heads can be skimmed over with an exterior grade 2 part builders fill if required. The skimmed area must be primed prior to site-applied finishing.

For site-applied finishes where brad nails are used. James Hardie recommends an undercoat and a minimum of two coats of acrylic paint. Follow the paint manufacturer's recommendations to prepare the surface and to adequately cover and conceal the panel fixings.

## 8.2 FLEXIBLE SEALANT

---

All sealants used must comply with the relevant requirements of the NZBC. Their application and usage must be in accordance with manufacturer's instructions. Check with sealant manufacturer prior to coating over sealants. Some sealant manufacturers do not recommend coating over their products.

# 9 Storage and handling

When storing Axon Panel, boards must be laid flat on a smooth level surface. Edges and corners must be protected from chipping.

To ensure optimum performance, store panels under cover and keep dry prior to fixing. If the panels become wet, allow them to dry thoroughly before fixing.

Do not carry panels on the flat, carry in the vertical position to avoid excessive bending.

# 10 Maintenance

The extent and nature of maintenance will depend on the geographical location and exposure of the building. As a guide, it is recommended that basic normal maintenance tasks shall include but not be limited to:

- Washing down exterior surfaces every 6-12 months\*
- Re-applying of exterior protective finishes if necessary\*\*
- Maintaining the exterior envelope and connections including joints, penetrations, flashings and sealants that may provide a means of moisture entry beyond the exterior cladding.
- Cleaning out gutters, blocked pipes and overflows as required
- Pruning back vegetation that is close to or touching the building
- The clearance between the bottom edge of Axon Panel and the finished ground must always be maintained.

\*Do not use a water blaster to wash down the cladding.

\*In extreme coastal conditions or sea spray zones, wash every 3-4 months.

\*\*Refer to your paint manufacturer for washing down and recoating requirements related to paint performance.

# 11 Product information

## 11.1 MANUFACTURING AND CLASSIFICATION

---

Axon Panel is an advanced lightweight cement composite building product. The basic composition is portland cement, ground sand, cellulose fibre and water. The panels are easily identified by the name 'Axon Panel' printed at regular intervals on the back face of panel.

CLD Structural Cavity Battens are manufactured using a low density fibre cement formulation. The basic composition is Portland cement, ground sand, cellulose fibre and water and proprietary additives. The battens are sealed on all sides.

Axon Panel is manufactured to AS/NZS 2908.2 'Cellulose-Cement Products Part 2: Flat Sheets' (ISO 8336 'Fibre Cement Flat Panels') standards in New Zealand. James Hardie New Zealand Limited is an ISO 9001 'Telarc' certified manufacturer.

Axon Panel is classified Type A, Category 3 in accordance with AS/NZS 2908.2 "Cellulose-Cement Products".

For Safety Data Sheets (SDS) visit [www.jameshardie.co.nz](http://www.jameshardie.co.nz) or Ask James Hardie on 0800 808 868.

## 11.2 PRODUCT MASS

---

Axon Panel is manufactured in 9.0mm thickness and has a mass of 12.1kg/m<sup>2</sup> at EMC.

Axon Panel cladding is defined as a Light Weight Wall Cladding (not exceeding 30kg/m<sup>2</sup>) as per NZS 3604.

## 11.3 DURABILITY

---

### 11.3.1 General

Axon Panel installed as per this technical specification will meet the durability requirements for claddings as required under clause 'B2-Durability' of the NZBC.

### 11.3.2 Resistance to moisture/rotting

Axon Panel has demonstrated resistance to permanent moisture induced deterioration (rotting) and has passed the following tests in accordance with AS/NZS 2908.2:

- Heat Rain (Clause 6.5).
- Water Permeability (Clause 8.2.2).
- Warm Water (Clause 8.2.4).
- Soak Dry (Clause 8.2.5).

### 11.3.3 Control of External Fire Spread

Axon Panel is assessed as per Appendix C C7.1.1 and is classified as 'Non-Combustible Material' which is suitable for use as external wall cladding and complies with requirements of Paragraph 5.4 of the NZBC Acceptable Solution C/AS1 and Paragraph 5.8.1 of Acceptable Solutions C/AS2 to C/AS6 of the NZBC.

### 11.3.4 Alpine regions

In regions subject to freeze/thaw conditions, Axon Panel must not be in direct contact with snow or ice build up for extended periods, e.g. external walls in alpine regions must be protected where snow drifts over winter are expected.

The Axon Panel has been tested in accordance with AS/NZS 2908.2 Clause 8.2.3.

# 12 Safe working practices

## STAY HEALTHY WHEN WORKING WITH BUILDING PRODUCTS CONTAINING CRYSTALLINE SILICA

---

### Crystalline Silica

What is it? Why and when is it a health hazard?

### Crystalline Silica is

- Commonly known as sand or quartz
- Found in many building products e.g. concrete, bricks, grout, wallboard, ceramic tiles, and all fibre cement materials

### Why is Crystalline Silica a health hazard?

- Silica can be breathed deep into the lungs when present in the air as a very fine (respirable) dust
- Exposure to silica dust without taking the appropriate safety measures to minimise the amount being breathed in, can lead to a potentially fatal lung disease – silicosis – and has also been linked with other diseases including cancer. Some studies suggest that smoking may increase these risks.
- The most hazardous dust is the dust you cannot see!

### When is Crystalline Silica a health hazard?

- It's dangerous to health if safety protocols to control dust are not followed when cutting, drilling or rebating a product containing crystalline silica.
- Products containing silica are harmless if intact (e.g. an un-cut sheet of wall board).

### FAILURE TO ADHERE TO OUR WARNINGS, SAFETY DATA SHEETS AND INSTALLATION INSTRUCTIONS WHEN WORKING WITH JAMES HARDIE PRODUCTS MAY LEAD TO SERIOUS PERSONAL INJURY OR DEATH.

## AVOID BREATHING IN CRYSTALLINE SILICA DUST!

---

### Safe working practices

- 👎 NEVER use a power saw indoors or in a poorly ventilated area
- 👎 NEVER dry sweep
- 👍 ALWAYS use M Class extractor unit as a minimum and always hose down with water/wet wipe for clean up
- 👎 NEVER use grinders
- 👍 ALWAYS use a circular sawblade specifically designed to minimise dust creation when cutting fibre cement – preferably a sawblade that carries the HardieBlade™ logo or one with at least equivalent performance.
- 👍 ALWAYS follow tool manufacturers' safety recommendations
- 👍 ALWAYS expose only the minimum required depth of blade for the thickness of fibre cement to be cut
- 👍 ALWAYS wear an approved properly-fitted, approved dust mask (P1 or P2) or respirator

Use one of the following methods based on the required cutting rate:

### BEST

- Score and snap knife
- Hand guillotine
- Fibreshear

### BETTER

- Dust reducing circular saw equipped with HardieBlade™ Saw Blade and M Class extractor unit.

### GOOD

- Dust reducing circular saw with HardieBlade™ Saw Blade

### Working outdoors

- 👍 Make sure you work in a well ventilated area
- 👍 Position cutting station so wind will blow dust away from yourself and others in the working area
- 👍 Cut products with either a 'Score or snap' knife or fibre cement shears or, when not feasible, use a HardieBlade™ Saw Blade (or equivalent) and a dust-reducing circular saw attached to a M Class extractor unit
- 👍 When sawing, sanding, rebating, drilling or machining fibre cement products, always:
  - Wear your P1 or P2 mask (correctly fitted in accordance with manufacturers' instructions) and when others are close by, ask them to do the same
  - If you are not clean shaven, then use a powered air respirator with a loose fitting head top.
  - Wear safety glasses
  - Wear hearing protection
  - When others are close by, ask them to do the same.

### Working indoors

- 👎 Never cut using a circular saw indoors
- 👍 Position cutting station in a well ventilated area
- 👍 Cut ONLY using a score and snap knife, hand guillotine or fibreshears (manual, electric or pneumatic)
- 👍 Make sure you clean up BUT never dry sweep. Always hose down with water/wet wipe or use an M Class extractor unit

**IF CONCERN STILL EXISTS ABOUT EXPOSURE LEVELS OR YOU DO NOT COMPLY WITH THE ABOVE PRACTICES, YOU SHOULD ALWAYS CONSULT A QUALIFIED INDUSTRIAL HYGIENIST.**

### Working Instructions

- Refer to Recommended Safe Working Practices before starting any cutting or machining of product.

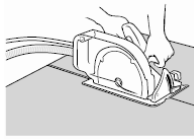

### HardieBlade™ Saw Blade

The HardieBlade™ Saw Blade used with a dust-reducing saw is ideal for fast, clean cutting of James Hardie fibre cement products. A dust-reducing saw uses a dust deflector or a dust collector connected to a vacuum system. When sawing, clamp a straight-edge to the sheet as a guide and run the saw base plate along the straight edge when making the cut.

### Hole-Forming

#### For smooth clean cut circular holes:

- Mark the centre of the hole on the sheet.
- Pre-drill a 'pilot' hole.
- Using the pilot hole as a guide, cut the hole to the appropriate diameter with a hole saw fitted to a heavy duty electric drill.

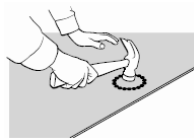

#### For irregular holes:

- Small rectangular or circular holes can be cut by drilling a series of small holes around the perimeter of the hole then tapping out the waste piece from the sheet face.
- Tap carefully to avoid damage to sheets, ensuring that the sheet edges are properly supported.

## STORAGE & DELIVERY

### Keeping products and people safe

#### Off loading

- James Hardie products should be off-loaded carefully by hand or by forklift.
- James Hardie products should not be rolled or dumped off a truck during the delivery to the jobsite.

#### Storage

##### James Hardie products should be stored:

- in their original packaging
- under cover where possible or otherwise protected with a waterproof covering to keep products dry
- off the ground – either on a pallet or adequately supported on timber or other spacers
- flat so as to minimise bending

##### James Hardie products must not be stored:

- directly on the ground
- in the open air exposed to the elements

**JAMES HARDIE IS NOT RESPONSIBLE FOR DAMAGE DUE TO IMPROPER STORAGE AND HANDLING.**

## TIPS FOR SAFE AND EASY HANDLING

### Weatherboard products

- Do not lift planked products flat and in the middle
- Carry the products on the edge
- If only one person is carrying the product, hold it in the middle and spread arms apart to better support the product
- If two people are carrying the plank, hold it near each end and on edge
- Exercise care when handling weatherboard products to avoid damaging the edges/corners

### Sheet products

- Carry with two people
- Hold near each end and on edge
- Exercise care when handling sheet products to avoid damaging the edges/corners





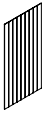
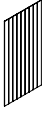
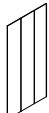





# 13 Product sizes and accessories

Table 7

Axon Panel information					
Product	Description	Thickness	Size		Product Code
			Length	Width	
	<b>Axon Panel 133 Smooth</b> Is a shiplap jointed panel to hide the panel joints. The panel is face primed. The panel has grooves at 133mm centres. The panel must be installed vertically. Nom. Panel Mass: 12.1kg/m <sup>2</sup>	9	2450	1200	403780
			2750	1200	403781
			3000	1200	403782
	<b>Axon Panel 133 Grained</b> Is a shiplap jointed panel to hide the panel joints. The panel is face primed. The panel has grooves at 133mm centres. The panel must be installed vertically. Nom. Panel Mass: 12.1kg/m <sup>2</sup>	9	2450	1200	404510
			2750	1200	404511
			3000	1200	404512
	<b>Axon Panel 400 Smooth</b> Is a shiplap jointed panel to hide the panel joints. The panel is face primed. The panel has grooves at 400mm centres. The panel must be installed vertically. Nom. Panel Mass: 12.1kg/m <sup>2</sup>	9	2450	1200	404414
			2750	1200	404415
			3000	1200	404416

Note: The actual width of the panel is 1203mm. All dimensions and masses provided are approximate only and are subject to manufacturing tolerances.

Table 8









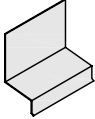
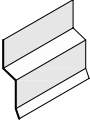

Accessories/tools supplied by James Hardie			
Accessories	Description	Quantity/Size (approx)	Code
	<b>CLD Structural Cavity Batten</b> 19mm thick fibre cement cavity batten installed over RAB Board or a flexible underlay. Axon Panels are fixed to the battens.	19 x 70mm, 2450mm long	<b>403870</b>
	<b>JH 9mm Panel Aluminium External Box Corner</b> A box corner mould to form the external joints. 9mm etch primed.	2450mm long	<b>304509</b>
		2750mm long	<b>304510</b>
		3000mm long	<b>305150</b>
		4000mm long	<b>305808</b>
	<b>JH 9mm Panel Aluminium Horizontal 'h' Mould</b> A horizontal flashing to flash the horizontal joints. 9mm etch primed.	3000mm long	<b>304508</b>
	<b>Aluminium 'h' Mould Jointer</b> A jointer to cover the butt joint of 'h' mould.	100mm long	<b>304512</b>
	<b>uPVC Corner Under Flashing</b> A 50 x 50mm corner under flashing for internal and external joints.	3000mm long	<b>303745</b>
	<b>uPVC Vent Strip</b> Used to provide protection from vermin entering cavity space.	3000mm long	<b>302490</b>
	<b>Annular Threaded Nail</b> 25 x 2.5mm nail.	500gm	<b>300390</b>
	<b>INSEAL® 3259 Tape</b> Black 50mm tape to be used under the vertical shiplap joint. Black 80mm tape to be used at corners.	50m roll	<b>300767</b>
			<b>300769</b>
	<b>CLD Batten Corner Flashing Aluminium</b> Used at internal corner sealant joints at floor joist level.		<b>304652</b>
<b>Tools</b>			
	<b>HardieBlade™ Saw Blade</b> Diamond tip 184mm diameter fibre cement circular saw blade. Spacers not included.	Each	<b>300660</b>

NOTE: uPVC 'h' mould and jointer accessories are also available from James Hardie.

Table 9

## Accessories/tools not supplied by James Hardie

James Hardie recommends the following products for use in conjunction with Axon Panel. James Hardie does not supply these products and does not provide a warranty for their use. Please contact component manufacturer for information on their warranties and further information on their products.

Accessories	Description
	<p><b>Flexible Underlay</b> To comply with Table 23 of E2/AS1.</p>
	<p><b>Flexible Tape</b> A flexible self-adhesive tape used in preparation of a window. Refer to the Window installation section in this manual for more information. e.g. Tyvek®, Protecto or Thermakraft or similar.</p>
	<p><b>Joint Sealant</b> Paintable flexible sealants are recommended for filling the joints. Refer to Section 7.2 for information. e.g. Sika Silaflex MS, Sika AT Façade, Bostik Seal N Flex-1 or similar</p>
	<p><b>Head Flashing</b> Required over window heads to be supplied by window installer. Material must comply with Table 20 and 21 of E2/AS1.</p>
	<p><b>Flashing Material</b> as per Table 20, 'E2/AS1'</p>
	<p><b>HardieFlex™ Hot Dip Galv and Stainless Steel 316 nails</b> For fixing panels direct to framing. 40 x 2.8mm</p>
	<p><b>C-25 Stainless Steel Brad Nails</b> 304SS brad nails used to install Axon Panels to the CLD Structural Cavity Battens used in a straight bradder. Paslode: (09) 477 3000</p>
	<p><b>ND 50 Stainless Steel Brad Nails</b> Used to install Axon Panel direct fix to timber framing. Used in a straight bradder.</p>
	<p><b>65 x 2.87mm RoundDrive Ring Shank Nail</b> For fixing CLD Structural Cavity Battens to the framing. Paslode: (09) 477 3000</p>
	<p><b>Bostik Seal N Flex-1</b> 'Seal N Flex-1' Polyurethane adhesive sealant manufactured by BOSTIK for applying between the panels and battens, Refer to section 5 for more information. BOSTIK: ALK: (09) 579 6253, WGTN: (04) 567 5119, CHCH: (03) 366 2583.</p>
	<p><b>Sika Sikaflex 11FC</b> Sika: 0800 SIKA NZ (0800 745 269)</p>
	<p><b>200mm wide Polypropylene DPC</b> Product used over flexible underlay at external and internal corners. ie. Super Course 500</p>

# 14 Details

The following generic details have been provided in this document for both direct fixed and cavity construction methods.

Table 10

Details				
Description	Direct Fixed		CLD Structural Cavity Batten Construction	
	Figure No.	Page No.	Figure No.	Page No.
Typical framing setout	Figure 1	16	Figure 15	25
Typical panel nail fixing setout	Figure 2	17	Figure 17	27
	Figure 13	24		
Foundation detail	Figure 3	18	Figure 18	28
Vertical shiplap joint	Figure 4	18	Figure 19	29
	Figure 14	25		
Soffit detail	Figure 5	19	Figure 32	39
Internal corner detail	Figure 6	19	Figure 21	30
External corner detail	Figure 7	20	Figure 22	31
Section at sill	Figure 8	20	Figure 24	33
Window jamb	Figure 9	21	Figure 25	34
Window head	Figure 10	21	Figure 26	34
Window head with facings			Figure 27	35
Window jamb with facings			Figure 28	35
Window sill with planted sill			Figure 29	36
Horizontal joint detail	Figure 11	22	Figure 30	37
			Figure 31	38
Corner at 'h' mould joint detail	Figure 12	23		
Batten fixing setout			Figure 16	26
Intermediate stud fixing			Figure 20	30
Jointing of CLD Structural Cavity Batten			Figure 23	32
External corner			Figure 33	40
Cavity pipe penetration			Figure 34	40
Internal corner			Figure 35	41
Aluminium 'h' mould joiner			Figure 36	42
One piece apron flashing joint			Figure 37	43
Drained flashing joint at floor joist			Figure 38	44
Meter box at sill			Figure 39	45
Meter box at jamb			Figure 40	45
Meter box at head			Figure 41	46
Garage door jamb			Figure 42	47
Garage door head			Figure 43	48
Junction between Axon Panel and fascia board			Figure 44	49
Enclosed roof to wall intersection			Figure 45	50

Figure 1: Direct fixed typical framing setout

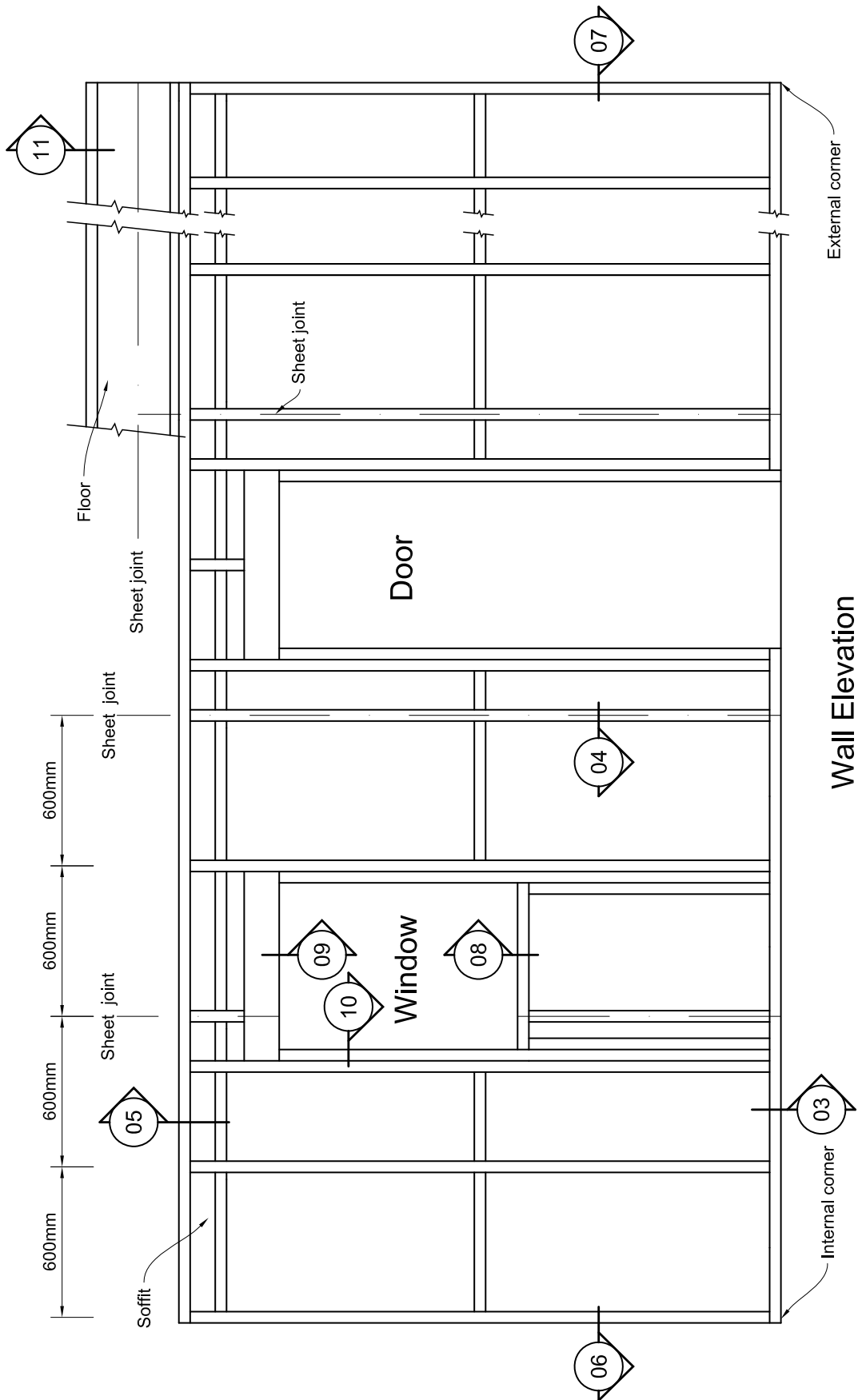
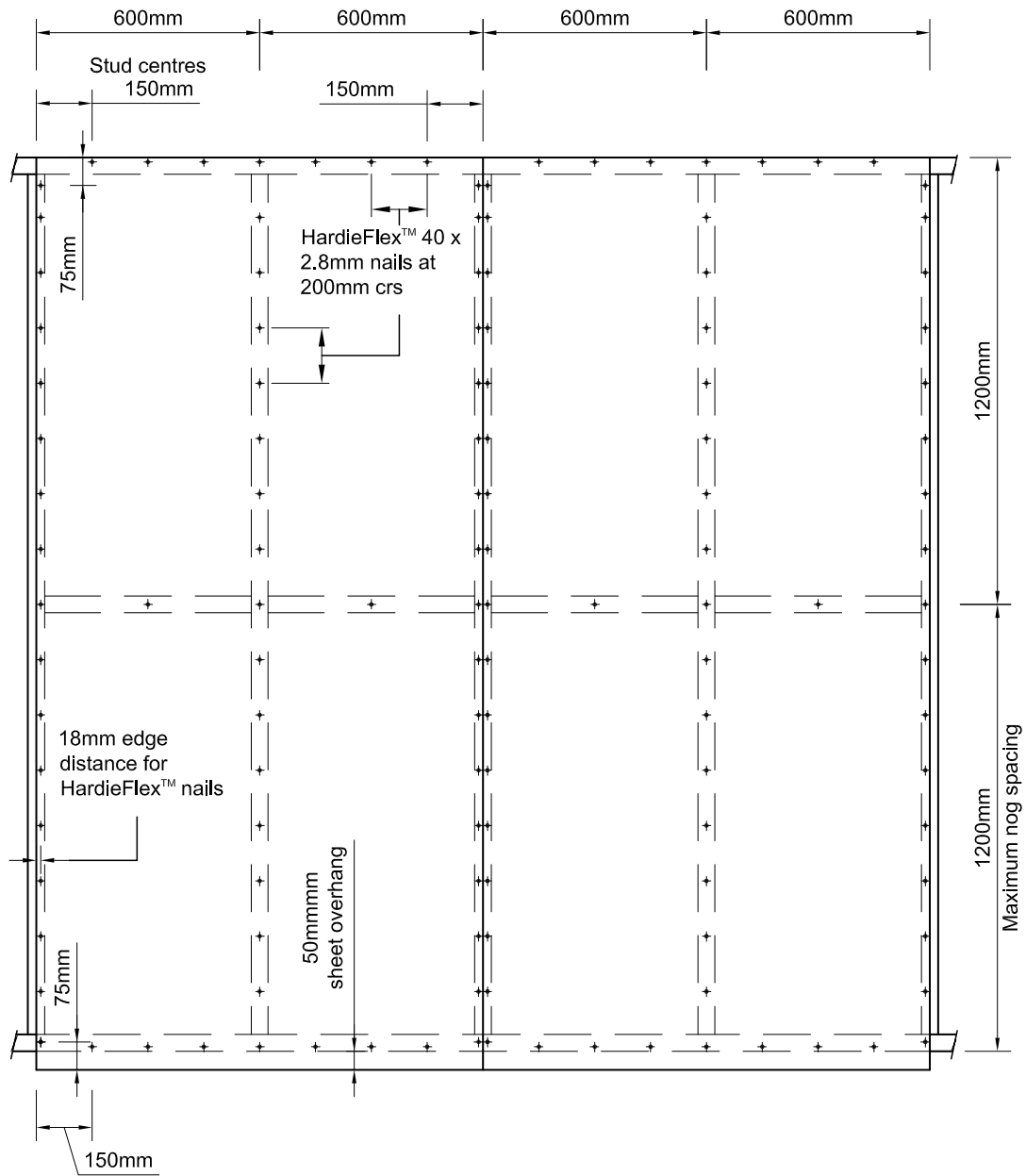

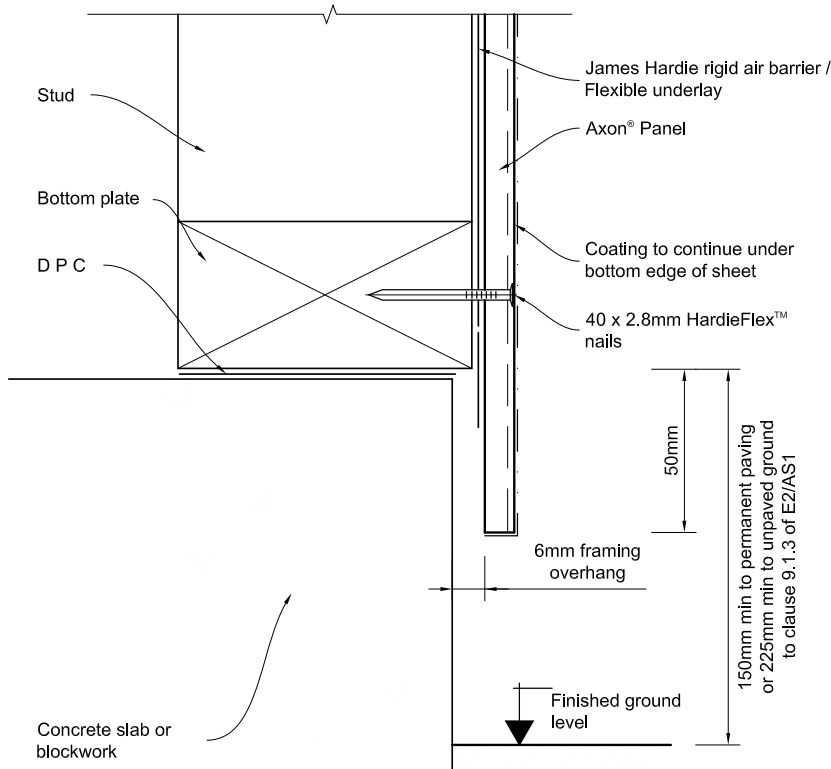

Figure 2: Direct fixed typical panel HardieFlex nail fixing setout



Note: When studs spaced at 400mm centres using Axon® Panel 400, the nail fixings to intermediate studs to be offset 5mm from the groove in Panel.

Figure 3: Direct fixed foundation detail



Note: Refer to Section 2.4 for further information

Figure 4: Vertical shiplap joint — HardieFlex nail

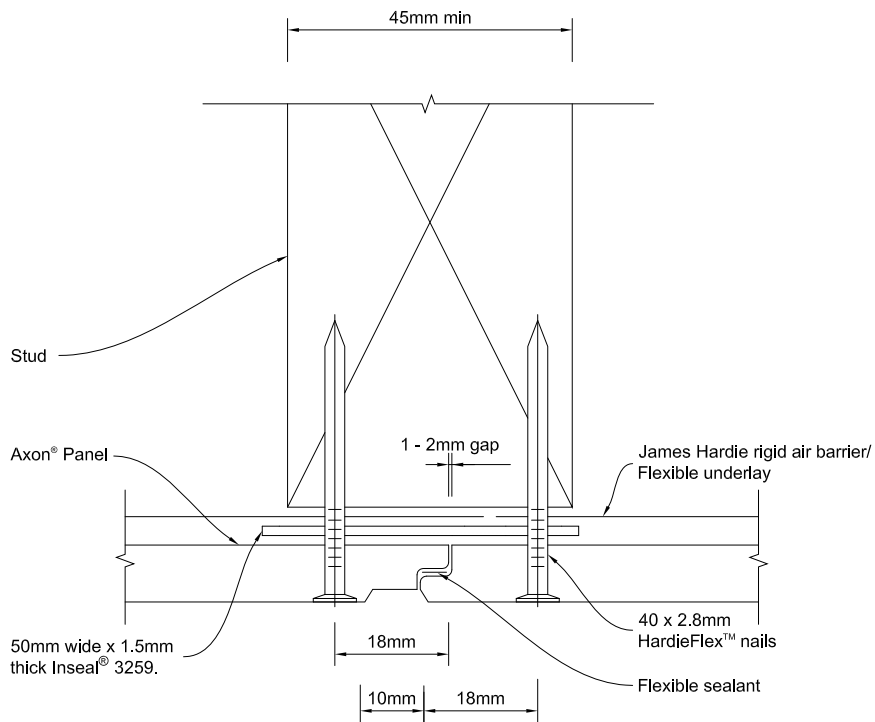

Figure 5: Soffit detail

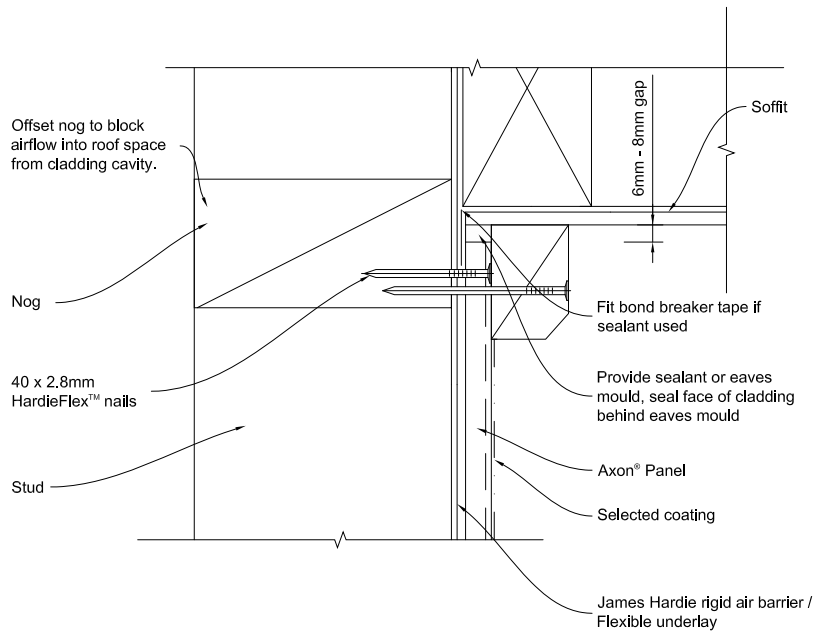

Figure 6: Internal corner detail

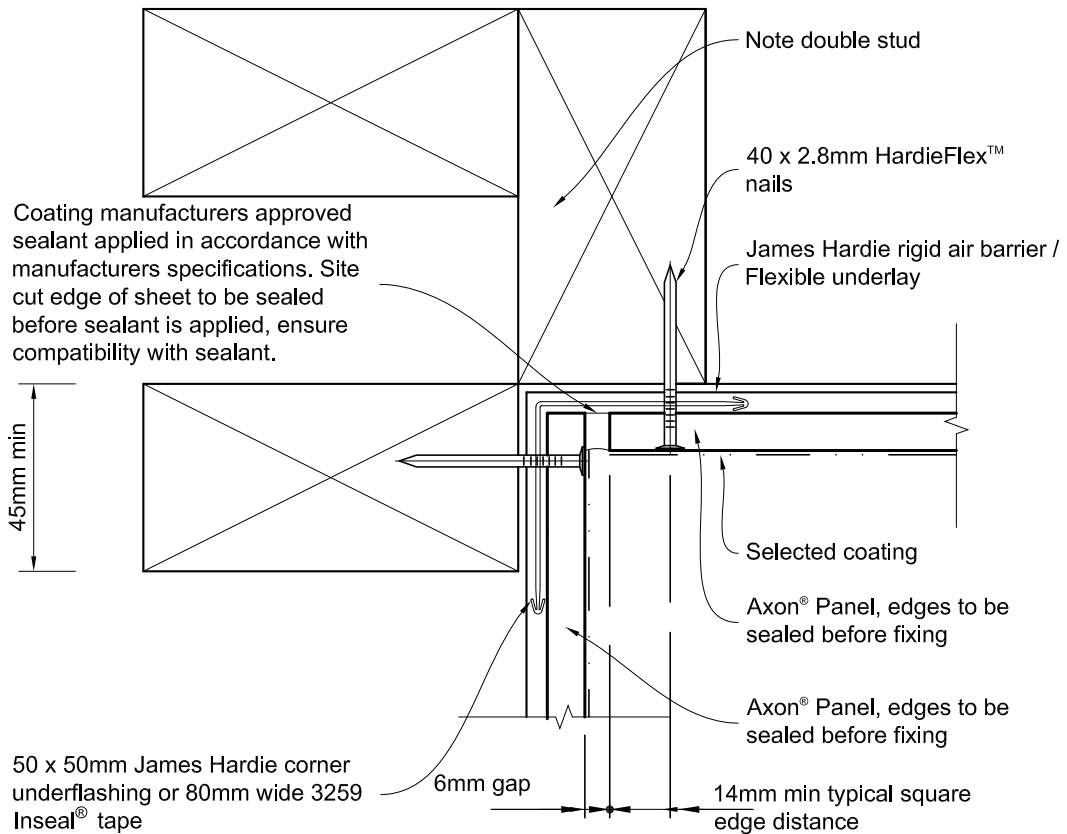

Figure 7: External corner detail

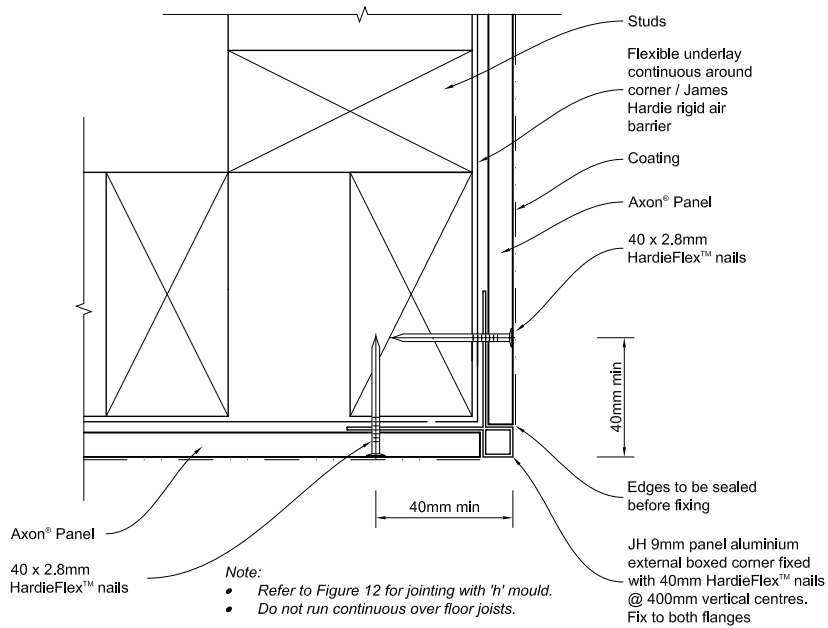
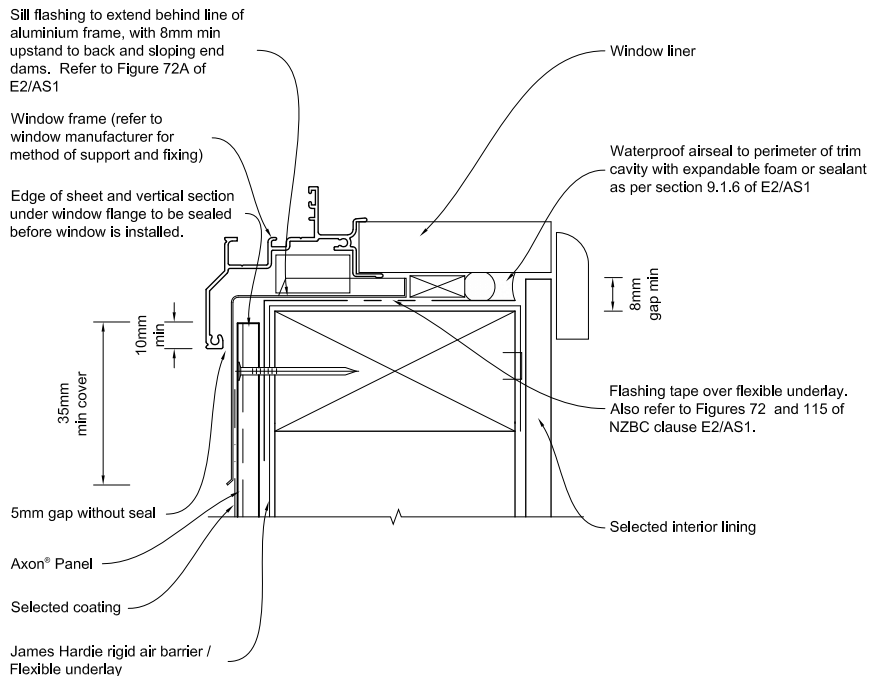

Figure 8: Section at sill



**General notes for materials selection**

- Flashing materials must be selected based on environmental exposure, refer to NZS 3604 and Table 20 of NZBC E2/AS1.
- Flexible underlay must comply with acceptable solution E2/AS1.
- Flashing tape must have proven compatibility with the selected flexible underlay and other materials with which it comes into contact.

Refer to the manufacturer or supplier for technical information for these materials.

Figure 9: Window jamb

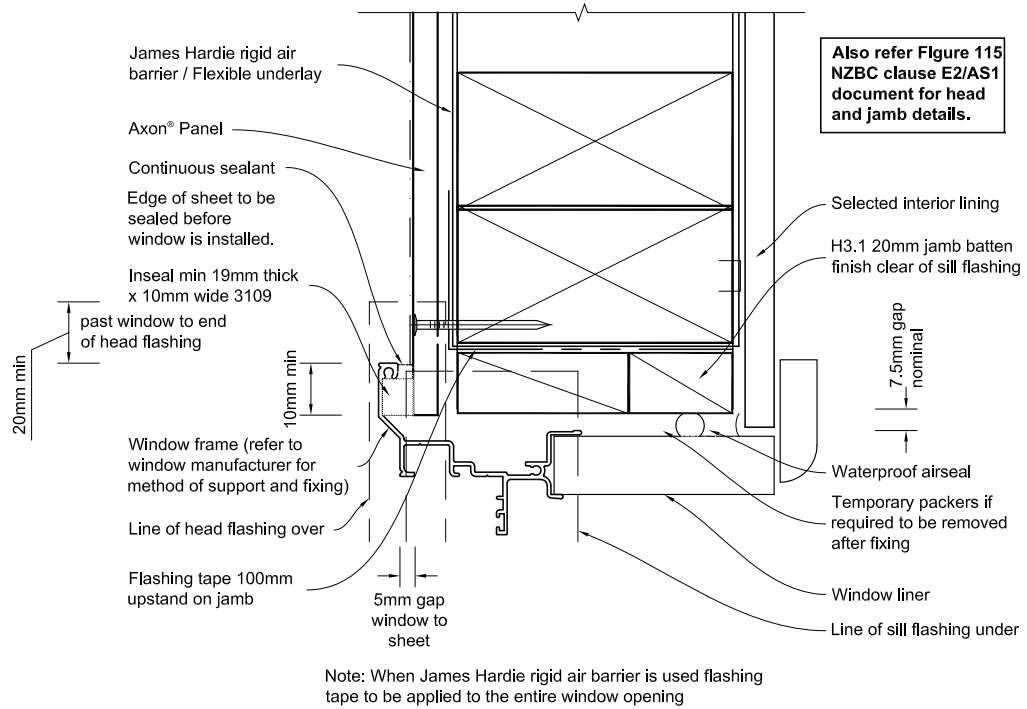

Figure 10: Window head

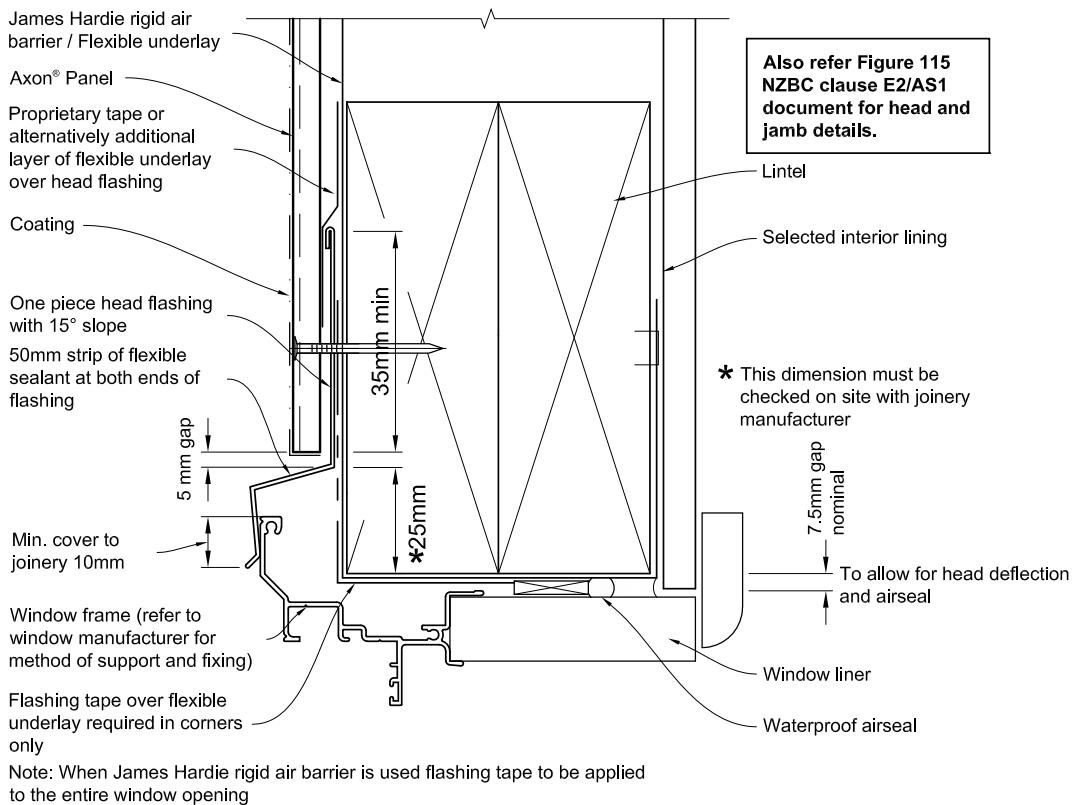
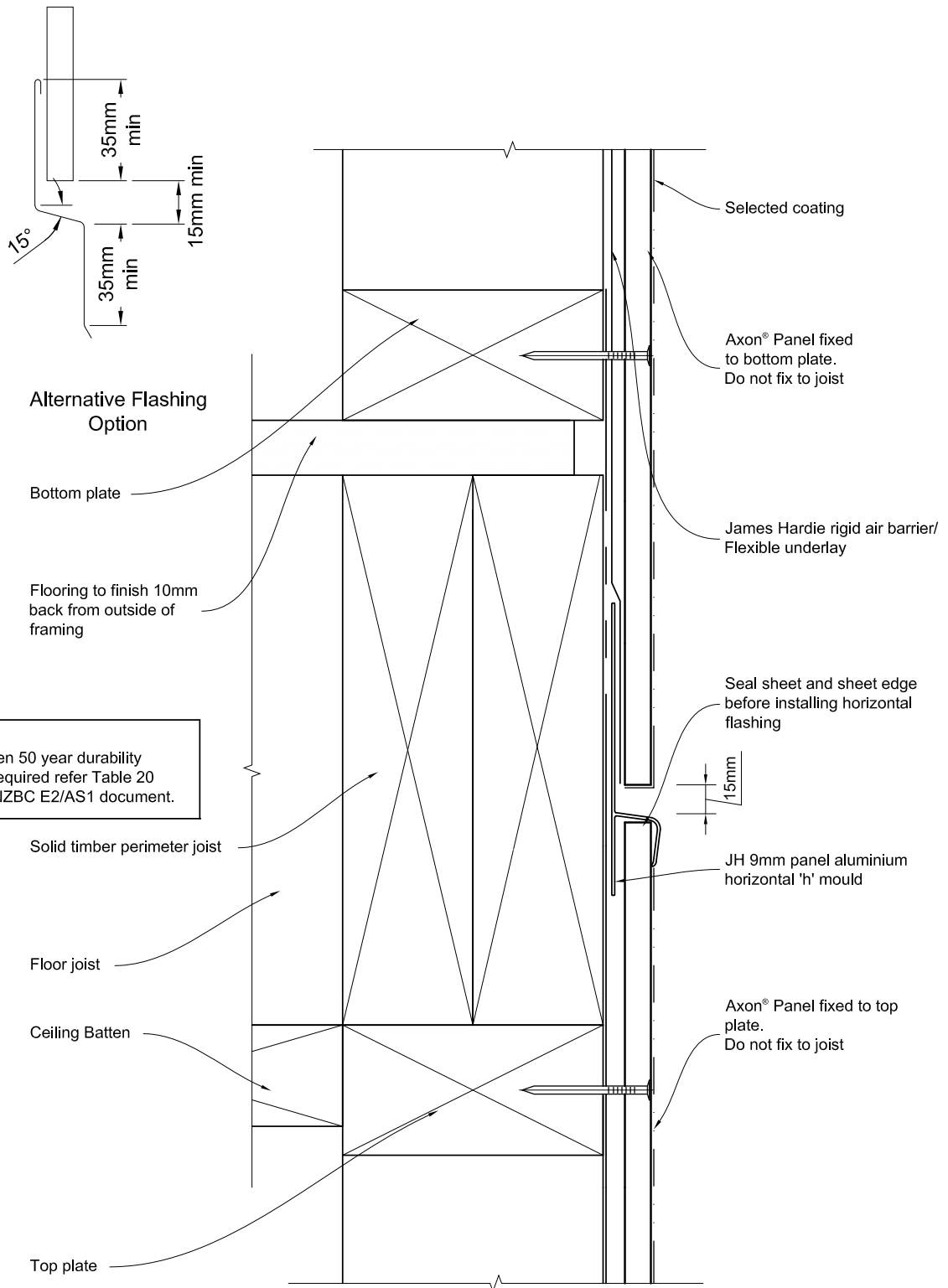

Figure 11: Horizontal joint detail



**Note:**  
 1. When 50 year durability is required refer Table 20 of NZBC E2/AS1 document.

Figure 12: Corner at 'h' mould joint detail

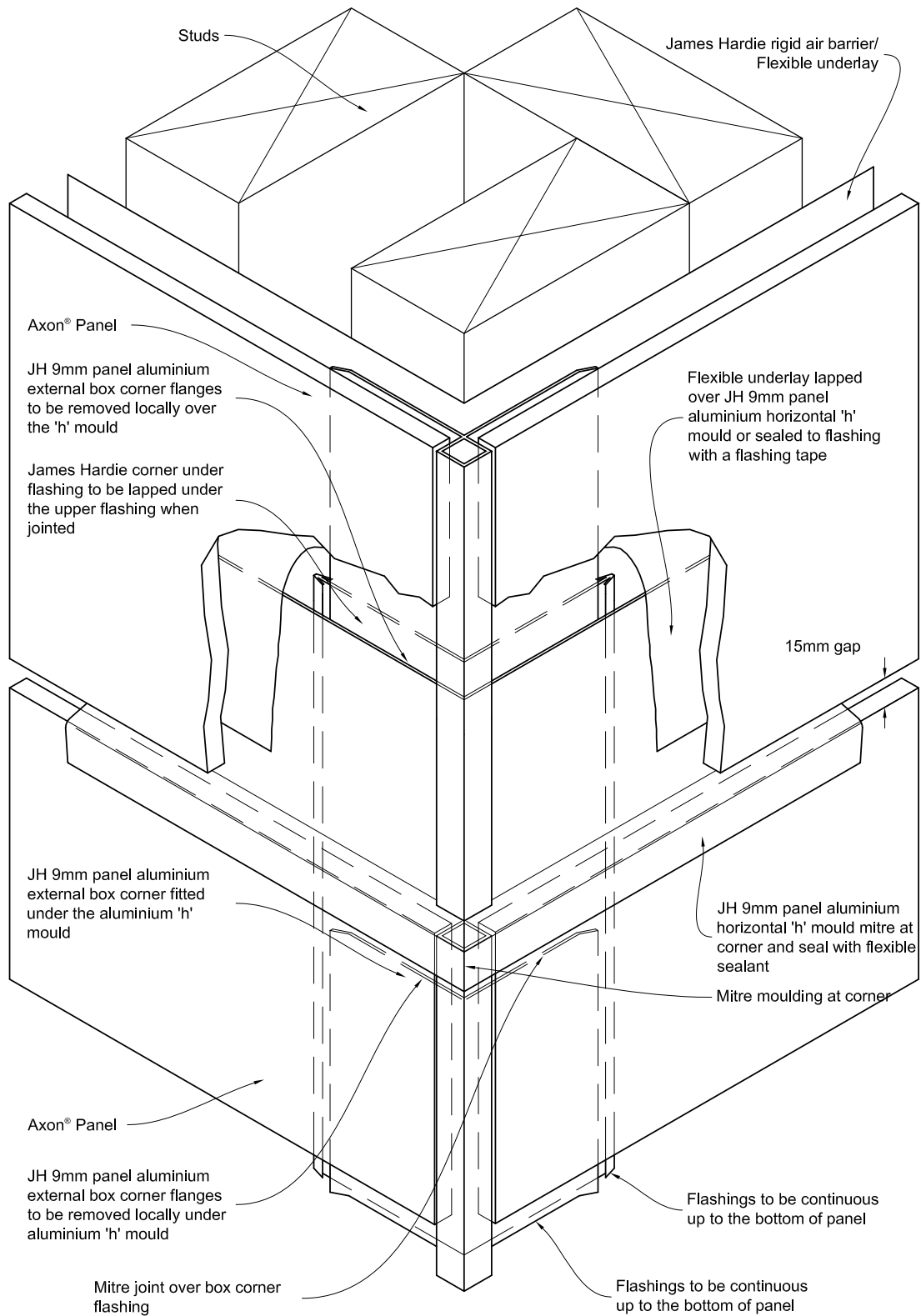

Figure 13: Direct fixed typical panel brad nail fixing setout

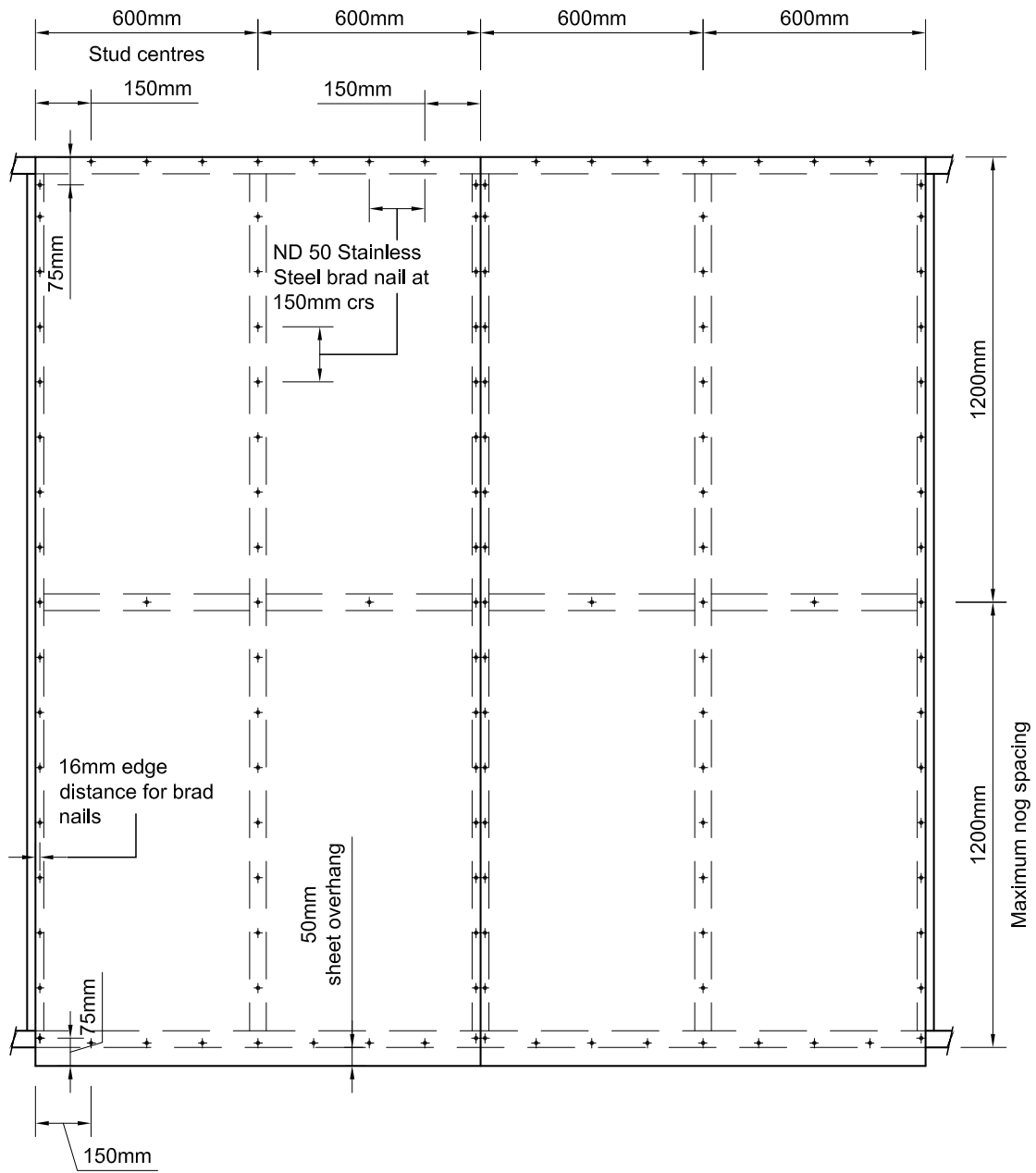



Figure 14: Shiplap joint — brad nail

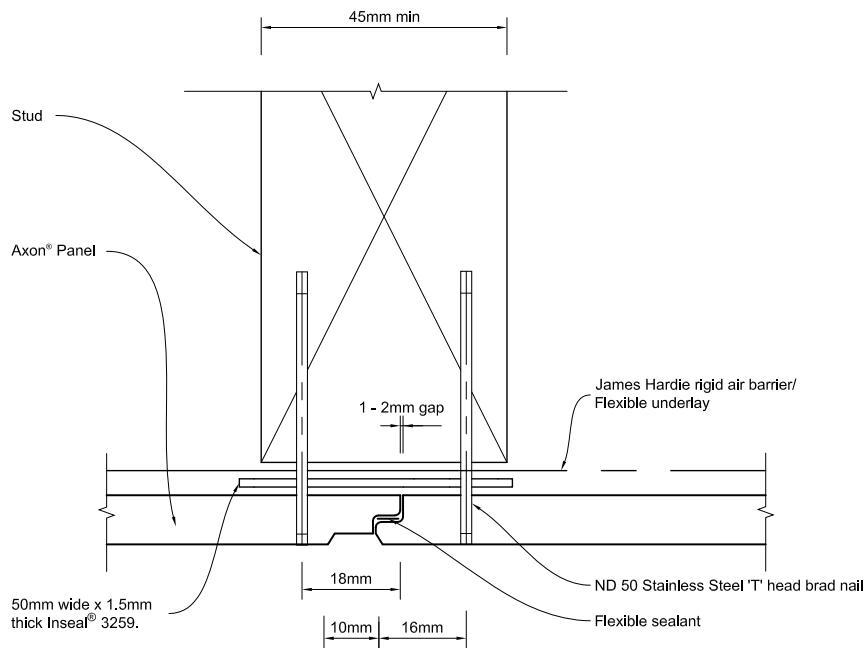

Figure 15: Framing setout

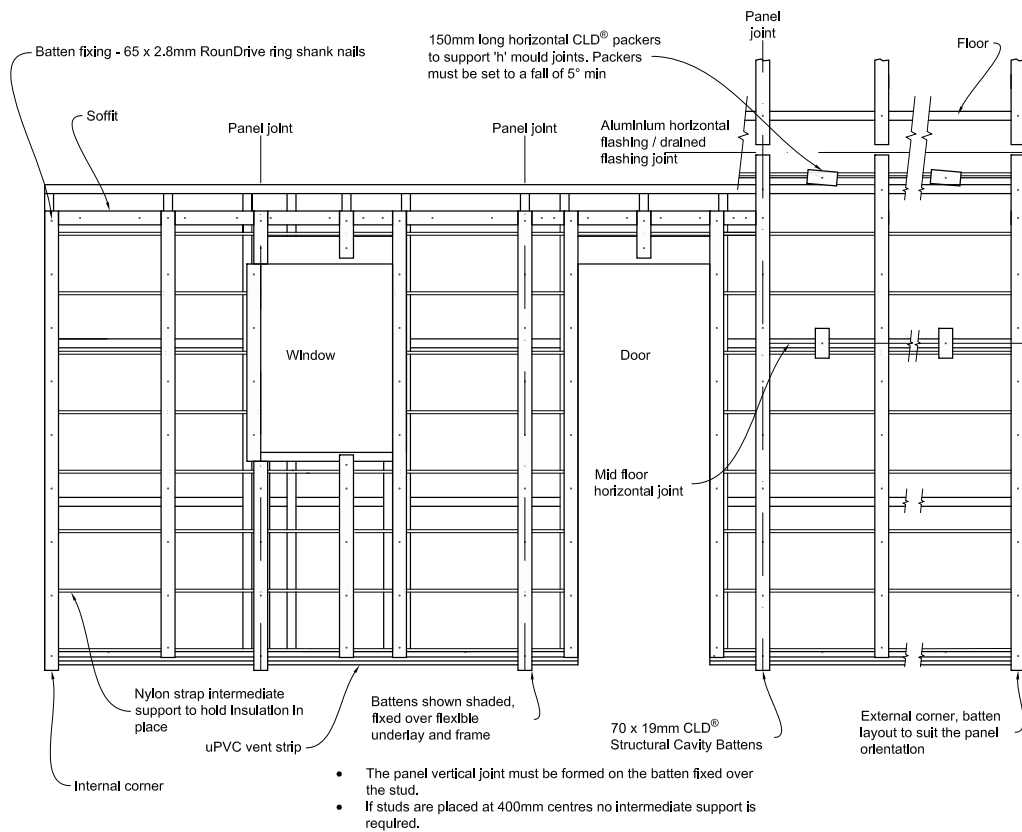

Figure 16: Batten fixing setout

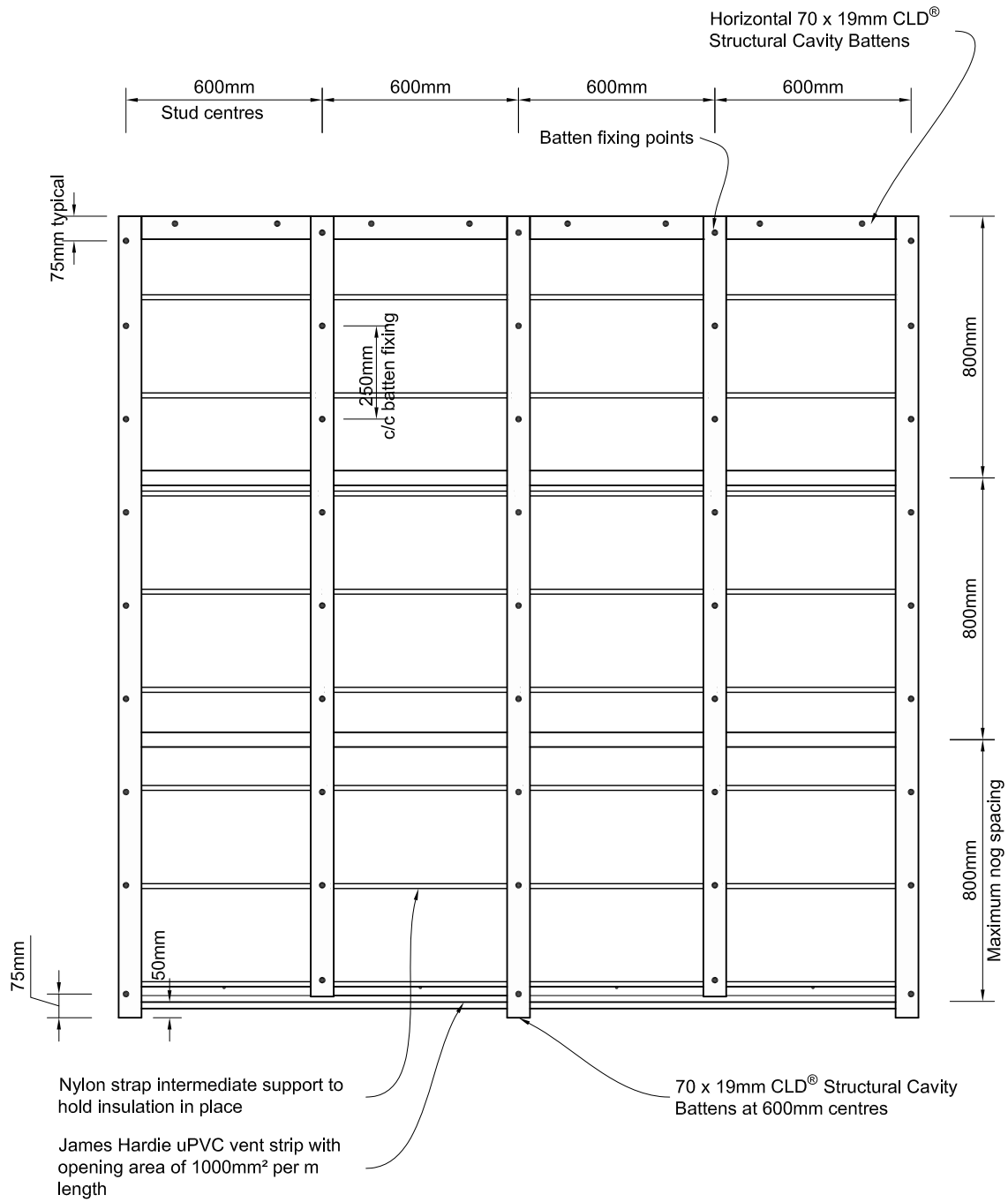
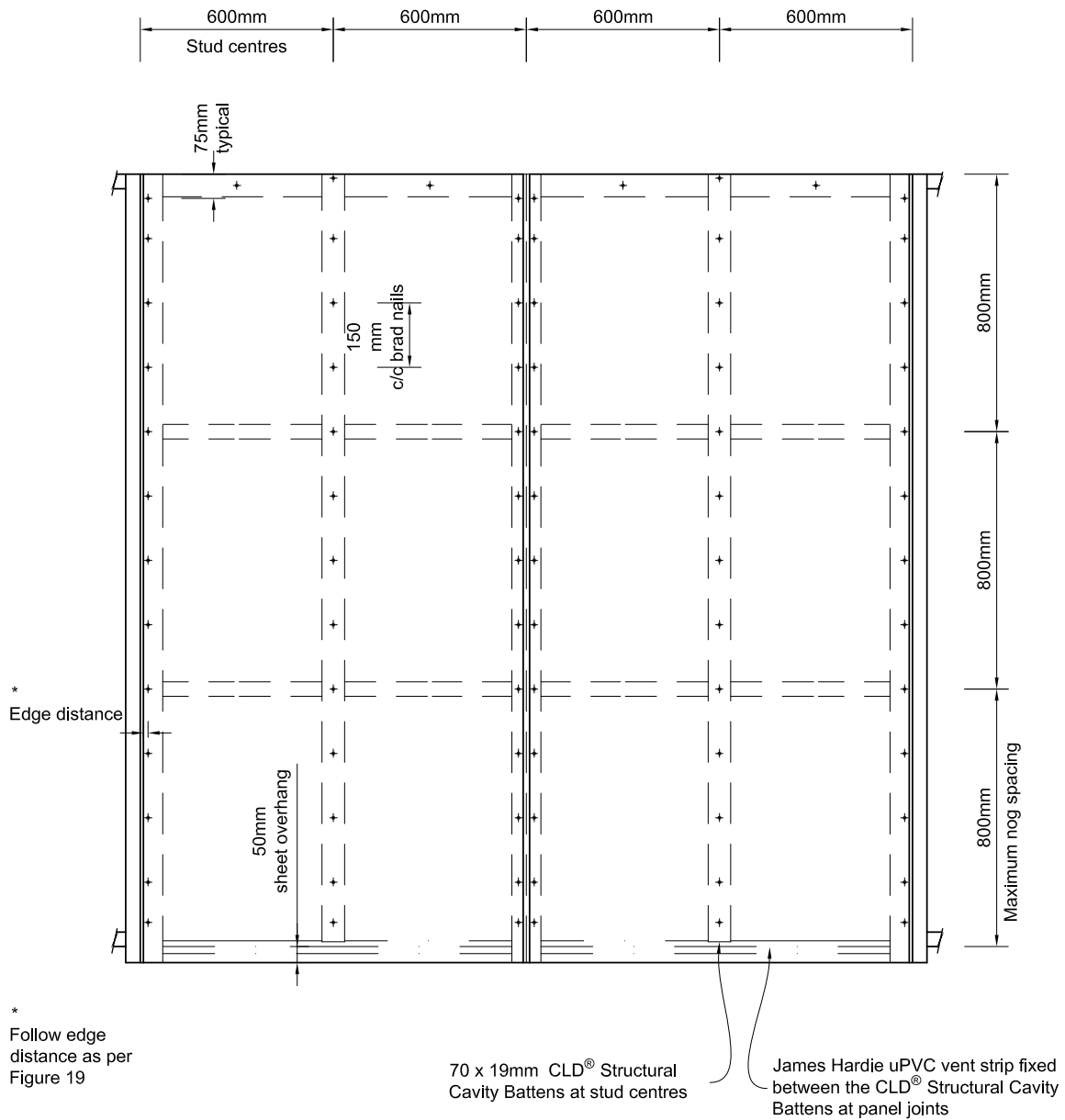
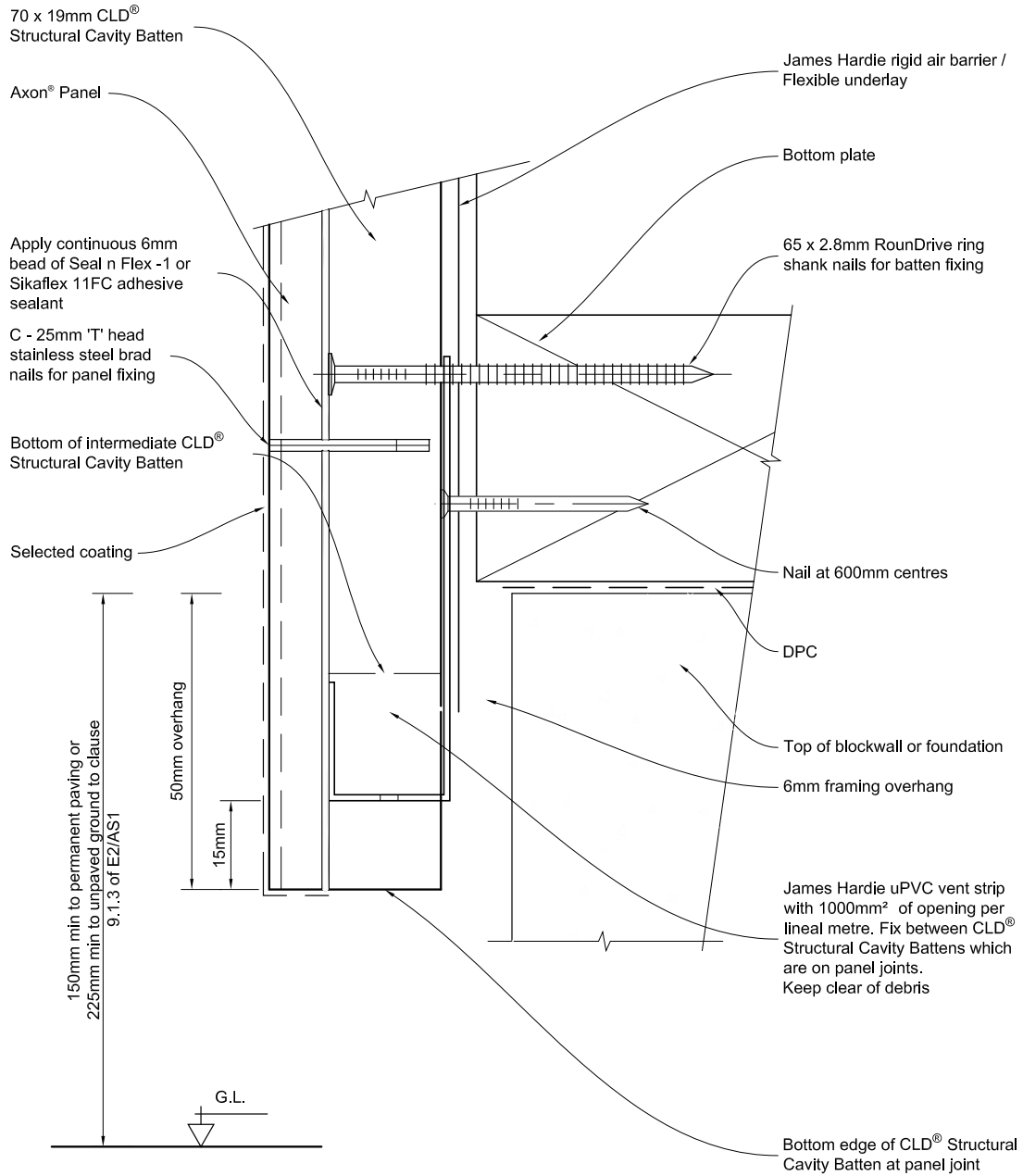

Figure 17: Sheet fixing setout



Note: When studs spaced at 400mm centres using Axon<sup>®</sup> Panel 400, the nail fixings to intermediate studs to be offset 5mm from the groove in Panel.

Figure 18: Foundation detail



**Notes:**

- Check panel extends past bottom plate as specified in Architects specification (50mm min).
- uPVC Vent strip must remain level and secure during construction. Cut and fix uPVC vent strip between CLD<sup>®</sup> Structural Cavity Battens fixed under the panel joints.
- Check vent strip is free from site debris.

Figure 19: Vertical shiplap joint

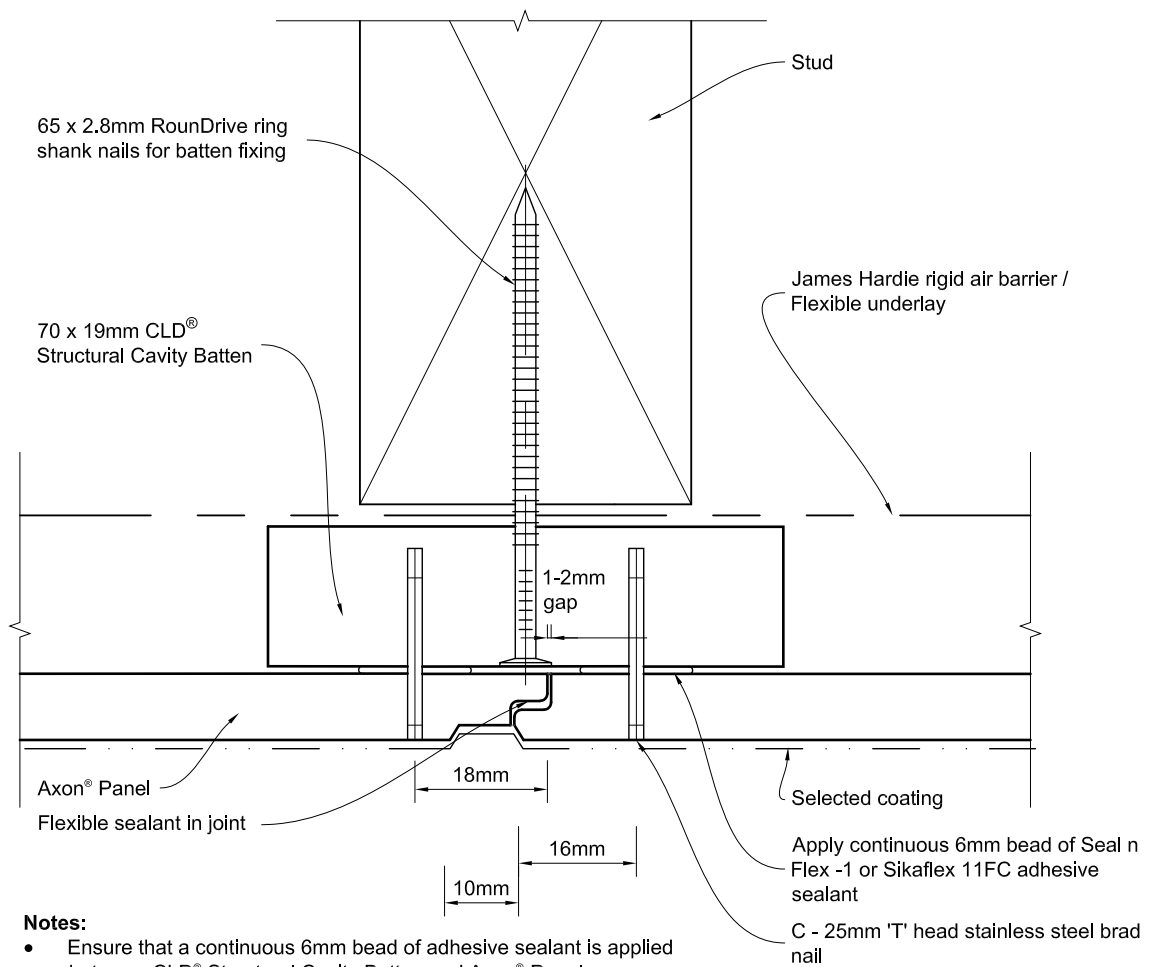

**Notes:**

- Ensure that a continuous 6mm bead of adhesive sealant is applied between CLD<sup>®</sup> Structural Cavity Batten and Axon<sup>®</sup> Panel.
- Ensure that the required edge distance is maintained when fixing.
- Seal cut edges with a primer compatible with final coatings.

Figure 20: Intermediate stud fixing

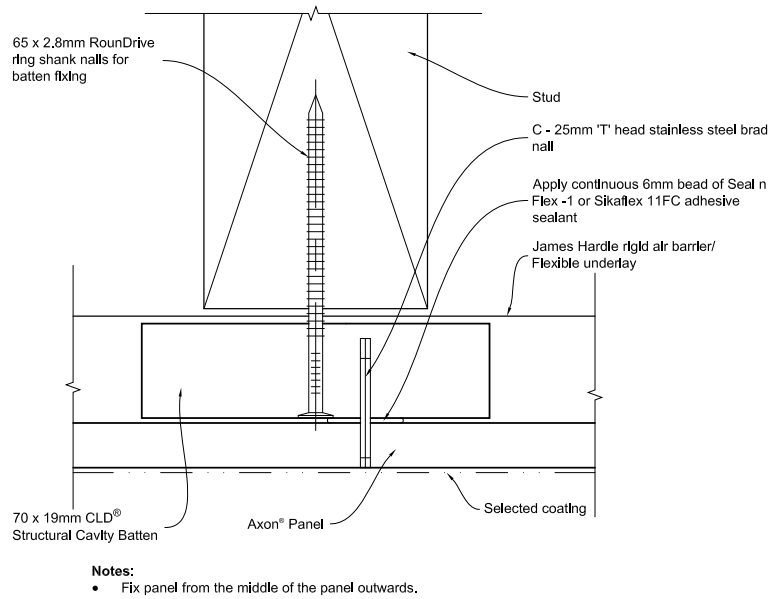

Figure 21: Internal corner

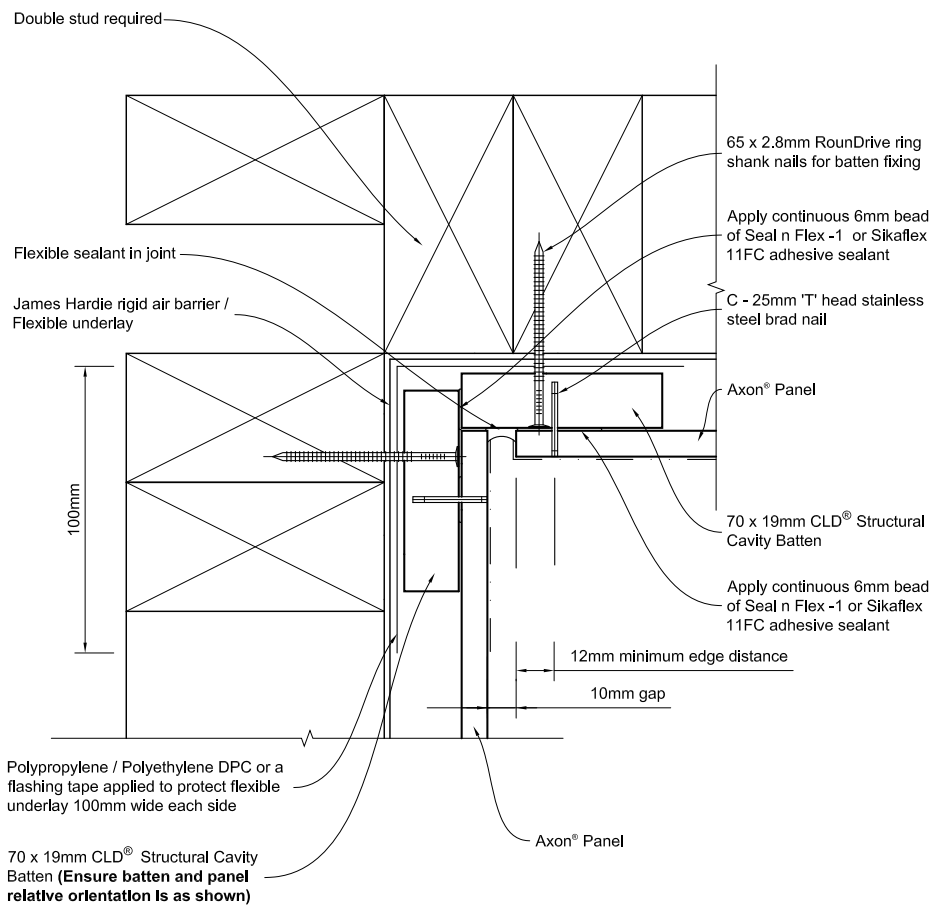

Figure 22: External corner

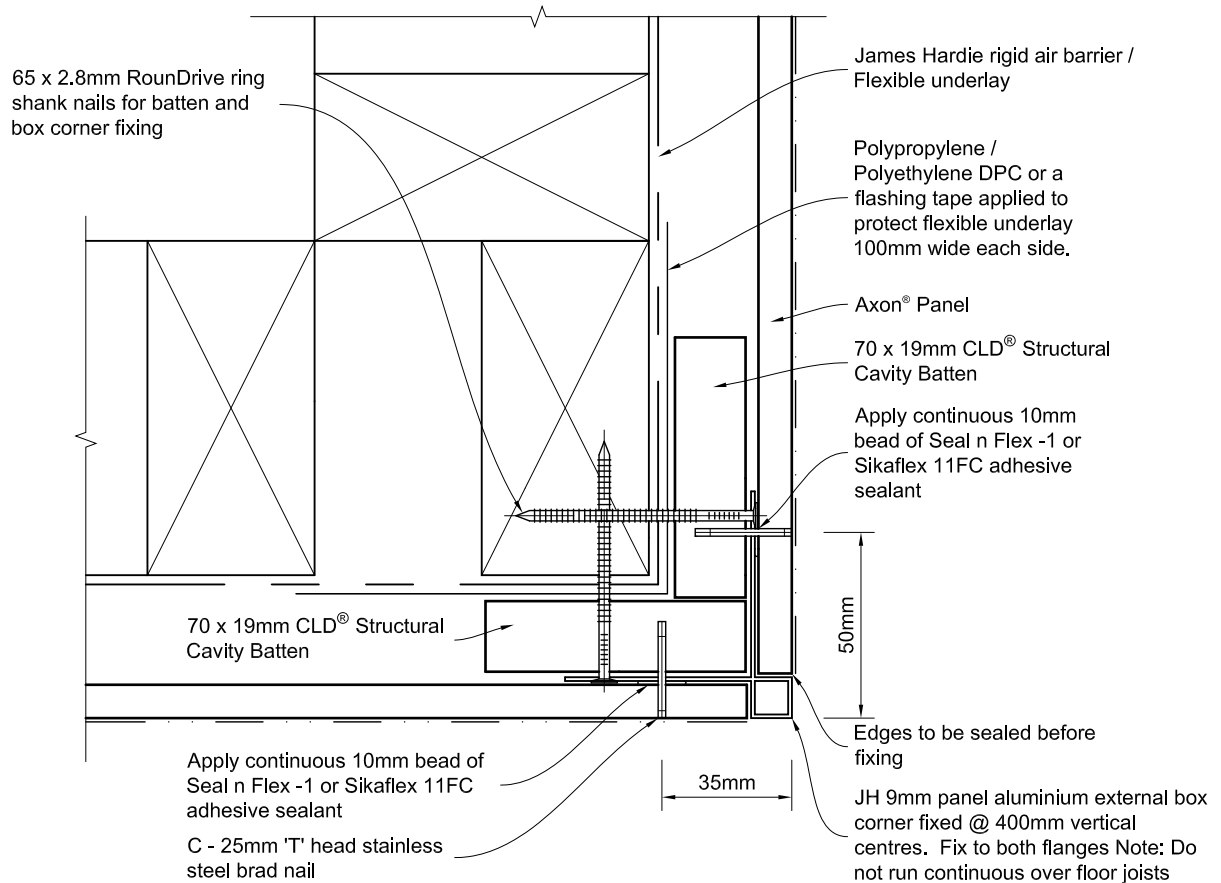

Figure 23: Jointing of CLD Structural Cavity Batten

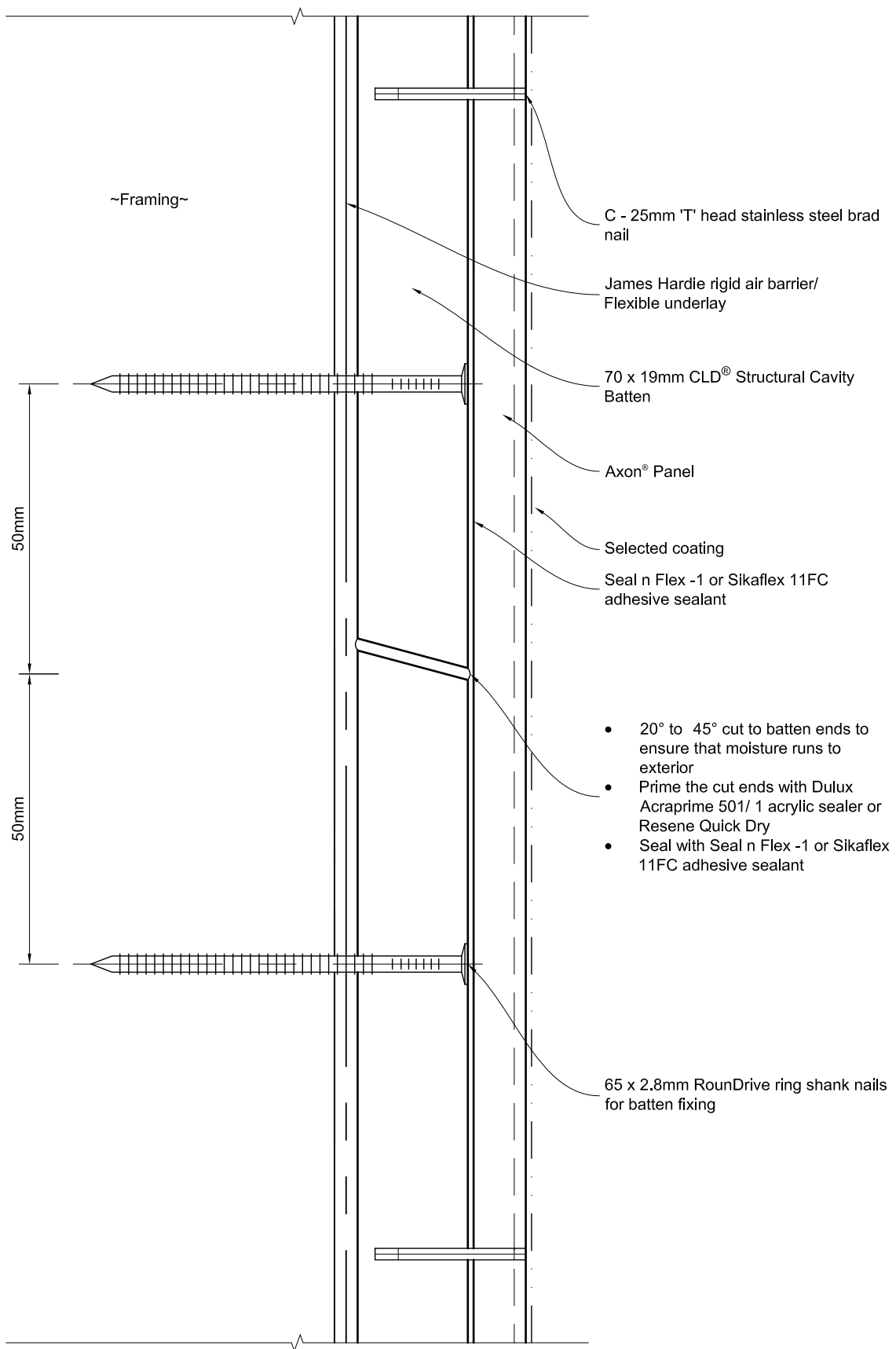
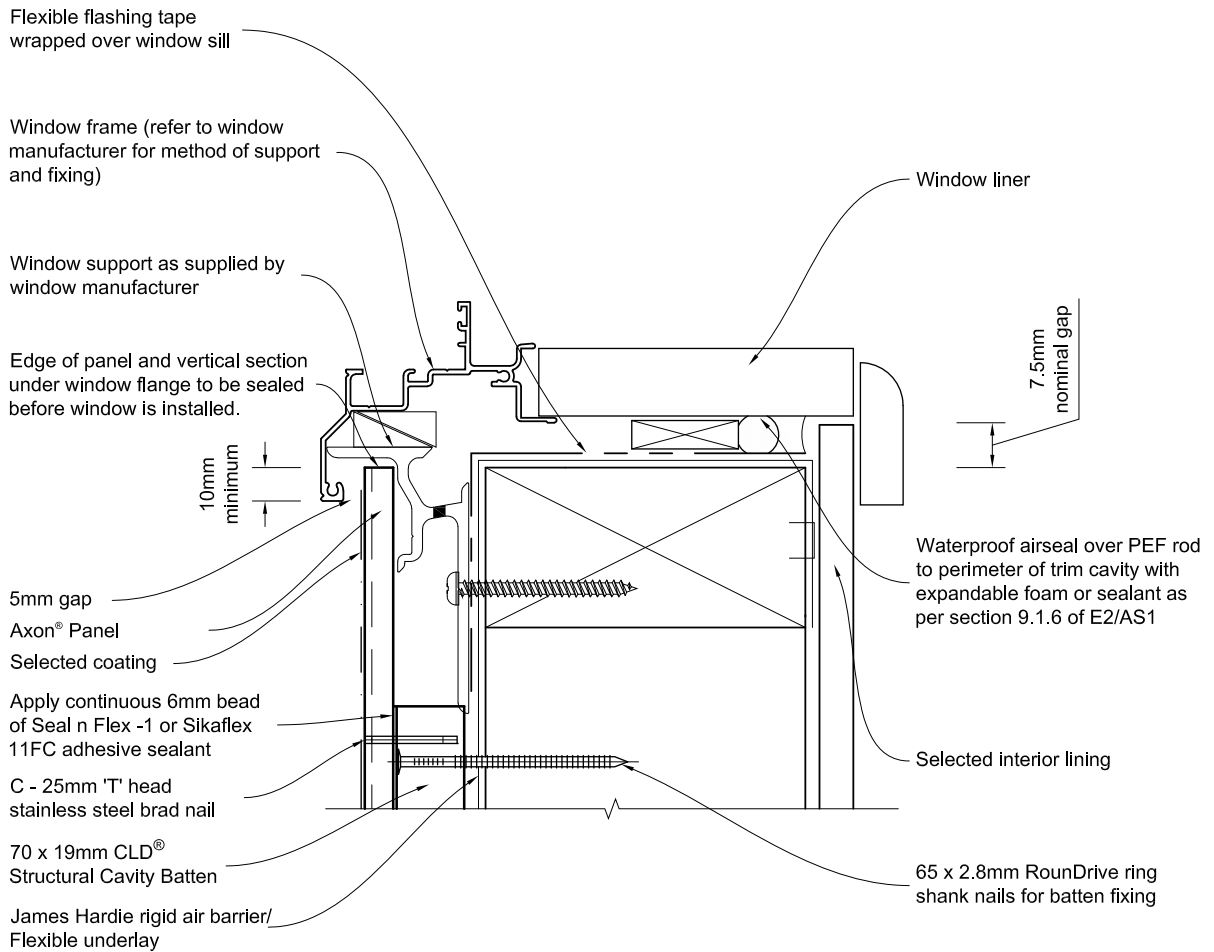



Figure 24: Window sill



**General notes for materials selection**

1. Flashing materials must be selected based on environmental exposure, refer to NZS 3604 and Table 20 of NZBC E2/AS1.
2. Flexible underlay must comply with acceptable solution E2/AS.
3. Flashing tape must have proven compatibility with the selected flexible underlay and other materials with which it comes into contact.

*Refer to the manufacturer or supplier for technical information for these materials.*

Figure 25: Window jamb

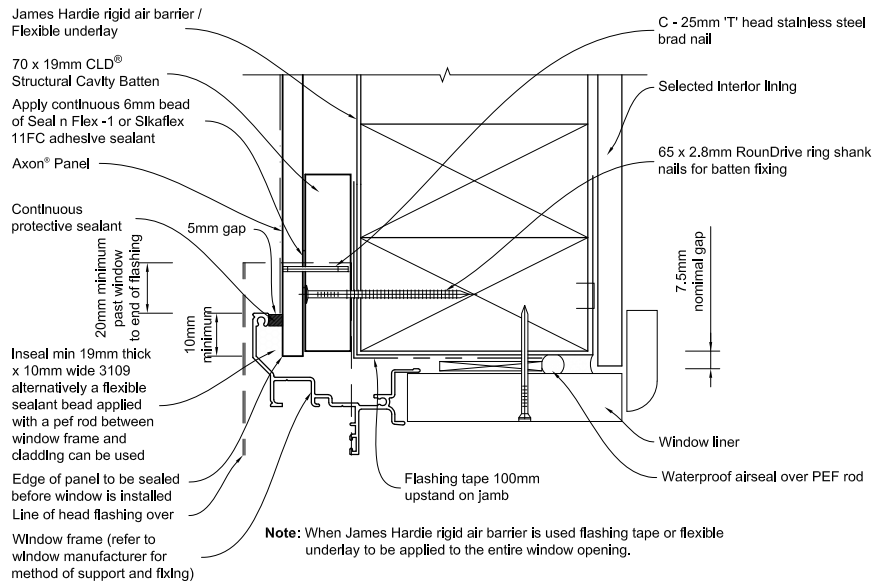

Figure 26: Window head

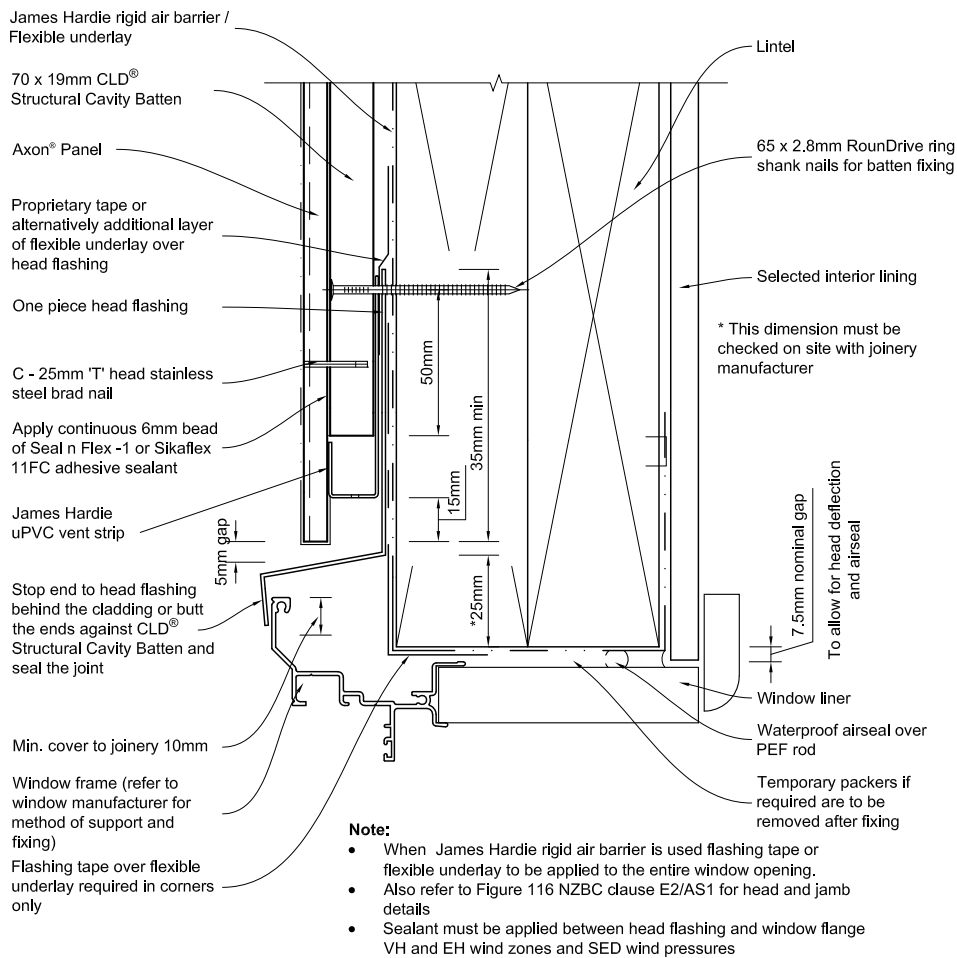

Figure 27: Window head with facings

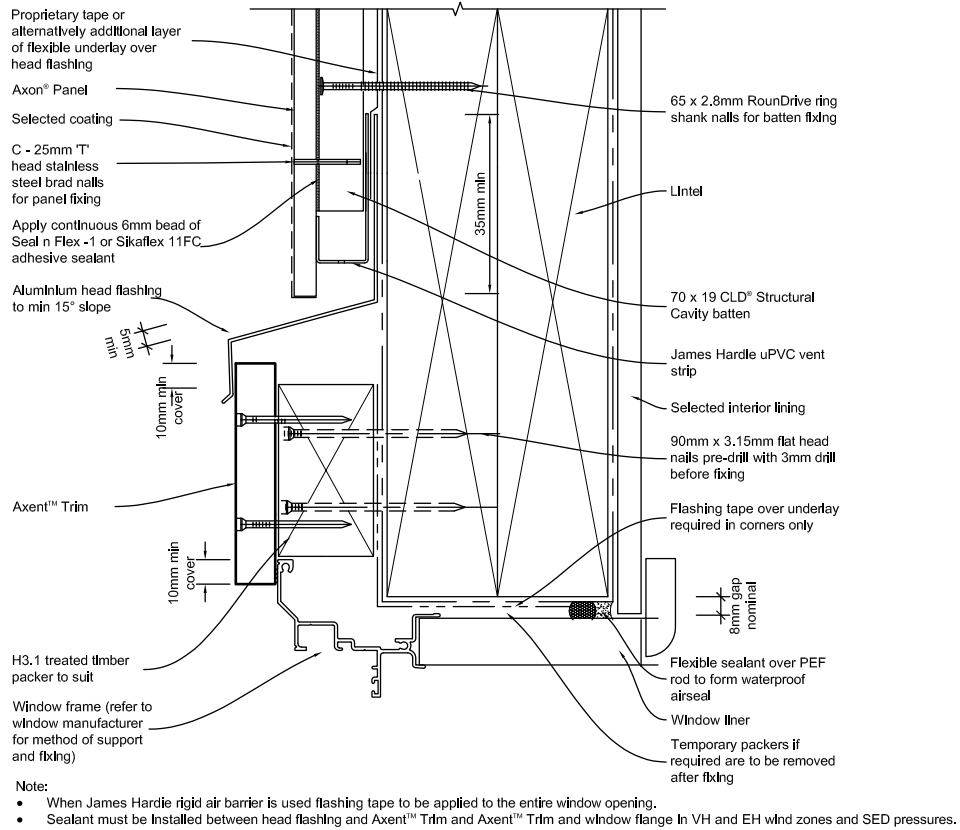

Figure 28: Window jamb with facings

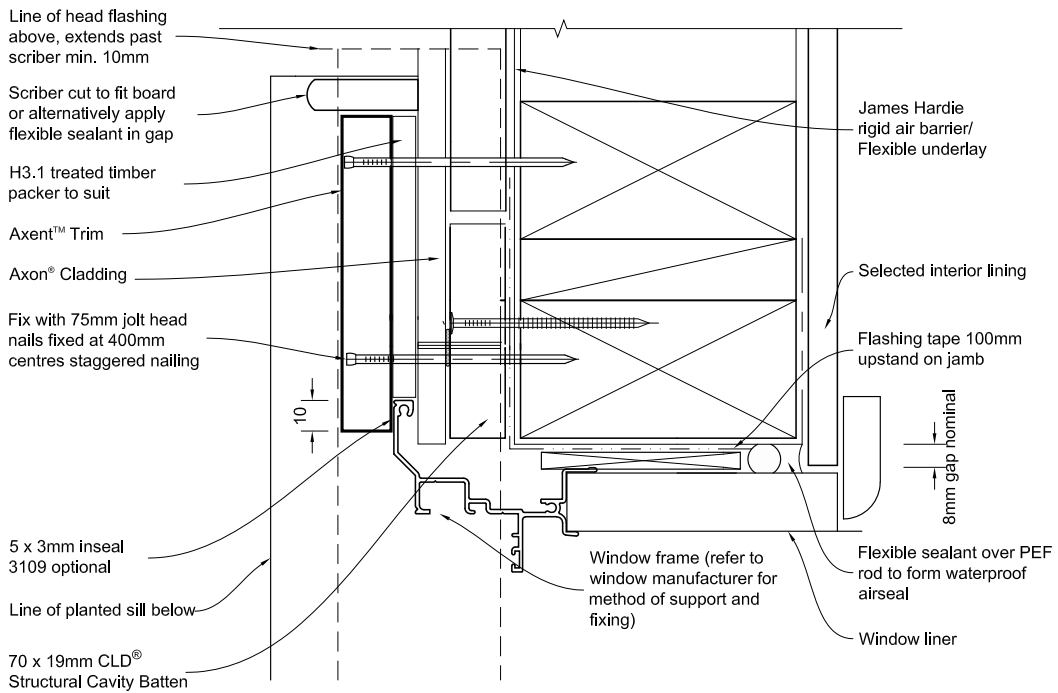
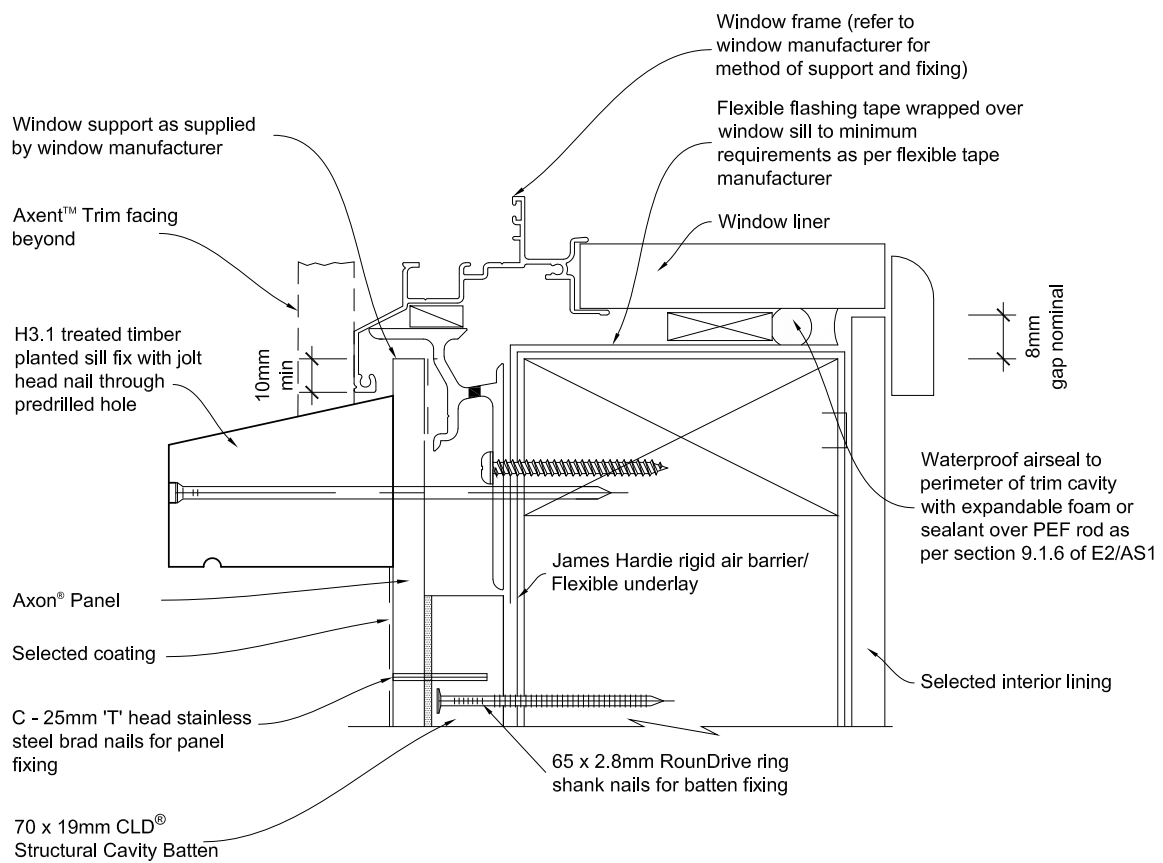

Figure 29: Window sill with planted sill



General notes for materials selection

1. Flashing materials must be selected based on environmental exposure, refer to NZS 3604 and Table 20 of NZBC E2/AS1.
2. Flexible underlay must comply with acceptable solution E2/AS1.
3. Flashing tape must have proven compatibility with the selected flexible underlay and other materials with which it comes into contact.
4. When James Hardie rigid air barriers are used flashing tape to be applied to the entire opening.

Refer to the manufacturer or supplier for technical information for these materials.

Figure 30: Horizontal joint at floor joist

Seal n Flex -1 or Sikaflex 11FC adhesive sealant between panel and batten omitted for clarity

James Hardie rigid air barrier / Flexible underlay

70 x 19mm CLD<sup>®</sup> Structural Cavity Batten

Axon<sup>®</sup> Panel

JH 9mm panel aluminium horizontal 'h' mould.

Seal sheet and sheet edge before installing horizontal flashing

C - 25mm 'T' head stainless steel brad nail

150mm long horizontal CLD<sup>®</sup> packers optional between vertical battens when battens are fixed over studs at 600mm apart. Packers must be set to a fall of 5° min

~Bottom plate~

~Solid timber perimeter joists~

~Floor joist~

~Top plate~

~Ceiling batten~

65 x 2.8mm RoundDrive ring shank nails for batten fixing

Selected coating

### Alternative Flashing Option

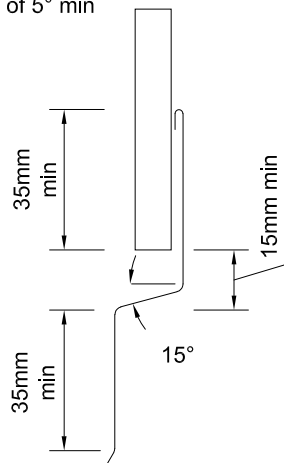

**Note:**

1. When 50 year durability is required refer Table 20 of NZBC E2/AS1 document.

Figure 31: Horizontal joint in tall wall

Seal n Flex -1 or Sikaflex 11FC adhesive sealant between panel and batten omitted for clarity

James Hardie rigid air barrier / Flexible underlay

70 x 19mm CLD<sup>®</sup> Structural Cavity Batten

Axon<sup>®</sup> Panel

JH 9mm panel aluminium horizontal 'h' mould.

Seal sheet and sheet edge before installing horizontal flashing

10mm gap

C - 25mm 'T' head stainless steel brad nail

150mm long vertical CLD<sup>®</sup> packers optional between vertical battens when battens are fixed over studs at 600mm apart.

65 x 2.8mm RoundDrive ring shank nails for batten fixing

Selected coating

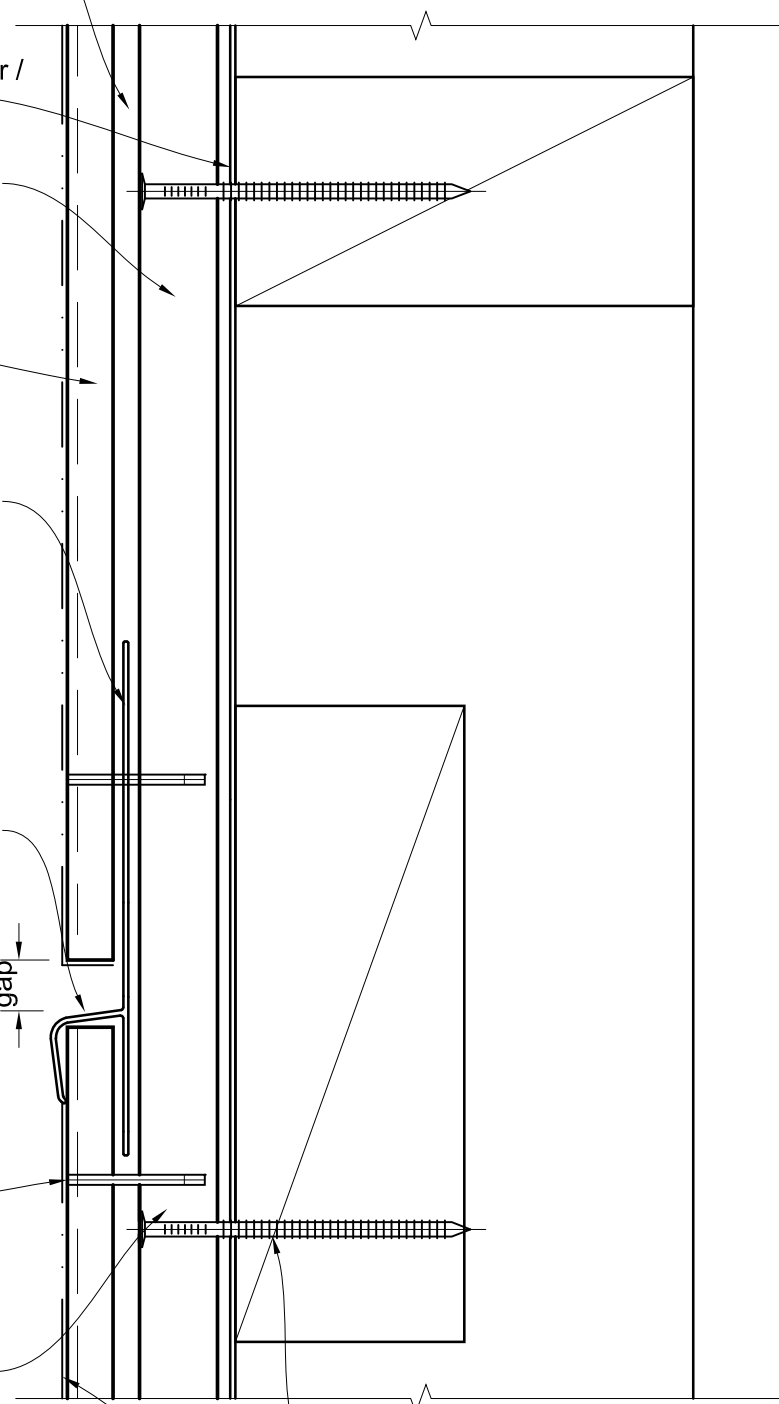

Figure 32: Soffit detail

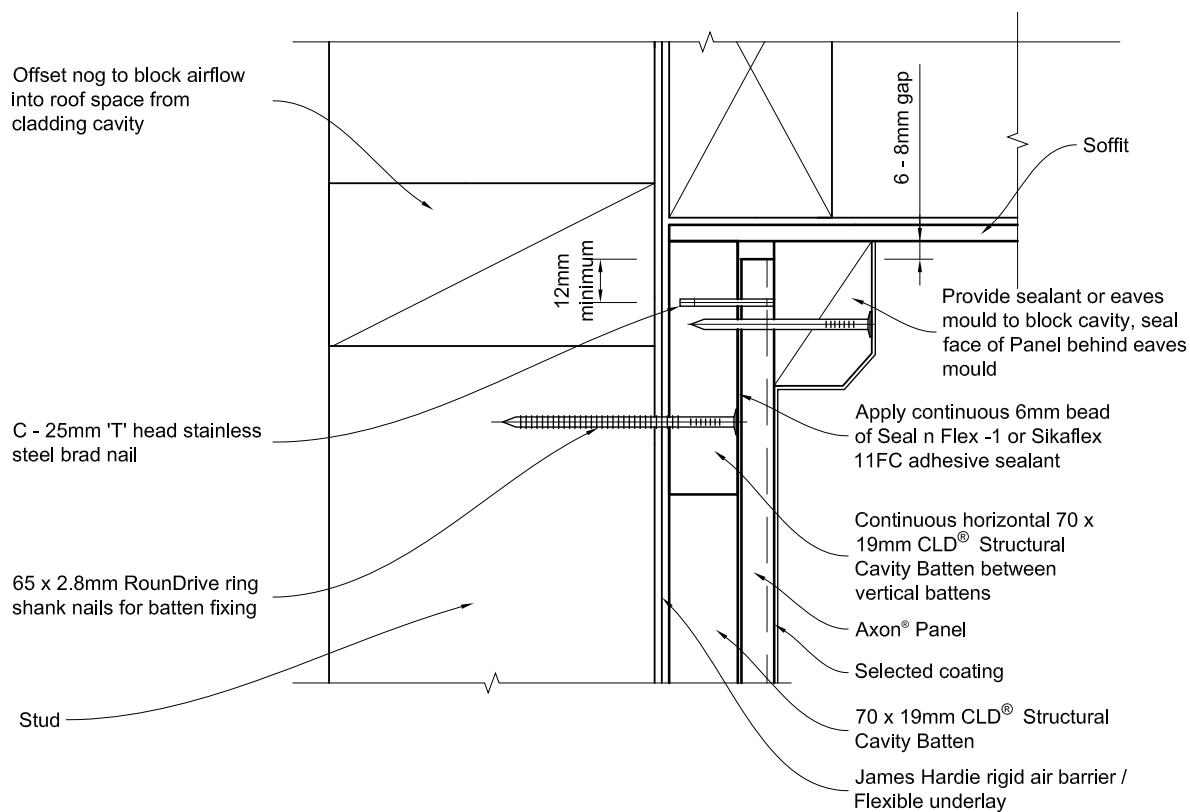

Figure 33: External corner at 'h' mould joint detail

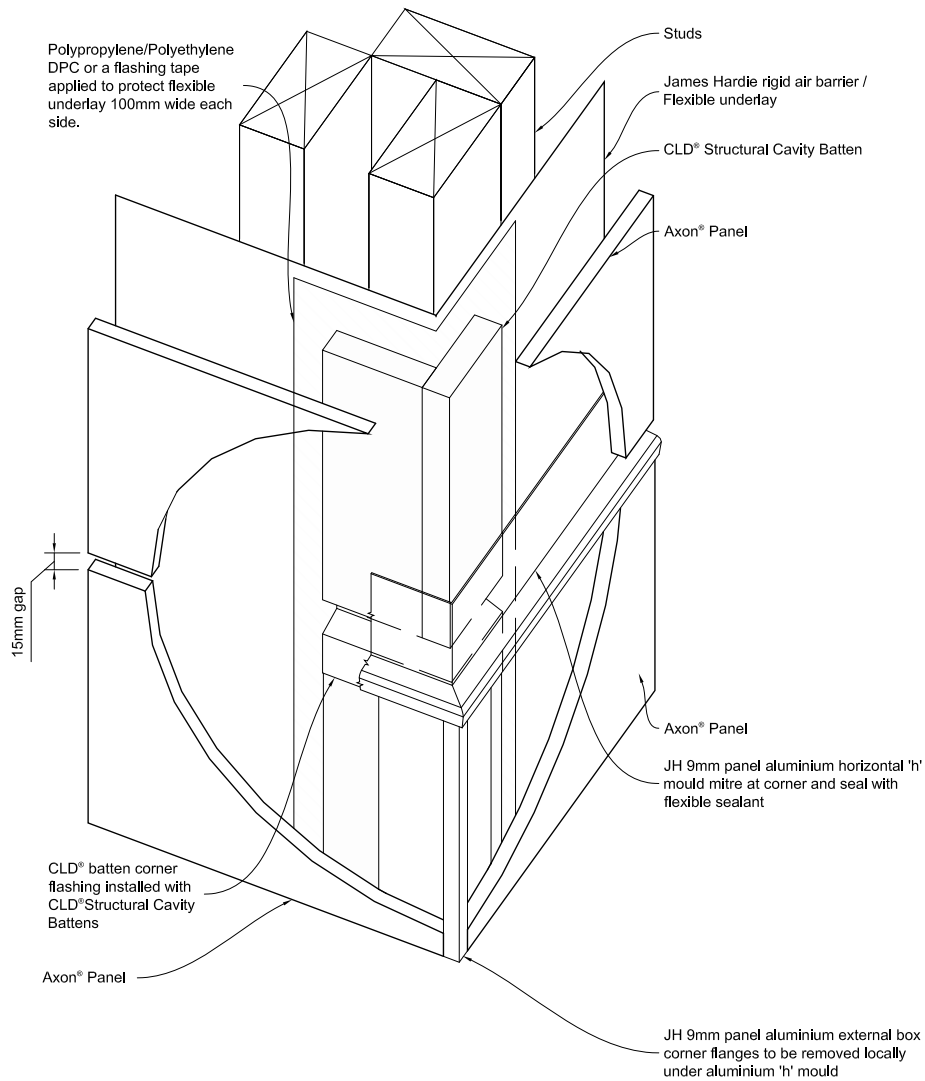

Figure 34: Cavity pipe penetration

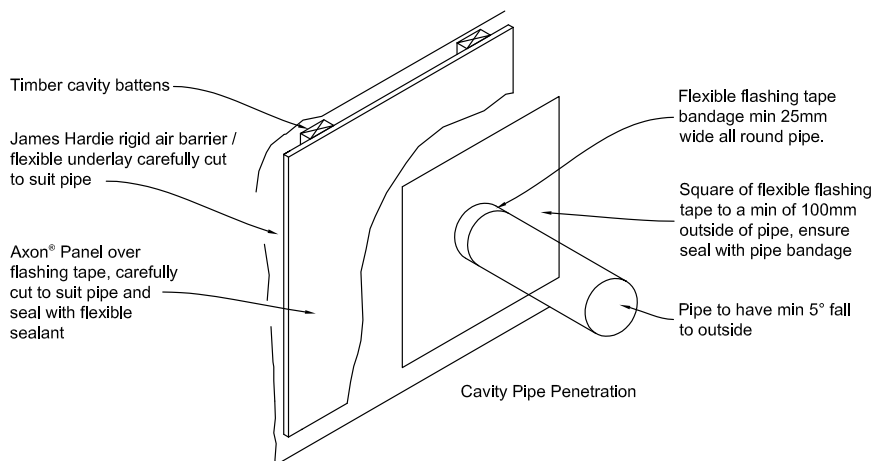



Figure 35: Internal corner at 'h' mould joint detail

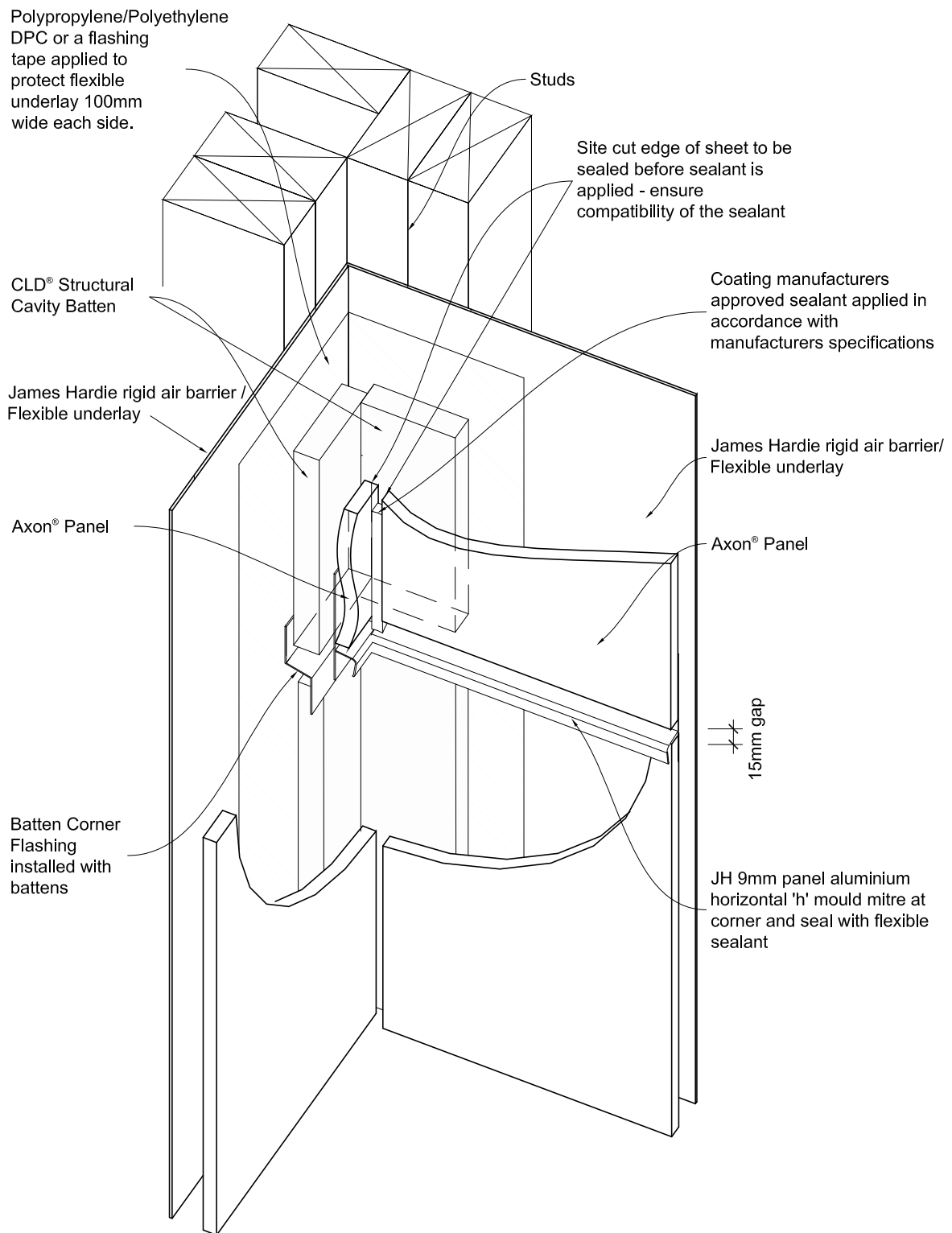

Figure 36: Aluminium 'h' mould joiner

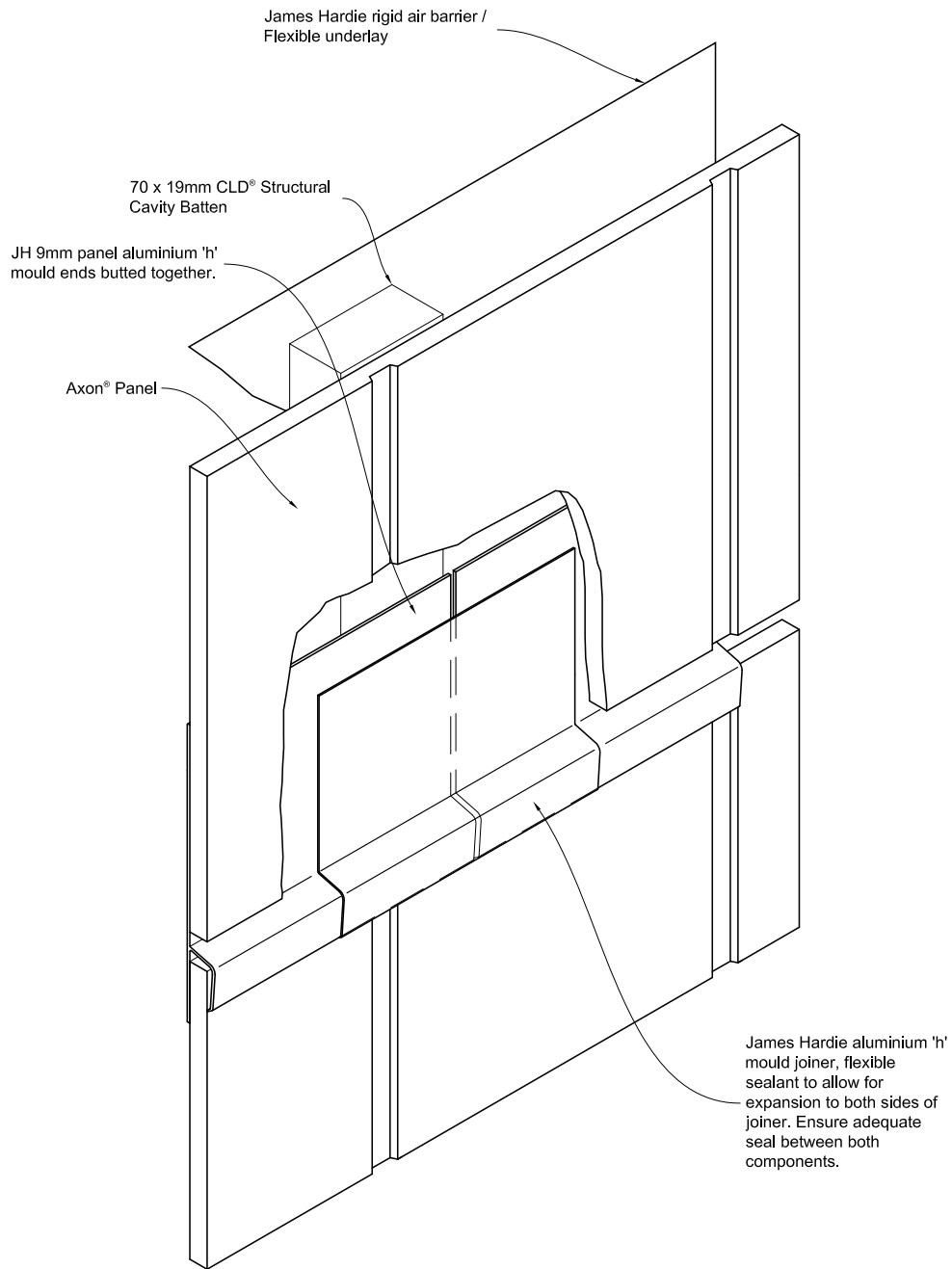
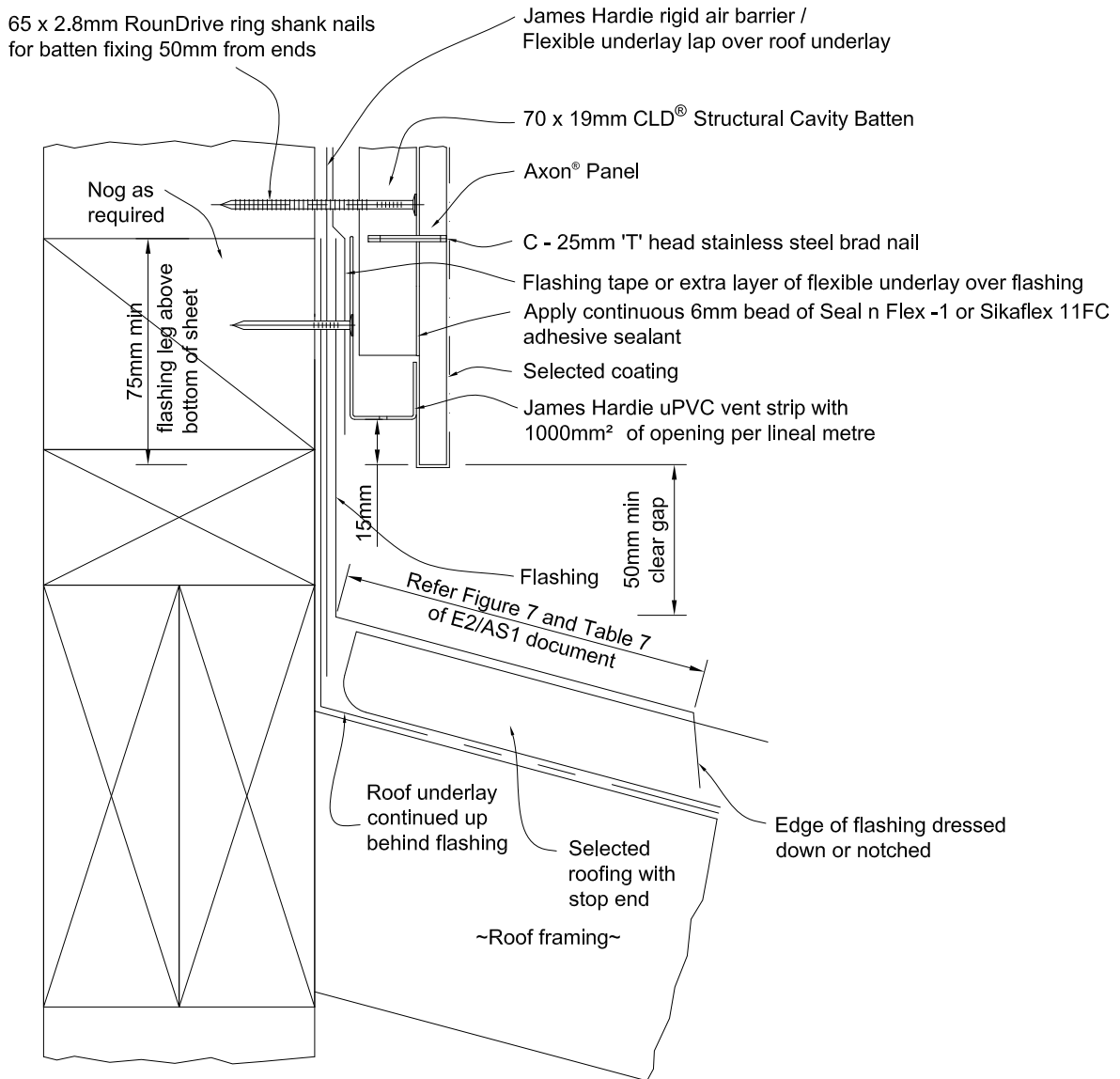
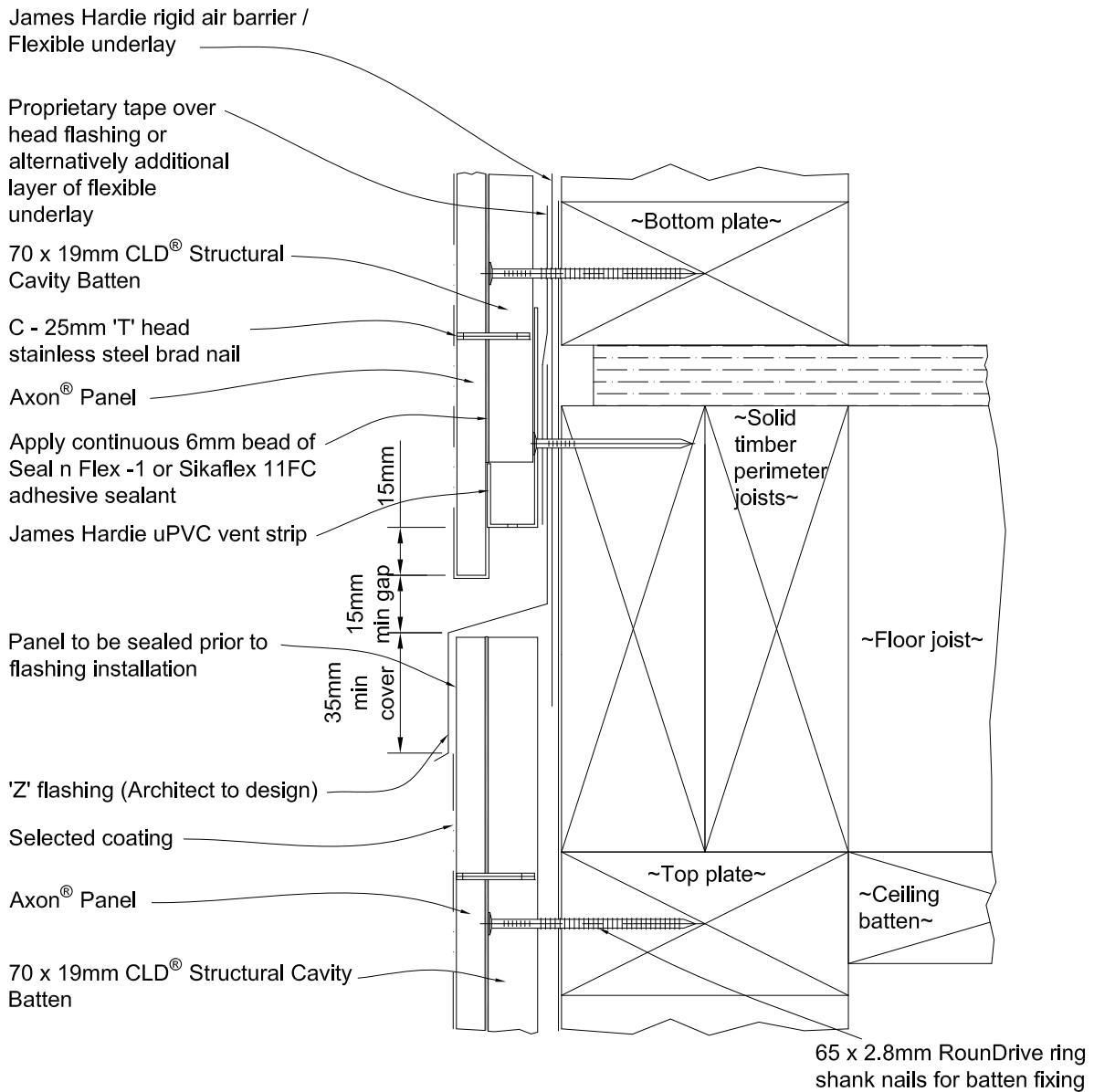

Figure 37: One piece apron flashing joint



When 50 year durability for flashing is required refer Table 20 NZBC E2/AS1 document.

Figure 38: Drained flashing joint at floor joist



**Step 1**

- Check Architect's plans for the type of flashing to be used.

**Step 2**

- Check fixing centres and edge distances.
- If top fixings are to be hidden by the Z flashing they will need to be fixed and sealed before the Z flashing is installed.
- Cut edges need to be primed with sealer.

**Step 3**

- When 50 year durability is required refer Table 20 E2/AS1.

**Step 4**

- The flashing to be placed in the centre of the floor joists. Do not fix CLD® Structural Cavity Battens or panels into floor joists.

Figure 39: Meter box at sill

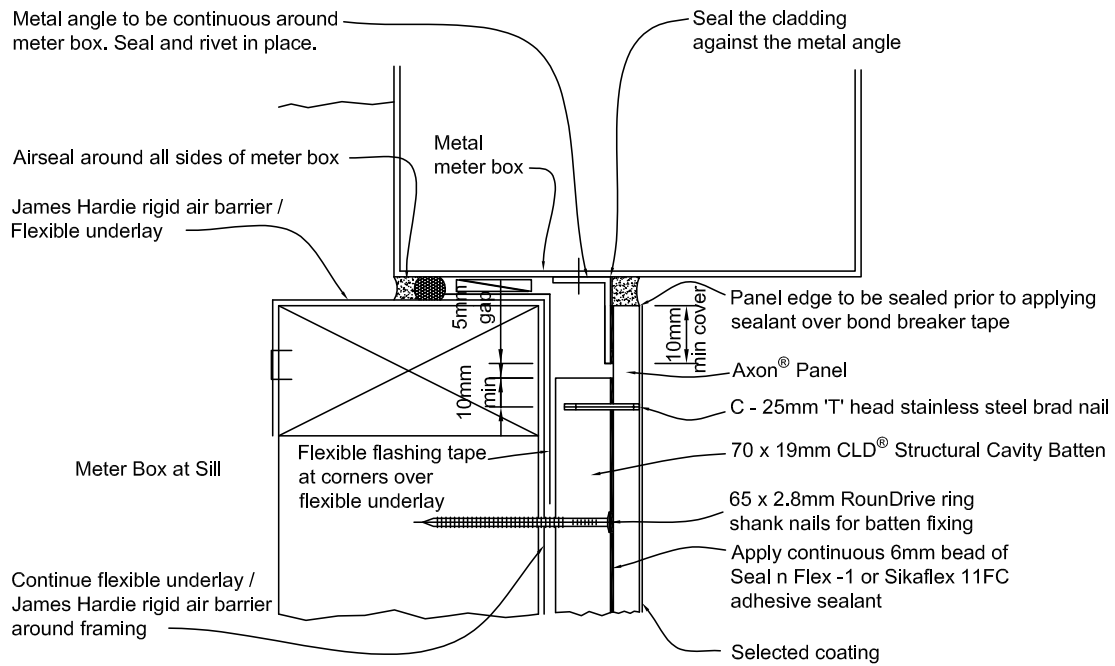

**Note:** When James Hardie rigid air barrier is used flashing tape or flexible underlay to be applied to the entire meter box sill.

Figure 40: Meter box at jamb

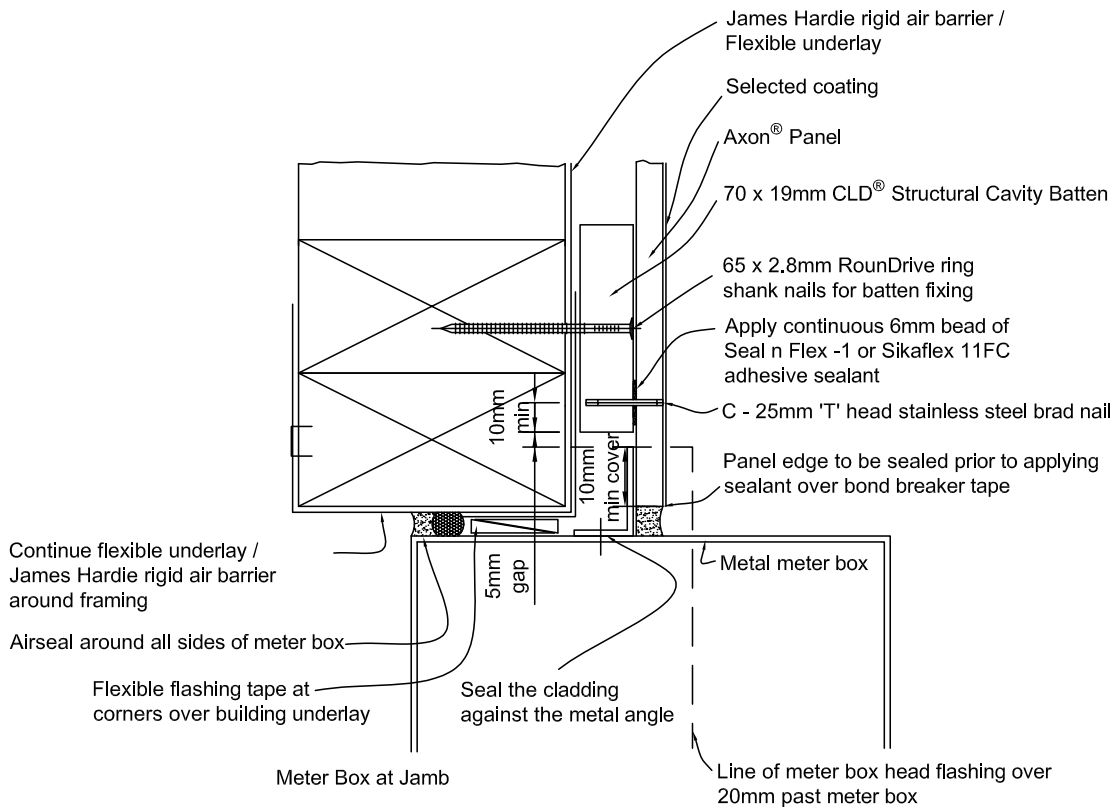

**Note:** When James Hardie rigid air barrier is used flashing tape or flexible underlay to be applied to the entire meter box jamb.

Figure 41: Meter box at head

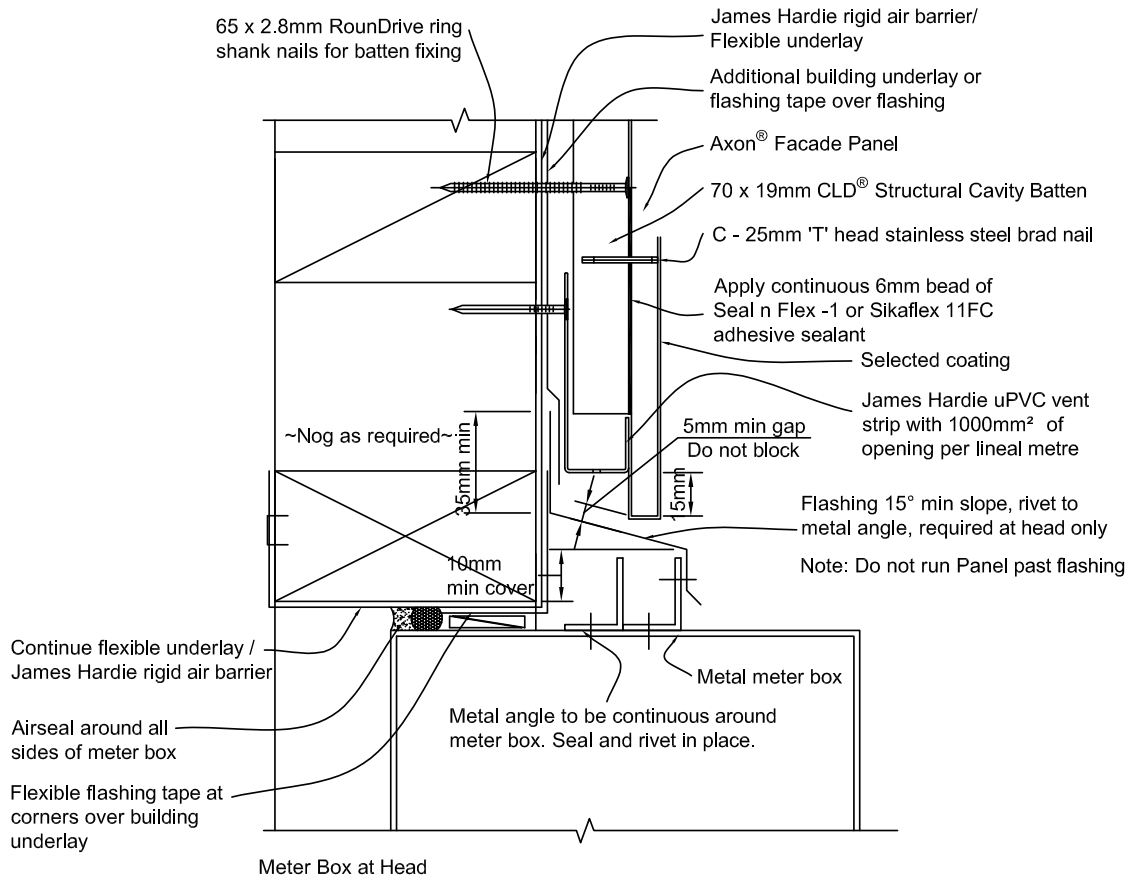

**Note:** When James Hardie rigid air barrier is used flashing tape or flexible underlay to be applied to the entire meter box head.

Figure 42: Garage door jamb

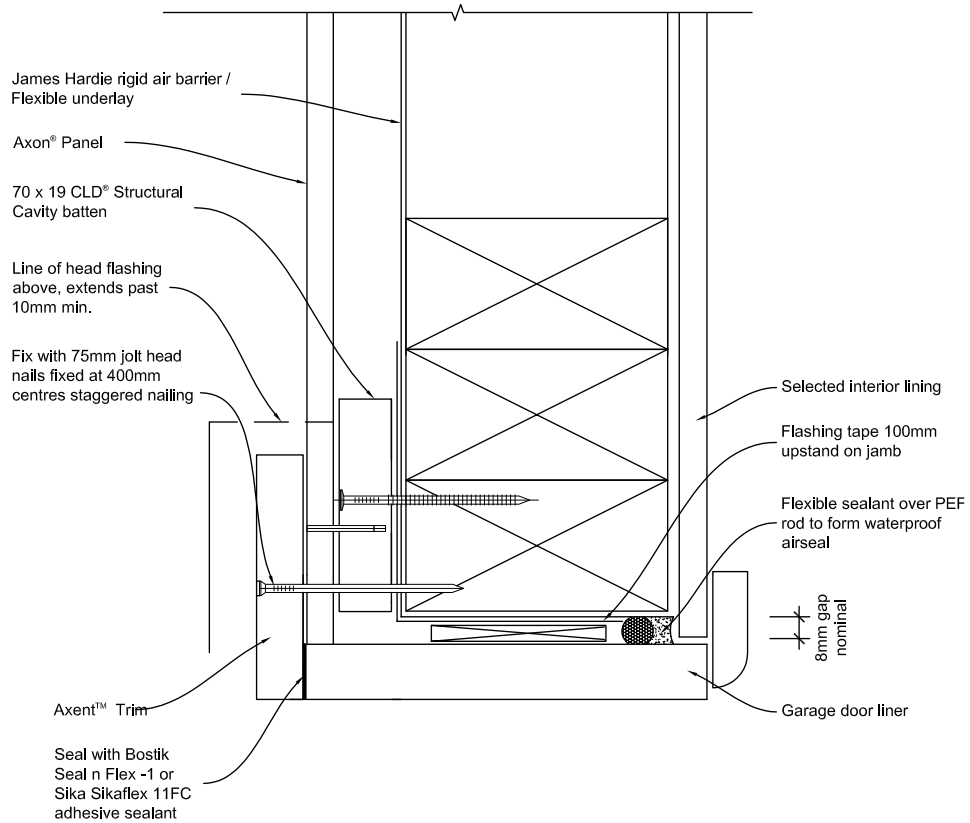
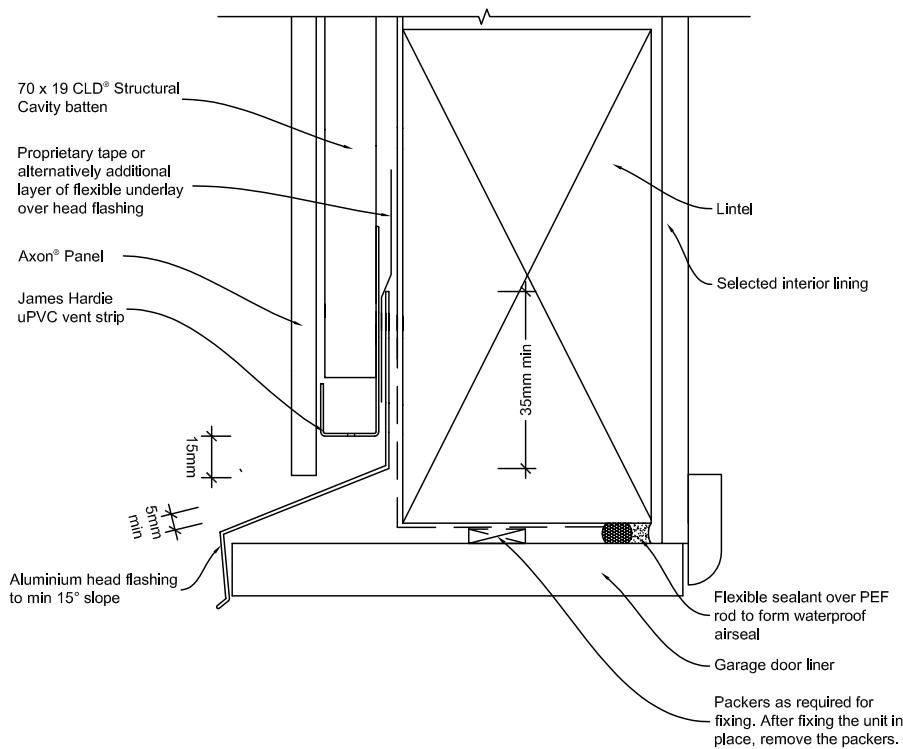

Figure 43: Garage door head



Sealant must be applied between head flashing and door liner in VH and EH wind zones and SED wind pressures.

Figure 44: Junction between Axon Panel and fascia board

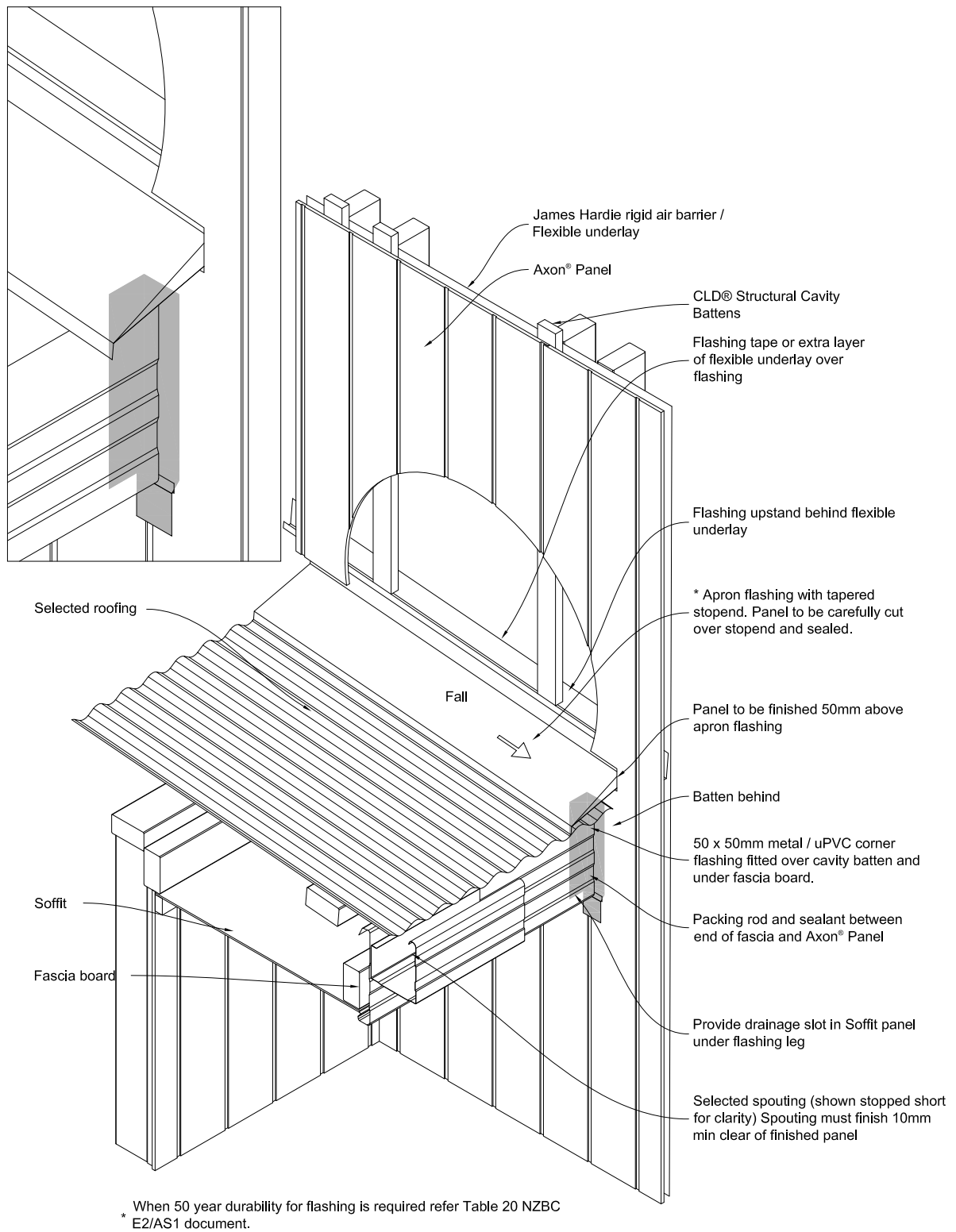
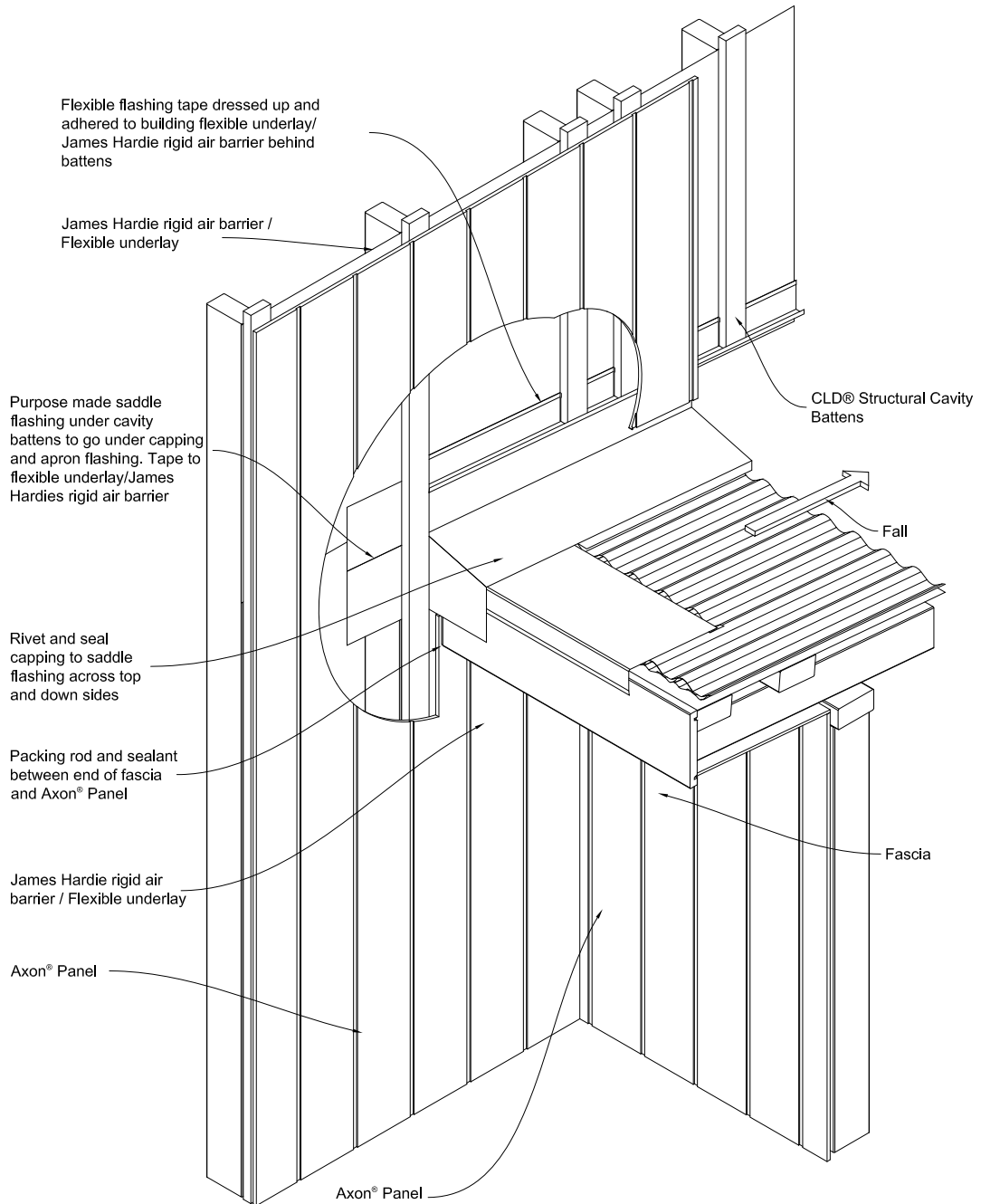



Figure 45: Enclosed roof to wall intersection





# Product Warranty



James Hardie New Zealand Limited (“James Hardie”) warrants for a period of 15 years from the date of purchase that the Axon™ Panel and CLD™ Structural Cavity Battens (the “Product”), will be free from defects due to defective factory workmanship or materials and, subject to compliance with the conditions below, will be resistant to cracking, rotting, fire and damage from termite attacks to the extent set out in James Hardie’s relevant published literature current at the time of installation. James Hardie warrants for a period of 15 years from the date of purchase that the accessories supplied by James Hardie will be free from defects due to defective factory workmanship or materials.

Nothing in this document shall exclude or modify any legal rights a customer may have under the Consumer Guarantees Act or otherwise which cannot be excluded or modified at law.

## CONDITIONS OF WARRANTY:

The warranty is strictly subject to the following conditions:

- a) James Hardie will not be liable for breach of warranty unless the claimant provides proof of purchase and makes a written claim either within 30 days after the defect would have become reasonably apparent or, if the defect was reasonably apparent prior to installation, then the claim must be made prior to installation.
- b) This warranty is not transferable.
- c) The Product must be installed and maintained strictly in accordance with the relevant James Hardie literature current at the time of installation and must be installed in conjunction with the components or products specified in the literature. Further, all other products, including coating and jointing systems, applied to or used in conjunction with the Product must be applied or installed and maintained strictly in accordance with the relevant manufacturer’s instructions and good trade practice.
- d) The project must be designed and constructed in strict compliance with all relevant provisions of the current New Zealand Building Code (“NZBC”), regulations and standards.
- e) The claimant’s sole remedy for breach of warranty is (at James Hardie’s option) that James Hardie will either supply replacement product, rectify the affected product or pay for the cost of the replacement or rectification of the affected product.
- f) James Hardie will not be liable for any losses or damages (whether direct or indirect) including property damage or personal injury, consequential loss, economic loss or loss of profits, arising in contract or negligence or howsoever arising. Without limiting the foregoing James Hardie will not be liable for any claims, damages or defects arising from or in any way attributable to poor workmanship, poor design or detailing, settlement or structural movement and/or movement of materials to which the Product is attached, incorrect design of the structure, acts of God including but not limited to earthquakes, cyclones, floods or other severe weather conditions or unusual climatic conditions, efflorescence or performance of paint/coatings applied to the Product, normal wear and tear, growth of mould, mildew, fungi, bacteria, or any organism on any Product surface or Product (whether on the exposed or unexposed surfaces).
- g) All warranties, conditions, liabilities and obligations other than those specified in this warranty are excluded to the fullest extent allowed by law.
- h) If meeting a claim under this warranty involves re-coating of Products, there may be slight colour differences between the original and replacement Products due to the effects of weathering and variations in materials over time.

Disclaimer: The recommendations in James Hardie’s literature are based on good building practice, but are not an exhaustive statement of all relevant information and are subject to conditions (c), (d), (f) and (g) above. James Hardie has tested/assessed the performance of the Axon™ Panel when installed in accordance with the Axon™ Panel technical specification, in accordance with the standards and verification methods required by the NZBC and those test results demonstrate the product complies with the performance criteria established by the NZBC. However, as the successful performance of the relevant system depends on numerous factors outside the control of James Hardie (e.g. quality of workmanship and design) James Hardie shall not be liable for the recommendations made in its literature and the performance of the relevant system, including its suitability for any purpose or ability to satisfy the relevant provisions of the NZBC, regulations and standards, as it is the responsibility of the building designer to ensure that the details and recommendations provided in the relevant James Hardie installation manual are suitable for the intended project and that specific design is conducted where appropriate.

Copyright April 2019. © James Hardie New Zealand Limited. TM and ® denotes a Trademark or Registered Mark owned by James Hardie Technology Limited.

Except for Tyvek® and Inseal® which are Registered Marks owned by their registered owners.

