



# CANTILEVER MASONRY RETAINING WALLS

FIRTH TECHNICAL SOLUTIONS



## INTRODUCTION

This section has been prepared to provide designers, local authorities and builders with some standard design details for Firth reinforced concrete masonry retaining walls.

It is emphasised that where loading conditions or soil types are likely to be outside the criteria given then **professional engineering advice must be sought**.

The principal advantages of reinforced concrete masonry walls over their reinforced concrete counterparts are the elimination of shuttering and the uniformity of the concrete surface texture. Two types of wall more commonly encountered on the building site have been considered, as follows (refer Figure 1):

**Type I** is used when excavation is below the level of a neighbouring property and is to be built as close as possible to the boundary.

**Type II** is used when filling against a neighbouring boundary.

Type II walls are generally more structurally efficient than Type I walls, but foundation detailing is more complicated and additional attention is required to waterproofing detailing at the base, when the wall forms part of a habitable space.

The Type I walls only allow for the optional additional gravity effects of loading from two storey light timber framing or one storey timber framing with 90mm brick veneer finish, in accordance with NZS3604.

## SELECTION OF RETAINING WALL

### Boundary and Site Conditions

By reference to the particular site conditions the type of wall to be used can be selected, refer to Figure 1, Type I or II.

Note the minimum level distance requirement (except where a specified backslope angle exists behind the wall). If this cannot be met then professional engineering advice must be sought in order that the wall design can be amended.

### Soil Conditions

By reference to the soil conditions on the site, a particular soil type can be selected from Table 1. Often the local territorial authority will have the soil types designated within its area and hence may require a specific soil type to be used in the design. The design

charts provided have classed different soils into three types for design simplicity. These are shown in Table 1.

Reference should be made to the local territorial authority as to its requirements for soil types.

If soil types outside the classes listed exist, then professional engineering advice must be sought.

### Loading Conditions

Design charts have been produced for:

- Level ground and no water pressure\*.
- Level ground, no water pressure\*, and a domestic driveway (2.5 kPa surcharge).
- Maximum backslope angle of soil retained, no water pressure\* or other surcharge present.

Loading conditions (a), (b), or (c) must be selected.

Only Type I walls allow for the optional additional gravity effects of loading from two storey light timber framing or one storey timber framing with 90mm brick veneer finish, in accordance with NZS3604. Where greater vertical loads are encountered from a structure over the retaining wall (up to 100kN/m run of wall) alternative designs are available in NZS4229 Appendix C.

It is **vital** to ensure that adequate drainage is provided behind the retaining wall. Where loading conditions are beyond the above limitations then professional engineering advice should be sought.

\* An allowance for pore water pressure in clay soils only is included in the design.

### Construction Methods

Two standards of criteria on construction methods have been set down in the design tables:

- Construction without Supervision.*  
*Grade B.*  
Inspection by the designer or a competent nominated representative is required during construction.
- Construction without Supervision.*  
*Grade C.*  
This category is intended where supervision is not provided. This grade shall be used for retaining walls having a maximum retained soil height up to 1.5m.

The use of the terms Grade B and Grade C arises from NZS4230:1990 "Code of practice for the Design of Masonry Structures" and NZS4229:1998 "Concrete buildings not requiring specific design".

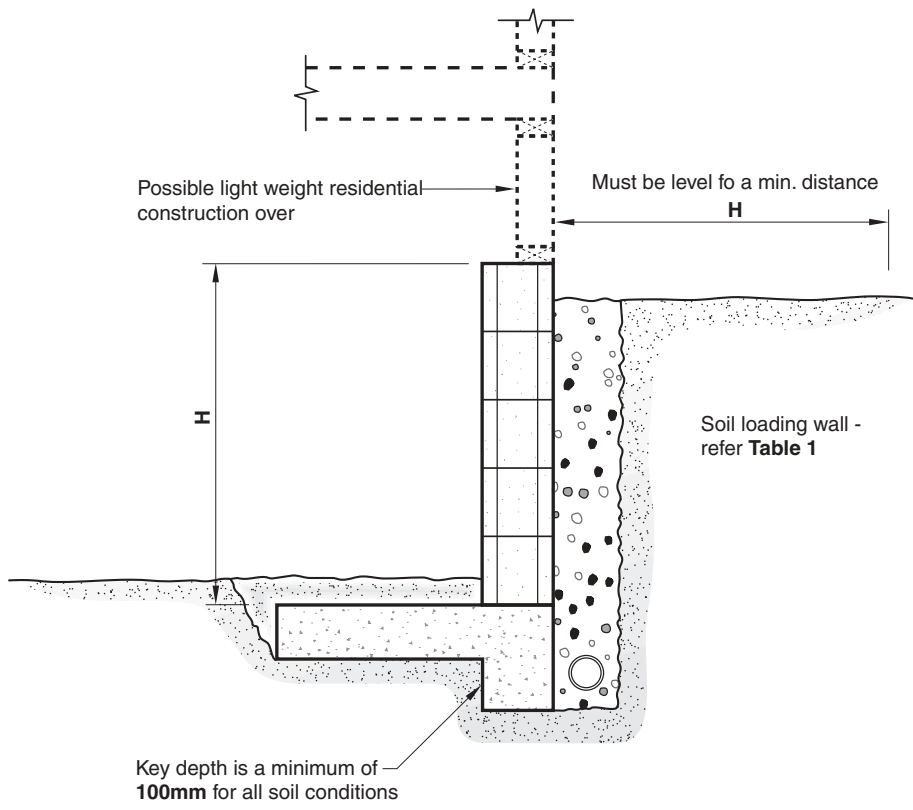

**TYPE I WALL**

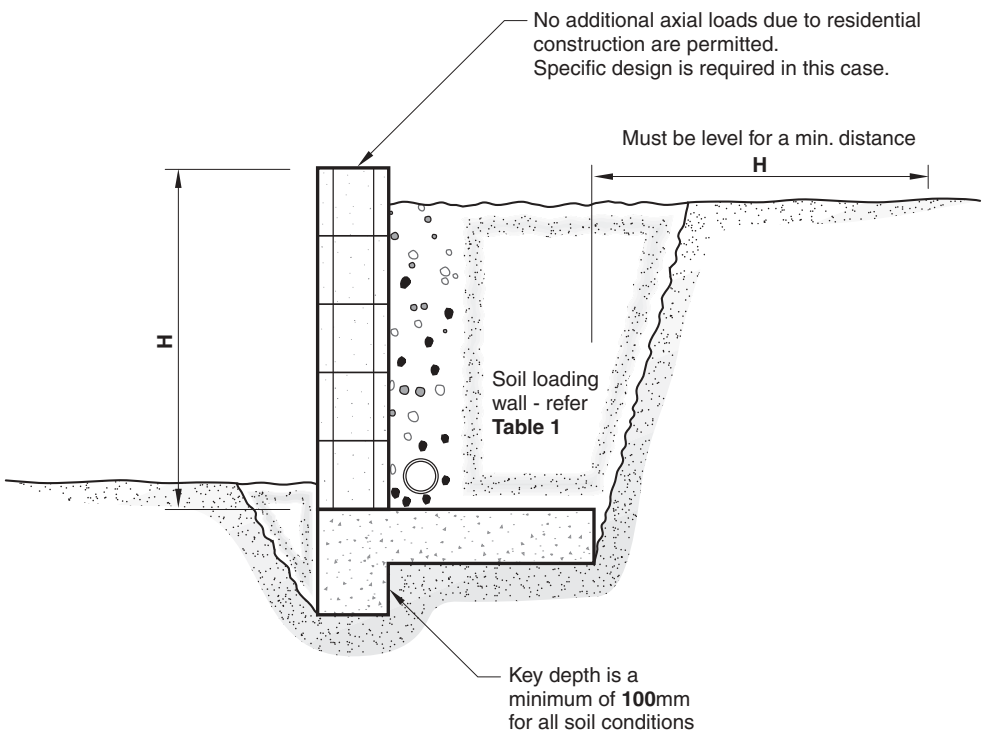

**TYPE II WALL**

**Figure 1** Key to Wall Types/Loads Permitted

A **registered mason** is qualified in structural concrete masonry and is acceptable to most local authorities as able to provide a producer statement for workmanship in accordance with NZS4210.

## SPECIFICATIONS OF MATERIALS

### Concrete for Footings

Concrete shall comply with NZS3109:1995 for concrete having a minimum crushing strength of 20.0 Mpa at 28 days.

*Ready mixed concrete should be ordered having 20mm maximum size aggregate, 20Mpa strength and with a 100mm slump.*

### Concrete for Infilling

Concrete infill grout shall comply with NZS4210 “Masonry Construction: Materials and Workmanship”, having minimum crushing strength of 17.5 Mpa at 28 days and a spread between 450-530mm when tested in accordance with the appropriate test requirements of NZS3112:1986 “Specification for Methods of Test for Concrete”.

*When the minimum dimension of the grout core is less than 60mm, then a fine grout consisting of concreting sand and cement should be used, otherwise a coarse grout is required with maximum aggregate size of 12.5mm or 19.0mm.*

### Mortar for Laying Blocks

Mortar shall comply with NZS4210 “Masonry Construction: Materials and Workmanship”, having a minimum compressive strength of 12.5 Mpa when tested in accordance with Appendix 2.A of NZS4210.

### Reinforcing Steel

Reinforcing steel should be deformed high yield steel bars conforming to the new combined Australian/New Zealand Standard “Steel Reinforcing Materials” (refer Use of Design Charts notes with reference to existing and future steel grades).

**Note:** The design charts have been created using the soon to be introduced Grade 500 Mpa Seismic reinforcing steel and joint Australian/New Zealand reinforcing steel standard. Until this steel becomes available the charts currently existing in the Masonry Manual shall continue to be used for design purposes.

## Masonry Construction

Wall construction shall follow the provisions of NZS4210. Construction will predominantly use open ended, depressed web units; ie 1516, 2016, 2516; or where available H block configuration, eg H2016. All cells are to be filled with grout.

### Design Notes

The design charts were produced from computer print out data supplied by the consultants Spencer Holmes Ltd in response to a commission by the New Zealand Concrete Masonry Association to investigate masonry retaining walls for domestic construction.

The criteria used by the consultants were as follows:

- The retained soil at the top of the wall from the back of the footing heel is level for a distance equal to the height of wall (except for tables where a specified backslope angle exists). All soil contained from the back of the wall to a 45° line from the base of the footing must be of the type assumed in the design from Table 1, or where backfilling has taken place, must be granular with a minimum  $\phi = 35^\circ$  and maximum  $\gamma_d = 19.6 \text{ kN/m}^3$
- The walls are not designed for the forces due to compacting machinery working on the retained soil. Adequate precautions, eg. shorting, strutting, etc. must be taken to ensure no damage occurs to the wall during this operation.
- The design considers stability of the wall for sliding, overturning and bearing on the soil immediately adjacent to the wall. Overall stability of the soil mass has not been considered.
- A drainage layer of suitable granular material is provided at the back of the wall, with a perforated pipe at the base discharging to the open. Surface water must also be prevented from accumulating at the top of the wall and overloading the drainage system.
- The assumed weight of materials is:

Concrete and Blockwork Soil	23.5 kN/m <sup>3</sup>
Uncompacted gravelly sands or clay	16.7 kN/m <sup>3</sup>
Dense gravelly sands or gravels	19.6 kN/m <sup>3</sup>
Pumice	2.7 kN/m <sup>3</sup>
- Blockwork and concrete are designed to “ultimate limit state” concepts as outlined in NZS4203:1992 “General Structural Design and Design Loadings for Buildings”. Soil loading concepts used are

recommended by the New Zealand Geomechanics Society and the New Zealand Structural Engineering Society in a seminar entitled "Limit State Design of Retaining Walls and Foundations for Geotechnical and Structural Engineers". The load and resistance are factored separately reflecting the uncertainty associated with each:

- The following load factors were used:
  - Loads generated by static earth pressure 1.6
  - Restoring Gravity Loads 0.9
- The following capacity reduction factors were used:
  - Soil bearing capacity  $\phi = 0.5$
  - Sliding Resistance  $\phi = 0.8$
- Seismic load combinations are not considered to be critical for the height and nature of the walls encountered in this design. It is probable that some additional wall rotations will take place in some conditions where ultimate limit state earthquake loadings are imposed. However it is considered that collapse conditions will not occur. This is consistent with the requirements of NZS4203, the Loadings Code.
- Calculations assume a minimum 100mm cover of earth or paving materials on top of projecting footings. Where footings are constructed integrally with a floor slab and there is no such cover it is assumed that the slab will provide the additional resistance to overturning required.
- Assumed soil parameters**

The following soil types have been grouped together to provide three soil types for ease of use.

**Table 1** Soil types used in design

Soil Type	Classes of soil included	Design Parameters		
		$\gamma$ (kN/m <sup>3</sup> )	$\phi$ (°)	C (kPa)
A	dense gravel	19.6	30	0
B*	loose gravel generally sand sandy gravel pumice	16.7	30	0
C	clay	16.7	25	12

\* The design parameters for each of the soil classes varies in practice. The most unfavourable conditions for the group have been given.

Soil forces are calculated using the Coulomb active earth pressure theory assuming wall movements, lateral and rotational, are sufficient to allow active pressure to develop and that wall/soil friction can develop.

For both cohesive and granular soil types, the soil and surcharge are assumed to act at an angle of either two thirds  $\phi$  or  $\phi$ . The first value applies to Wall Type I and approximates the effect of wall friction. The second value applies to Type II Walls where the "virtual back" of the wall is a plane through the soil itself, and wall friction is replaced by internal friction of the soil.

When calculating the passive soil pressure at the toe of the footing, cohesive soils are assumed to be fully drained (ie. no pore water pressures are present). The passive pressure on the toe is taken as acting over the entire depth from the soil level to the base of the key; the full value is used.

For cohesive type soils the effects of pore water pressure are assessed as shown in Figure 2, to allow for slow drainage within the retained soil.

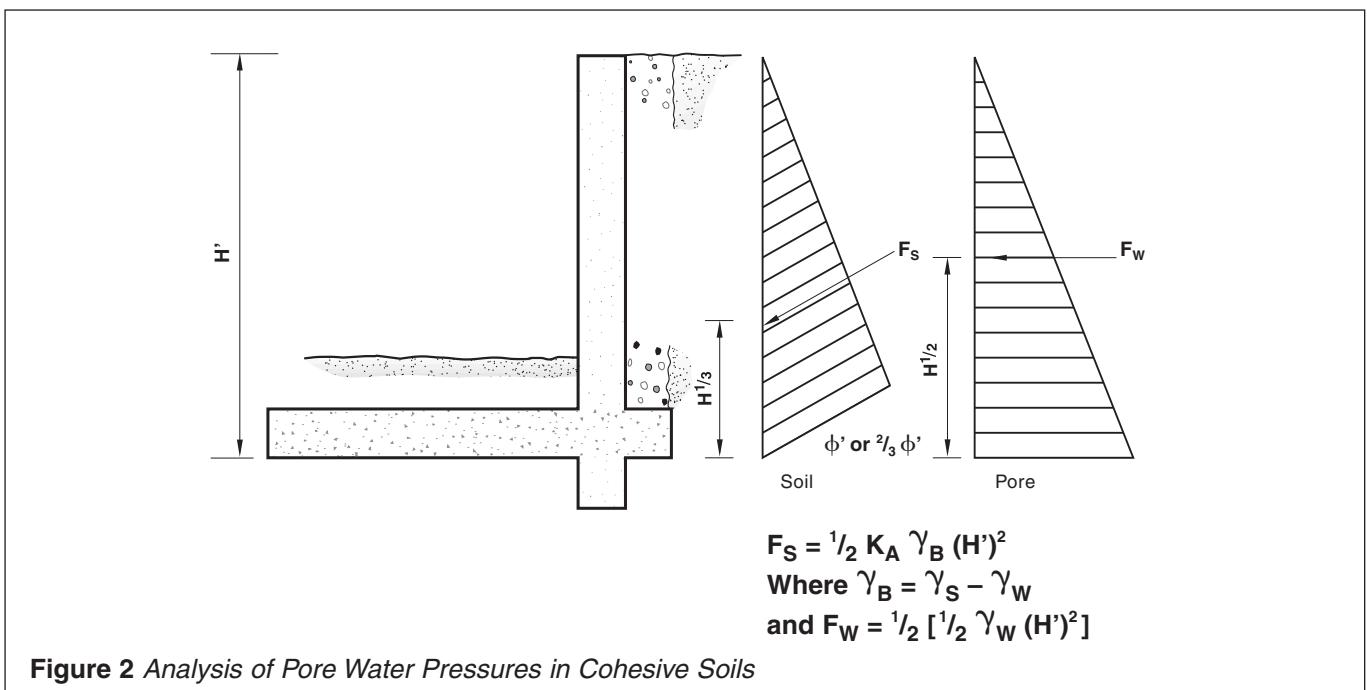

**Note:** The pore water pressure assessed for the drained cohesive soil is half that for an undrained cohesive soil. Note that the soil pressure is computed using the submerged density  $\gamma_b$ , and that the pore water pressure is taken as acting at half the height.

The soil stress is assumed to be a uniform rectangular stress block over a portion of the footing. The minimum ultimate bearing pressure of the soil is assumed to be 300 kPa.

In cohesive soils, base adhesion contributes to the sliding resistance. The value of base adhesion used is  $C$  multiplied by the width of the footing over which ultimate soil bearing pressure develops (ie. the rectangular stress block).

The base friction coefficient is taken as  $\tan f$  in granular soils, and two thirds  $\tan f$  in cohesive soils where a key exists.

Buoyancy effects have not been considered.

• **Masonry Design**

The design has been based upon NZS4230:1990 “Code of Practice for the Design of Masonry Structures”. 60mm cover to reinforcing steel from soil side of the wall has been used for all walls. Refer to Figure 3 for construction details showing block layout, reinforcing location, bar bend radii, etc.

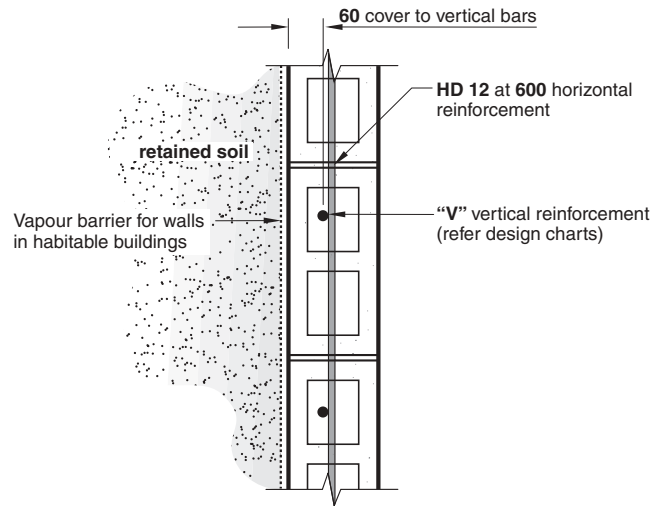

**PLAN VIEW - REINFORCEMENT PLACEMENT**

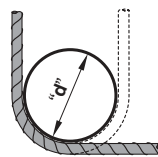

**BAR BEND RADII**

Bend bar around “d” diameter pin

- HD10 “d” = 50 mm
- HD12 “d” = 60 mm
- HD16 “d” = 80 mm
- HD20 “d” = 100 mm

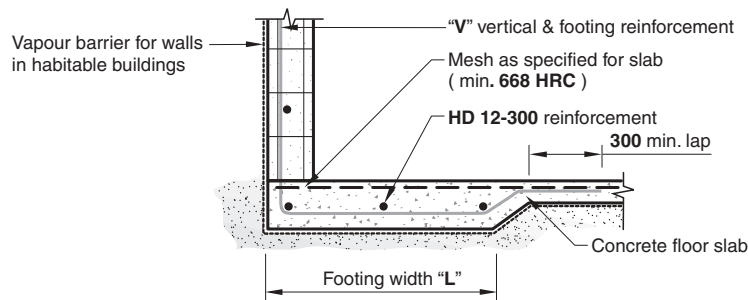

**SECTION THROUGH FOOTING WITH INTEGRAL FLOOR SLAB**

**Figure 3 Retaining Wall Details**



## Use of Design Charts

- By reference to boundary and site conditions, the appropriate wall type can be selected, Type I or II (see Figure 1).
- Select the appropriate soil type (see Table 1).
- Determine if a surcharge for light private vehicle parking is required, or if the retained soil will have a backslope angle.
- Reinforcement tables indicating the maximum height to be retained for the appropriate wall, soil types, and loading conditions, will determine whether a 140mm, 190mm, or a 240mm wall should be used. The top row for the 190mm series walls has been provided to give minimised footing dimensions for lower height wall options.
- Enter selected chart, using maximum height of soil retained, to read off reinforcing and minimum footing dimensions required.
- Where the footing is part of a substantial concrete slab (eg. house or garage floor slab in good ground) any key required can be omitted.
- Only Type I walls allow for the optional additional gravity effects of loading from two storey light timber framing or one storey timber framing with 90mm brick veneer finish, in accordance with NZS3604. Where greater vertical loads are encountered from a structure over the retaining wall (up to 100kN/m run of wall) alternative designs are available in NZS4229 Appendix C.

**Note:** The following charts have been created using the soon to be introduced Grade 500 MPa Seismic reinforcing steel and joint Australian/New Zealand reinforcing steel standard. Until this steel becomes available the charts currently existing in the Masonry Manual shall continue to be used for design purposes.

## EXAMPLES

The following examples intend to illustrate the use of the design charts:

### Example 1

A wall within a basement garage which as a substantial area of concrete slab and footings constructed on good ground is to retain sandy soil from the neighbouring property. It is directly adjacent

to the site boundary. The ground to be retained is flat for a distance of 3m from the wall face, is used as a domestic driveway, and is determined to be 2200mm above the top of the footing.

- As excavation cannot be under neighbours property use Type I wall.
- As domestic driveway use surcharge based charts.
- The soil is identified as being sandy therefore use soil B column.
- With 140mm Type I wall with surcharge and soil type B, the maximum permitted height is 1650mm. Therefore use 190mm Type I wall with surcharge.
- The design dimension table is then referenced and by scanning the Soil B column it is found that the closest greater “Maximum Height” retained is 2400mm, giving:

Reinforcing	HD16-400
Footing Length “L”	1350mm

The 400mm deep key may be omitted from the footing because of the presence of substantial area of attached slab and foundations.

### Example 2

A Type II wall, 1750mm high, is to be constructed in Soil B materials with a backslope of 10°. A 190mm wall is chosen and the “*Type II 190mm Retaining Wall – With Backslope*” chart is referenced.

- By entering the Soil B column it is found from the second and third rows down that either HD10-400 or HD12-600 can be used, and that the footing dimensions are the same for both cases. As the reinforcing weight, and hence cost, is approximately the same for both cases it is preferable to choose the option with the wider reinforcing spacing.
- The following design is therefore used:

Reinforcing	HD12-600
Footing Length “L”	750mm
Key Depth “K”	100mm

If, for this example, the backslope required was determined to be 20°, ie exceeds the 12° maximum slope provided on the design chart for this wall, specific design would be required by a qualified Engineer.

# TYPE I. 140mm RETAINING WALL – WITHOUT SURCHARGE

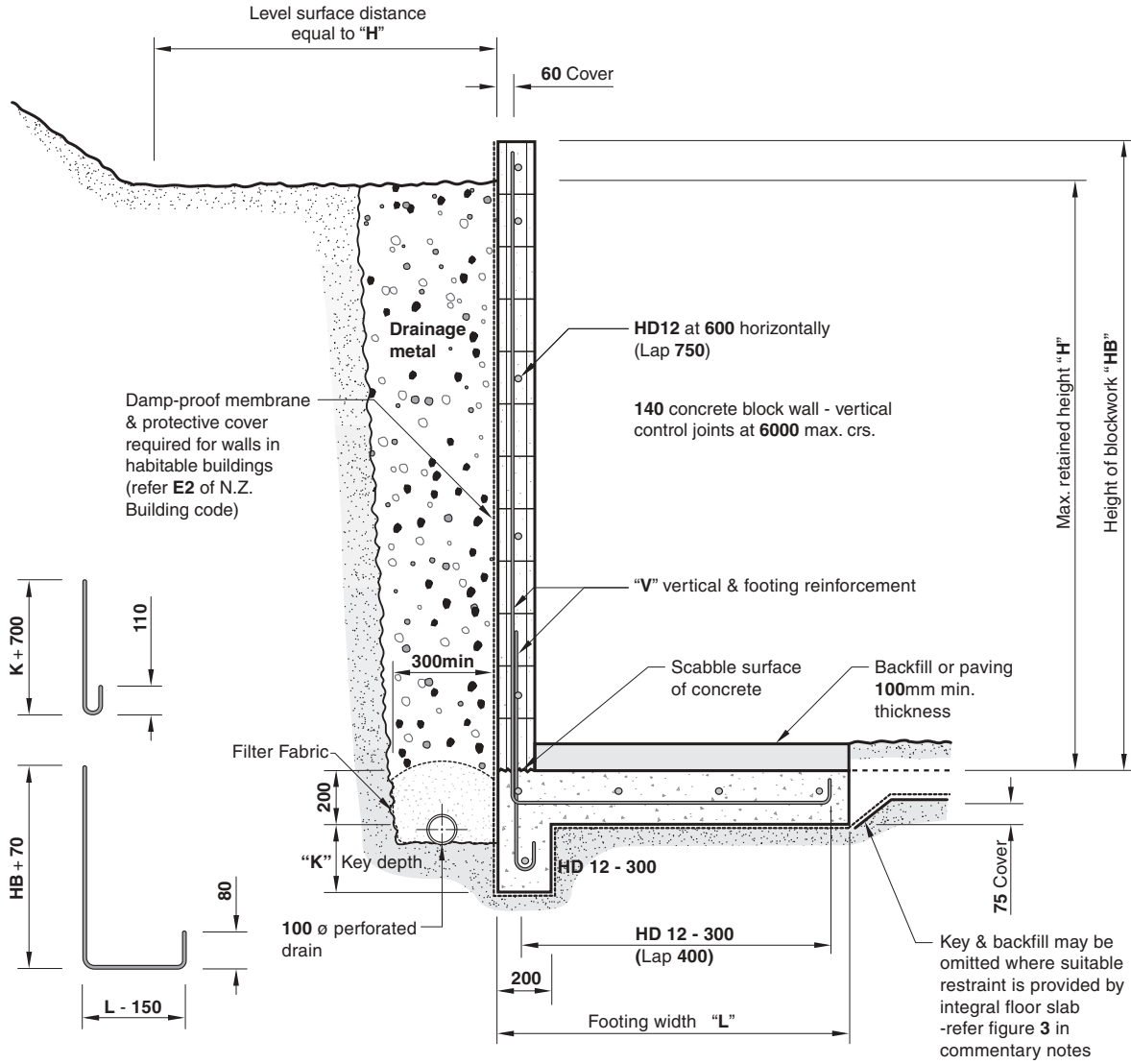

## BAR BENDING DIMENSIONS

## CROSS-SECTION OF RETAINING WALL

### NOTES

- Masonry designed to NZS4230 PART 1.
- Concrete foundation and grout infill strengths 20MPa at 28 days.
- Reinforcement is deformed 500 grade.
- Ultimate bearing pressure for footing taken as 300kPa.
- Drainage shall be a layer of suitable granular material with perforated pipe to an open end.
- Compaction forces from machinery are not included in the design.

	$\gamma$ kN/m <sup>3</sup>	$\phi$
7. Soil A includes • Dense Gravel	19.6	30
Soil B includes • Loose Gravel	16.7	30
• Gravely Sand	16.7	35
• Pumice Soil	12.7	35
Soil C includes • Weak Clay	16.7	25

Vertical and Footing Reinforcement "V"	SOIL A		SOIL B		SOIL C	
	Maximum height "H"		Maximum height "H"		Maximum height "H"	
	"L"	"K"	"L"	"K"	"L"	"K"
HD10-600	1000		1000		1000	
	500	100	450	100	850	200
HD10-600	1300		1400		1100	
	650	200	650	200	950	250
HD10-400	1500		1600		1200	
	800	250	800	200	1050	300
HD12-600	1500		1550		1200	
	800	250	750	250	1050	300
HD12-400	1650		1750		1400	
	900	300	900	300	1300	350

## DESIGN DIMENSIONS



# TYPE I. 140mm RETAINING WALL – WITH SURCHARGE

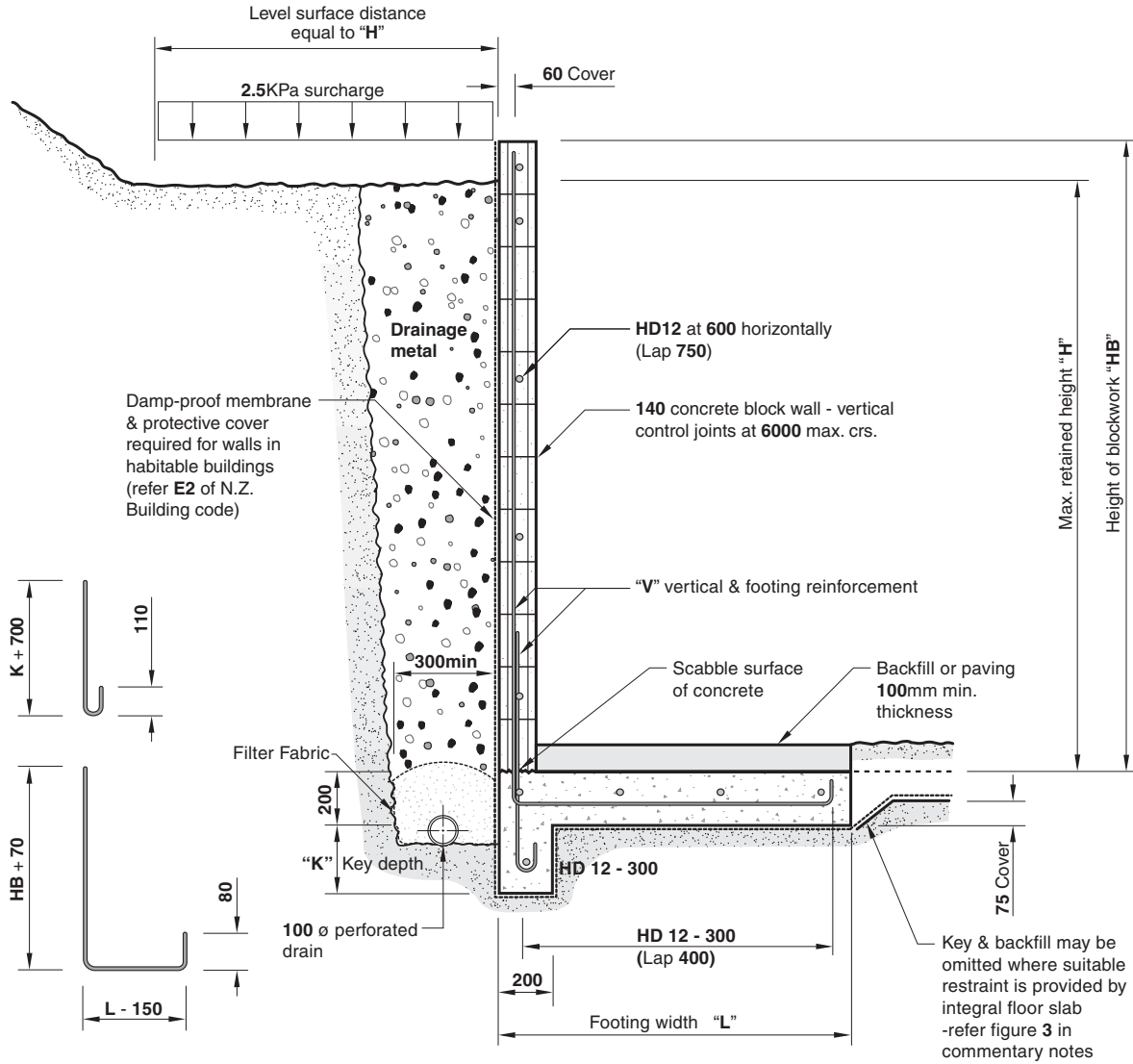

## BAR BENDING DIMENSIONS

## CROSS-SECTION OF RETAINING WALL

### NOTES

- Masonry designed to NZS4230 PART 1.
- Concrete foundation and grout infill strengths 20MPa at 28 days.
- Reinforcement is deformed 500 grade.
- Ultimate bearing pressure for footing taken as 300kPa.
- Drainage shall be a layer of suitable granular material with perforated pipe to an open end.
- Compaction forces from machinery are not included in the design.

	$\gamma$ kN/m <sup>3</sup>	$\phi$
7. Soil A includes • Dense Gravel	19.6	30
Soil B includes • Loose Gravel	16.7	30
• Gravely Sand	16.7	35
• Pumice Soil	12.7	35
Soil C includes • Weak Clay	16.7	25

Vertical and Footing Reinforcement "V"	SOIL A		SOIL B		SOIL C	
	Maximum height "H"		Maximum height "H"		Maximum height "H"	
	"L"	"K"	"L"	"K"	"L"	"K"
HD10-600	1000		1000		1000	
	550	150	550	150	950	250
HD10-600	1200		1250		1000	
	700	200	700	200	950	250
HD10-400	1400		1450		1150	
	800	250	800	250	1100	300
HD12-600	1350		1450		1150	
	800	250	800	250	1100	300
HD12-400	1550		1650		1300	
	900	300	900	300	1250	350

## DESIGN DIMENSIONS

# TYPE I. 140mm RETAINING WALL – WITH BACKSLOPE

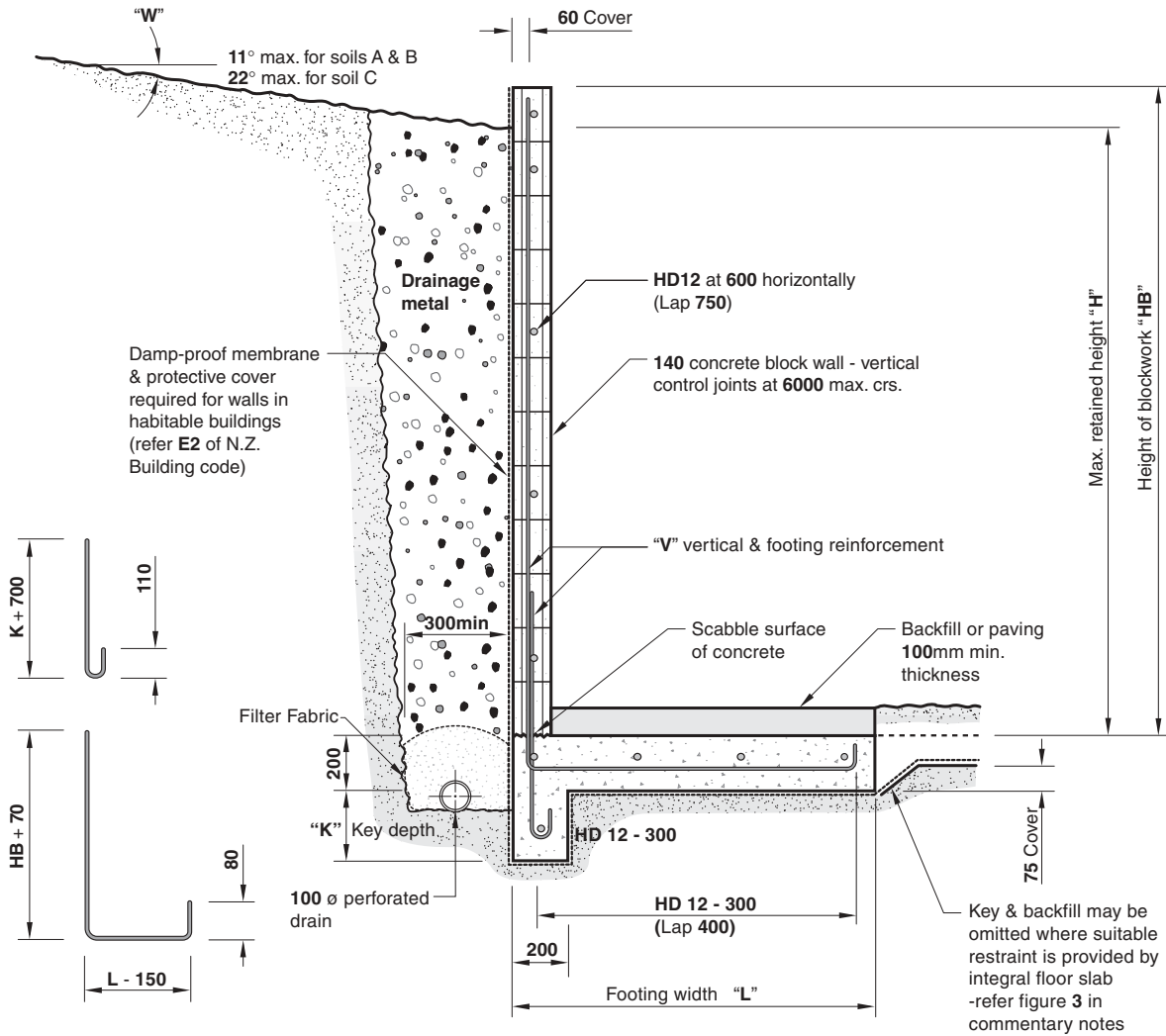

## BAR BENDING DIMENSIONS

## CROSS-SECTION OF RETAINING WALL

### NOTES

- Masonry designed to NZS4230 PART 1.
- Concrete foundation and grout infill strengths 20MPa at 28 days.
- Reinforcement is deformed 500 grade.
- Ultimate bearing pressure for footing taken as 300kPa.
- Drainage shall be a layer of suitable granular material with perforated pipe to an open end.
- Compaction forces from machinery are not included in the design.

	$\gamma$ kN/m <sup>3</sup>	$\phi$
Soil A includes • Dense Gravel	19.6	30
Soil B includes • Loose Gravel	16.7	30
• Gravely Sand	16.7	35
• Pumice Soil	12.7	35
Soil C includes • Weak Clay	16.7	25

Vertical and Footing Reinforcement "V"	SOIL A		SOIL B		SOIL C	
	Maximum height "H"		Maximum height "H"		Maximum height "H"	
	"L"	"K"	"L"	"K"	"L"	"K"
HD10-600	1000		1000		1000	
	550	150	550	150	950	250
HD10-600	1200		1250		1000	
	700	200	700	200	950	250
HD10-400	1400		1450		1150	
	800	250	800	250	1100	300
HD12-600	1350		1450		1150	
	800	250	800	250	1100	300
HD12-400	1550		1650		1300	
	900	300	900	300	1250	350

## DESIGN DIMENSIONS

# TYPE II. 140mm RETAINING WALL – WITHOUT SURCHARGE

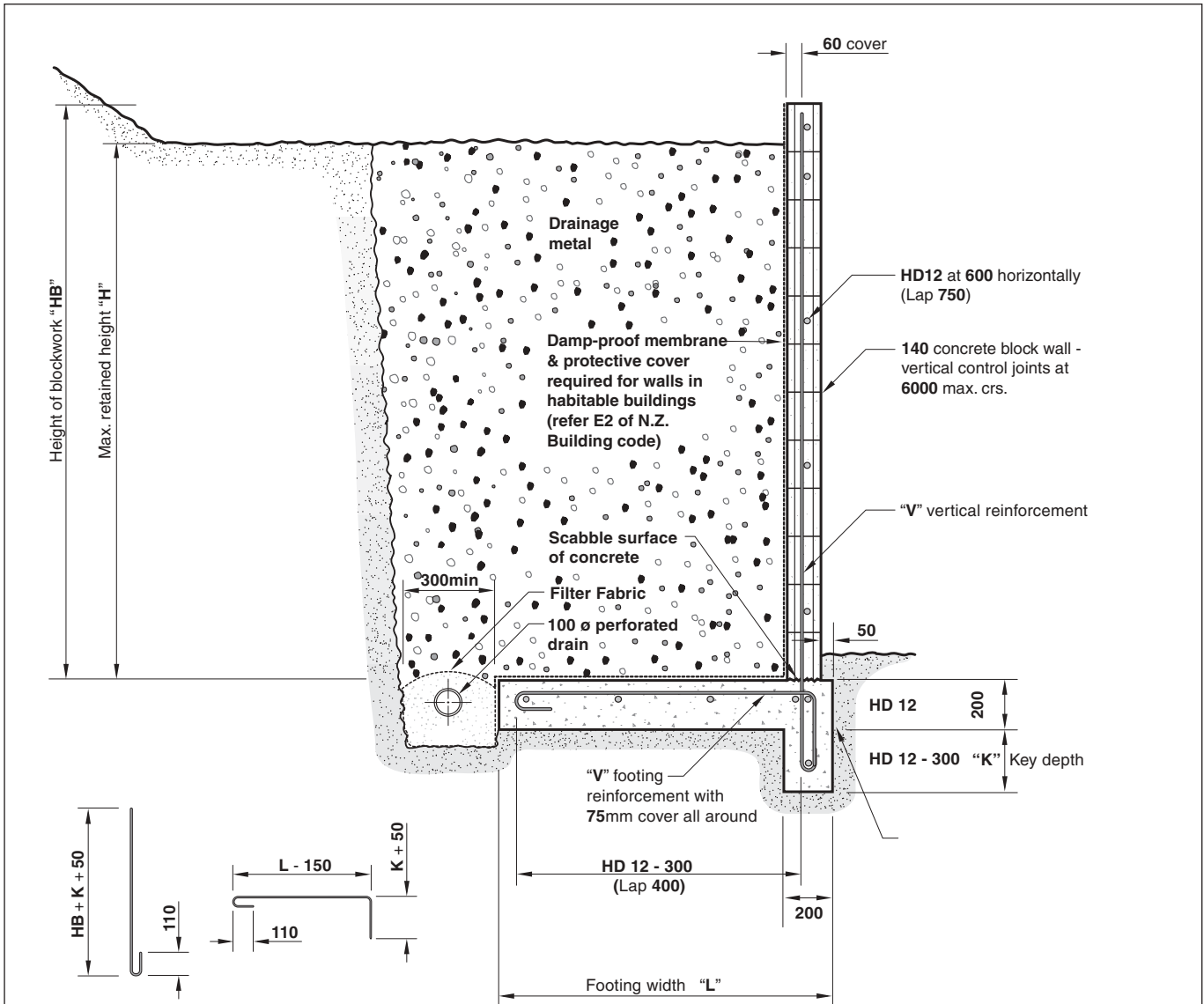

## BAR BENDING DIMENSIONS

## CROSS-SECTION OF RETAINING WALL

### NOTES

- Masonry designed to NZS4230 PART 1.
- Concrete foundation and grout infill strengths 20MPa at 28 days.
- Reinforcement is deformed 500 grade.
- Ultimate bearing pressure for footing taken as 300kPa.
- Drainage shall be a layer of suitable granular material with perforated pipe to an open end.
- Compaction forces from machinery are not included in the design.

	$\gamma$ kN/m <sup>3</sup>	$\phi$
7. Soil A includes • Dense Gravel	19.6	30
Soil B includes • Loose Gravel	16.7	30
• Gravely Sand	16.7	35
• Pumice Soil	12.7	35
Soil C includes • Weak Clay	16.7	25

Vertical and Footing Reinforcement "V"	SOIL A		SOIL B		SOIL C	
	Maximum height "H"		Maximum height "H"		Maximum height "H"	
	"L"	"K"	"L"	"K"	"L"	"K"
HD10-600	1000		1000		1000	
	400	100	400	100	700	100
HD10-600	1350		1450		1100	
	550	100	550	100	750	100
HD10-400	1550		1600		1250	
	600	100	600	100	850	100
HD12-600	1500		1600		1250	
	600	150	600	150	850	150
HD12-400	1700		1800		1400	
	700	150	700	150	950	150

## DESIGN DIMENSIONS

# TYPE II. 140mm RETAINING WALL – WITH SURCHARGE

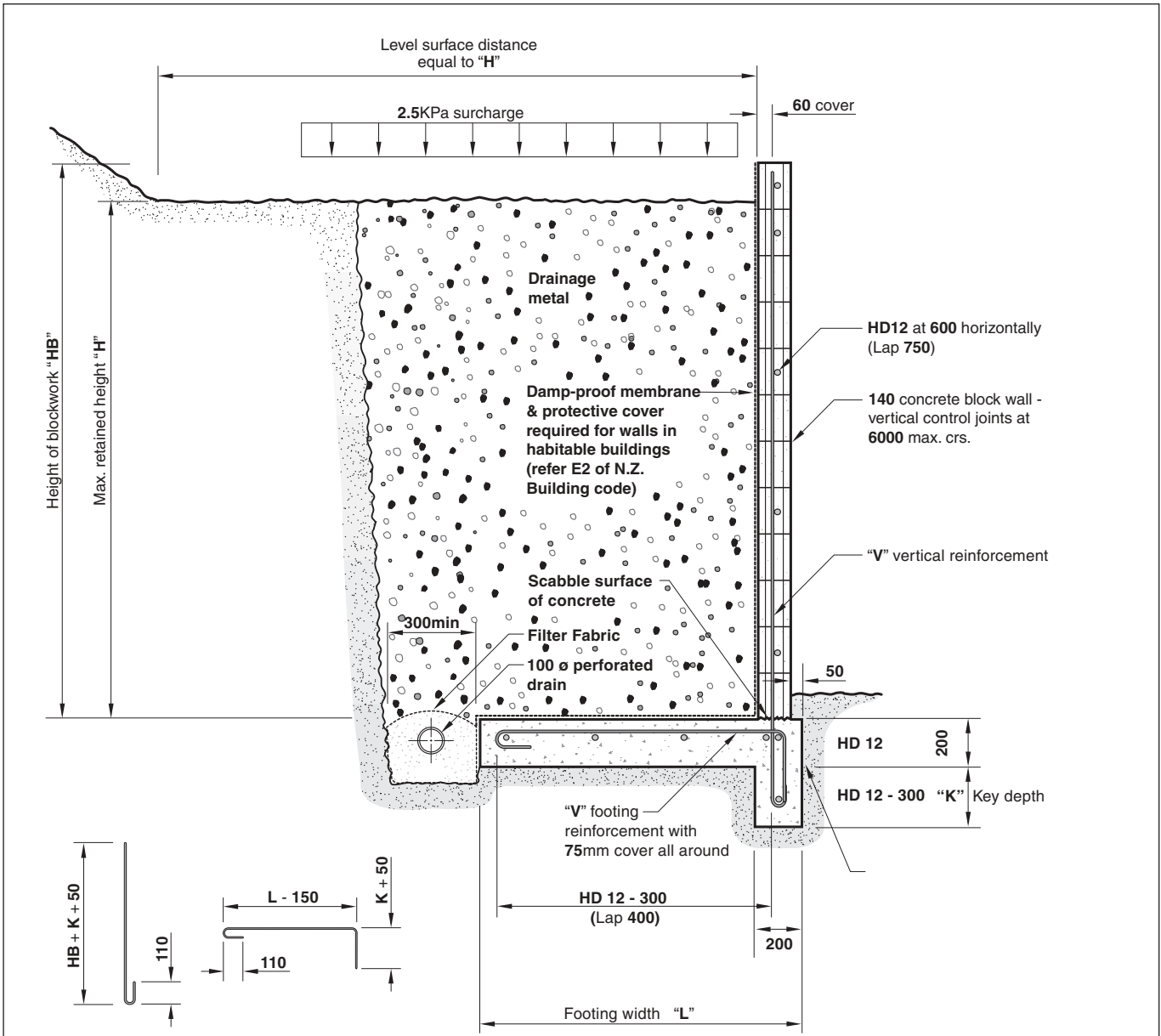

## BAR BENDING DIMENSIONS

## CROSS-SECTION OF RETAINING WALL

### NOTES

- Masonry designed to NZS4230 PART 1.
- Concrete foundation and grout infill strengths 20MPa at 28 days.
- Reinforcement is deformed 500 grade.
- Ultimate bearing pressure for footing taken as 300kPa.
- Drainage shall be a layer of suitable granular material with perforated pipe to an open end.
- Compaction forces from machinery are not included in the design.

	$\gamma$ kN/m <sup>3</sup>	$\phi$
7. Soil A includes	Dense Gravel	19.6 30
Soil B includes	Loose Gravel	16.7 30
	Gravelly Sand	16.7 35
	Pumice Soil	12.7 35
Soil C includes	Weak Clay	16.7 25

Vertical and Footing Reinforcement "V"	SOIL A		SOIL B		SOIL C	
	Maximum height "H"		Maximum height "H"		Maximum height "H"	
	"L"	"K"	"L"	"K"	"L"	"K"
HD10-600	1000		1000		1000	
	450	100	450	100	700	100
HD10-600	1250		1300		1000	
	550	100	550	100	700	100
HD10-400	1400		1500		1150	
	600	100	650	100	800	100
HD12-600	1400		1500		1150	
	600	150	650	150	800	150
HD12-400	1600		1700		1300	
	700	150	700	150	900	150

## DESIGN DIMENSIONS

# TYPE II. 140mm RETAINING WALL – WITH BACKSLOPE

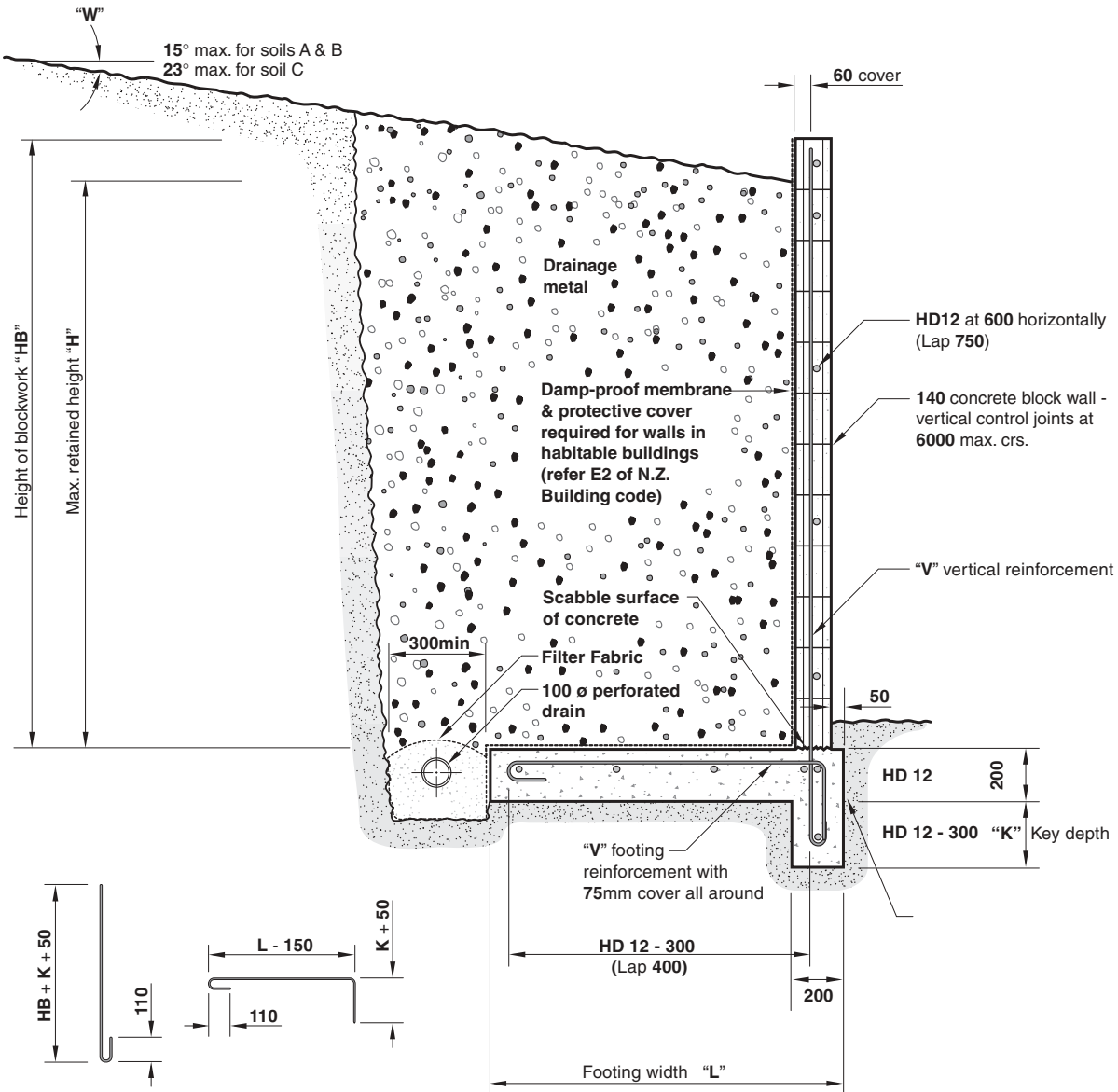

## BAR BENDING DIMENSIONS

## CROSS-SECTION OF RETAINING WALL

### NOTES

- Masonry designed to NZS4230 PART 1.
- Concrete foundation and grout fill strengths 20MPa at 28 days.
- Reinforcement is deformed 500 grade.
- Ultimate bearing pressure for footing taken as 300kPa.
- Drainage shall be a layer of suitable granular material with perforated pipe to an open end.
- Compaction forces from machinery are not included in the design.

	$\gamma$ kN/m <sup>3</sup>	$\phi$
7. Soil A includes	• Dense Gravel	19.6 30
Soil B includes	• Loose Gravel	16.7 30
	• Gravely Sand	16.7 35
	• Pumice Soil	12.7 35
Soil C includes	• Weak Clay	16.7 25

Vertical and Footing Reinforcement "V"	SOIL A		SOIL B		SOIL C	
	Maximum height "H"		Maximum height "H"		Maximum height "H"	
	"L"	"K"	"L"	"K"	"L"	"K"
HD10-600	1000		1000		1000	
	450	100	450	100	700	100
HD10-600	1250		1300		1000	
	550	100	550	100	700	100
HD10-400	1400		1500		1150	
	600	100	650	100	800	100
HD12-600	1400		1500		1150	
	600	150	650	150	800	150
HD12-400	1600		1700		1300	
	700	150	700	150	900	150

## DESIGN DIMENSIONS

# TYPE I. 190mm RETAINING WALL – WITHOUT SURCHARGE

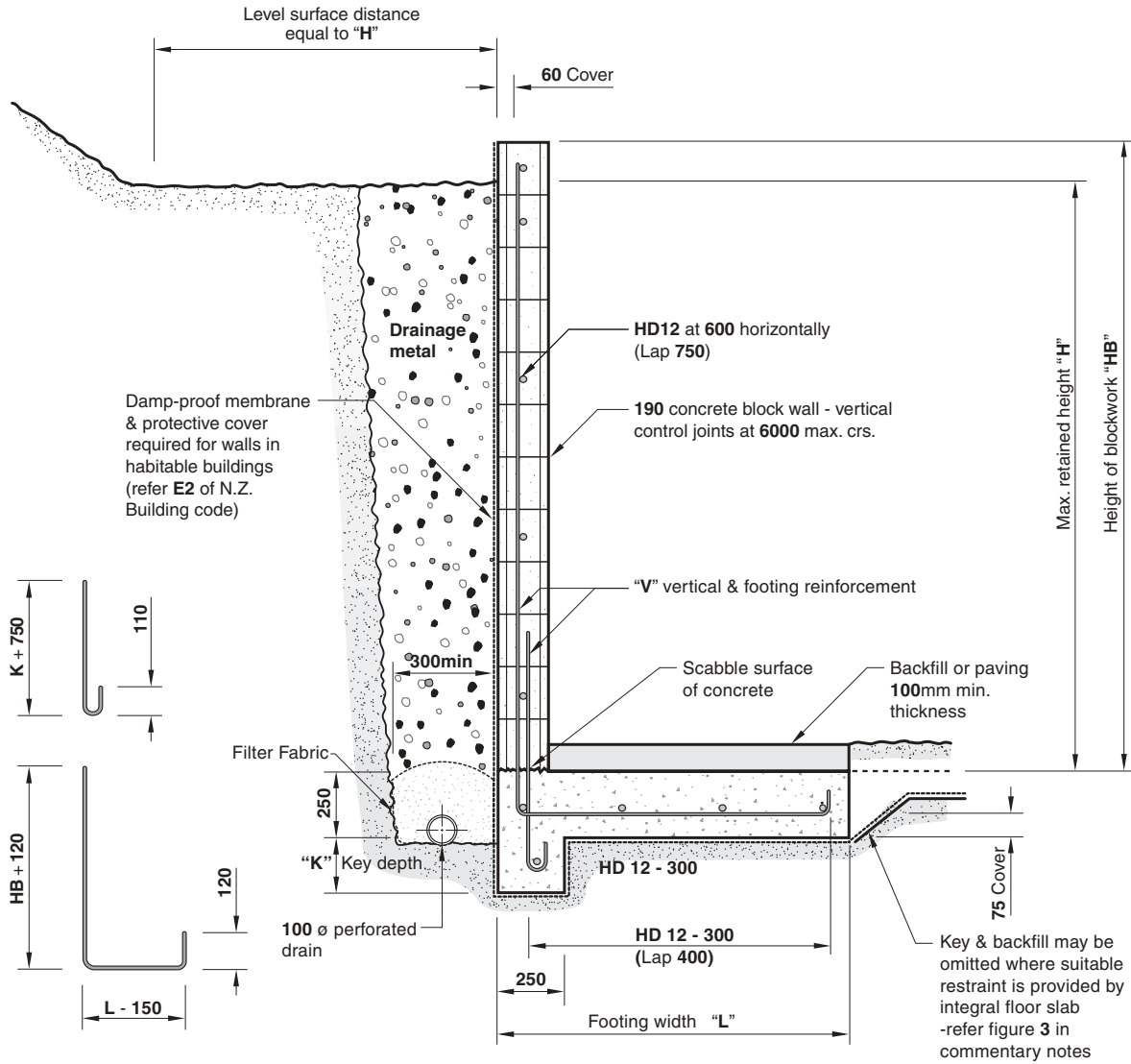

## BAR BENDING DIMENSIONS

## CROSS-SECTION OF RETAINING WALL

### NOTES

- Masonry designed to NZS4230 PART 1.
- Concrete foundation and grout infill strengths 20MPa at 28 days.
- Reinforcement is deformed 500 grade.
- Ultimate bearing pressure for footing taken as 300kPa.
- Drainage shall be a layer of suitable granular material with perforated pipe to an open end.
- Compaction forces from machinery are not included in the design.

	$\gamma$ kN/m <sup>3</sup>	$\phi$
7. Soil A includes • Dense Gravel	19.6	30
Soil B includes • Loose Gravel	16.7	30
• Gravely Sand	16.7	35
• Pumice Soil	12.7	35
Soil C includes • Weak Clay	16.7	25

Vertical and Footing Reinforcement "V"	SOIL A		SOIL B		SOIL C	
	Maximum height "H"		Maximum height "H"		Maximum height "H"	
	"L"	"K"	"L"	"K"	"L"	"K"
HD10-400	1200		1200		1200	
	600	150	550	100	1000	250
HD10-400	1800		1900		1500	
	900	300	900	300	1350	350
HD12-600	1800		1900		1500	
	900	300	900	300	1350	350
HD12-400	2050		2150		1700	
	1100	400	1050	350	1550	400
HD16-600	2150		2250		1750	
	1150	400	1100	400	1600	450
HD16-400	2400		2550		2000	
	1300	450	1300	450	1950	500

## DESIGN DIMENSIONS



# TYPE I. 190mm RETAINING WALL – WITH SURCHARGE

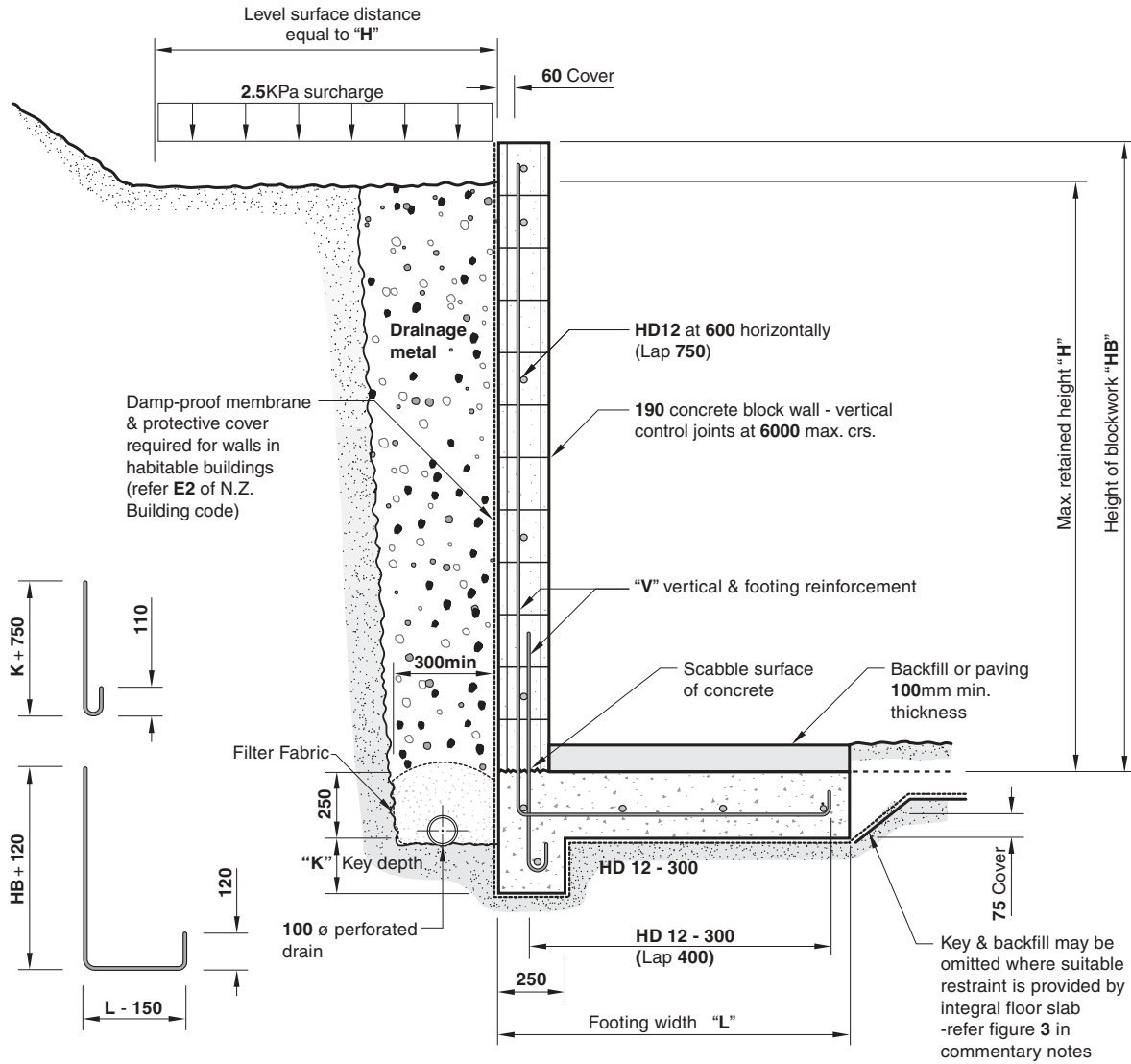

## BAR BENDING DIMENSIONS

### NOTES

- Masonry designed to NZS4230 PART 1.
- Concrete foundation and grout infill strengths 20MPa at 28 days.
- Reinforcement is deformed 500 grade.
- Ultimate bearing pressure for footing taken as 300kPa.
- Drainage shall be a layer of suitable granular material with perforated pipe to an open end.
- Compaction forces from machinery are not included in the design.

	$\gamma$ kN/m <sup>3</sup>	$\phi$
7. Soil A includes • Dense Gravel	19.6	30
Soil B includes • Loose Gravel	16.7	30
• Gravely Sand	16.7	35
• Pumice Soil	12.7	35
Soil C includes • Weak Clay	16.7	25

## CROSS-SECTION OF RETAINING WALL

Vertical and Footing Reinforcement "V"	SOIL A		SOIL B		SOIL C	
	Maximum height "H"		Maximum height "H"		Maximum height "H"	
	"L"	"K"	"L"	"K"	"L"	"K"
HD10-400	1200		1200		1200	
	650	150	650	150	1100	300
HD10-400	1700		1800		1400	
	950	300	950	300	1300	350
HD12-600	1700		1750		1400	
	950	300	950	300	1300	350
HD12-400	1900		2000		1600	
	1100	350	1100	350	1500	400
HD16-600	2000		2100		1700	
	1150	400	1150	400	1650	450
HD16-400	2300		2400		1900	
	1350	450	1350	450	1900	500

## DESIGN DIMENSIONS

# TYPE I. 190mm RETAINING WALL – WITH BACKSLOPE

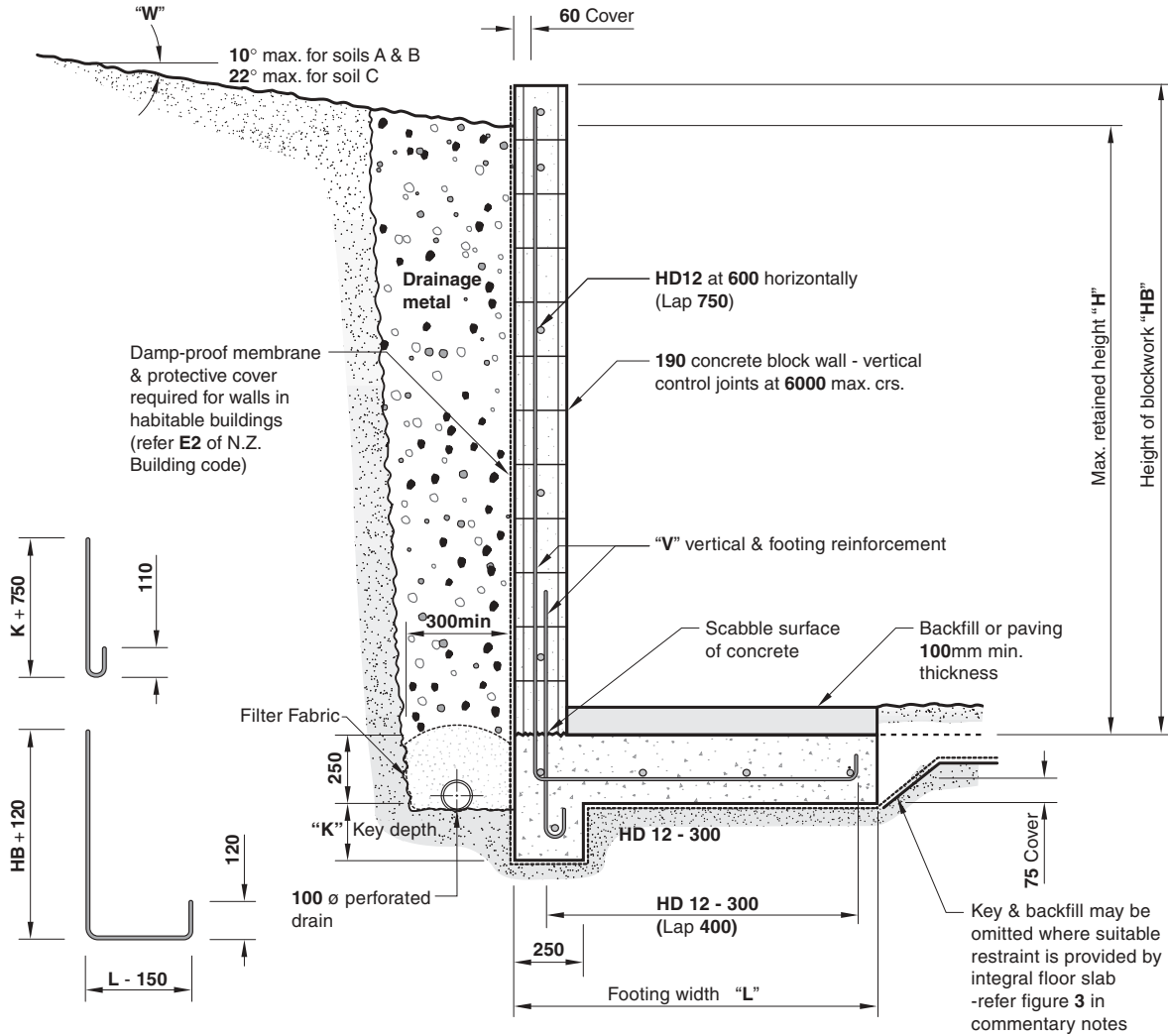

## BAR BENDING DIMENSIONS

## CROSS-SECTION OF RETAINING WALL

### NOTES

- Masonry designed to NZS4230 PART 1.
- Concrete foundation and grout infill strengths 20MPa at 28 days.
- Reinforcement is deformed 500 grade.
- Ultimate bearing pressure for footing taken as 300kPa.
- Drainage shall be a layer of suitable granular material with perforated pipe to an open end.
- Compaction forces from machinery are not included in the design.

	$\gamma$ kN/m <sup>3</sup>	$\phi$
Soil A includes • Dense Gravel	19.6	30
Soil B includes • Loose Gravel	16.7	30
• Gravely Sand	16.7	35
• Pumice Soil	12.7	35
Soil C includes • Weak Clay	16.7	25

Vertical and Footing Reinforcement "V"	SOIL A		SOIL B		SOIL C	
	Maximum height "H"		Maximum height "H"		Maximum height "H"	
	"L"	"K"	"L"	"K"	"L"	"K"
HD10-400	1200		1200		1200	
	650	150	650	150	1100	300
HD10-400	1700		1800		1400	
	950	300	950	300	1300	350
HD12-600	1700		1750		1400	
	950	300	950	300	1300	350
HD12-400	1900		2000		1600	
	1100	350	1100	350	1500	400
HD16-600	2000		2100		1700	
	1150	400	1150	400	1650	450
HD16-400	2300		2400		1900	
	1350	450	1350	450	1900	500

## DESIGN DIMENSIONS

# TYPE II. 190mm RETAINING WALL – WITHOUT SURCHARGE

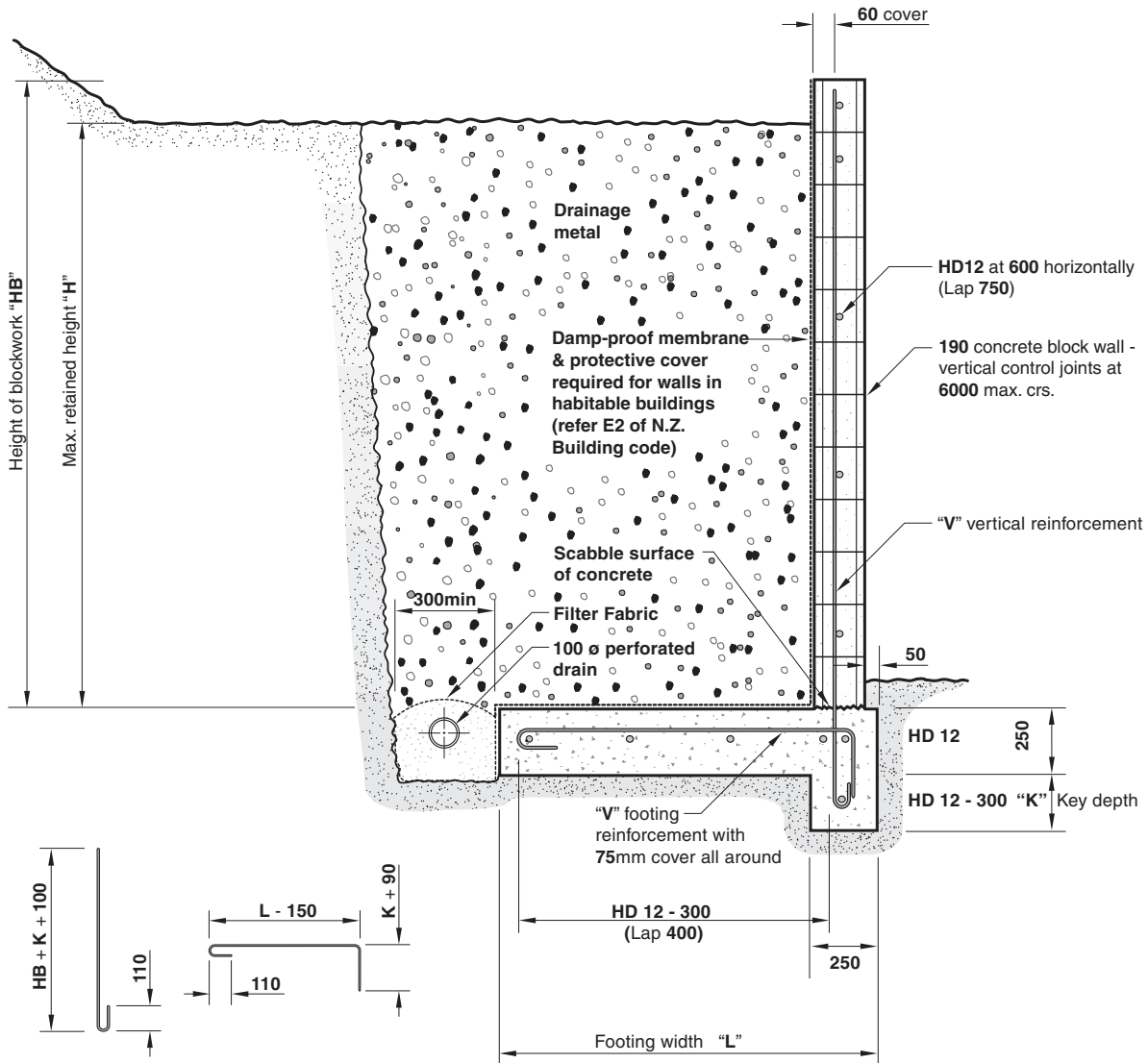

## BAR BENDING DIMENSIONS

## CROSS-SECTION OF RETAINING WALL

### NOTES

- Masonry designed to NZS4230 PART 1.
- Concrete foundation and grout infill strengths 20MPa at 28 days.
- Reinforcement is deformed 500 grade.
- Ultimate bearing pressure for footing taken as 300kPa.
- Drainage shall be a layer of suitable granular material with perforated pipe to an open end.
- Compaction forces from machinery are not included in the design.

	$\gamma$ kN/m <sup>3</sup>	$\phi$
7. Soil A includes • Dense Gravel	19.6	30
Soil B includes • Loose Gravel	16.7	30
• Gravely Sand	16.7	35
• Pumice Soil	12.7	35
Soil C includes • Weak Clay	16.7	25

Vertical and Footing Reinforcement "V"	SOIL A		SOIL B		SOIL C	
	Maximum height "H"		Maximum height "H"		Maximum height "H"	
	"L"	"K"	"L"	"K"	"L"	"K"
HD10-400	1200		1200		1200	
	500	100	500	100	850	100
HD10-400	1850		1950		1500	
	750	100	800	100	1050	100
HD12-600	1850		1950		1500	
	750	100	800	100	1050	100
HD12-400	2100		2200		1700	
	850	100	900	100	1200	100
HD16-600	2200		2300		1750	
	900	150	950	150	1200	150
HD16-400	2500		2600		2000	
	1050	150	1050	150	1400	200

## DESIGN DIMENSIONS

# TYPE II. 190mm RETAINING WALL – WITH SURCHARGE

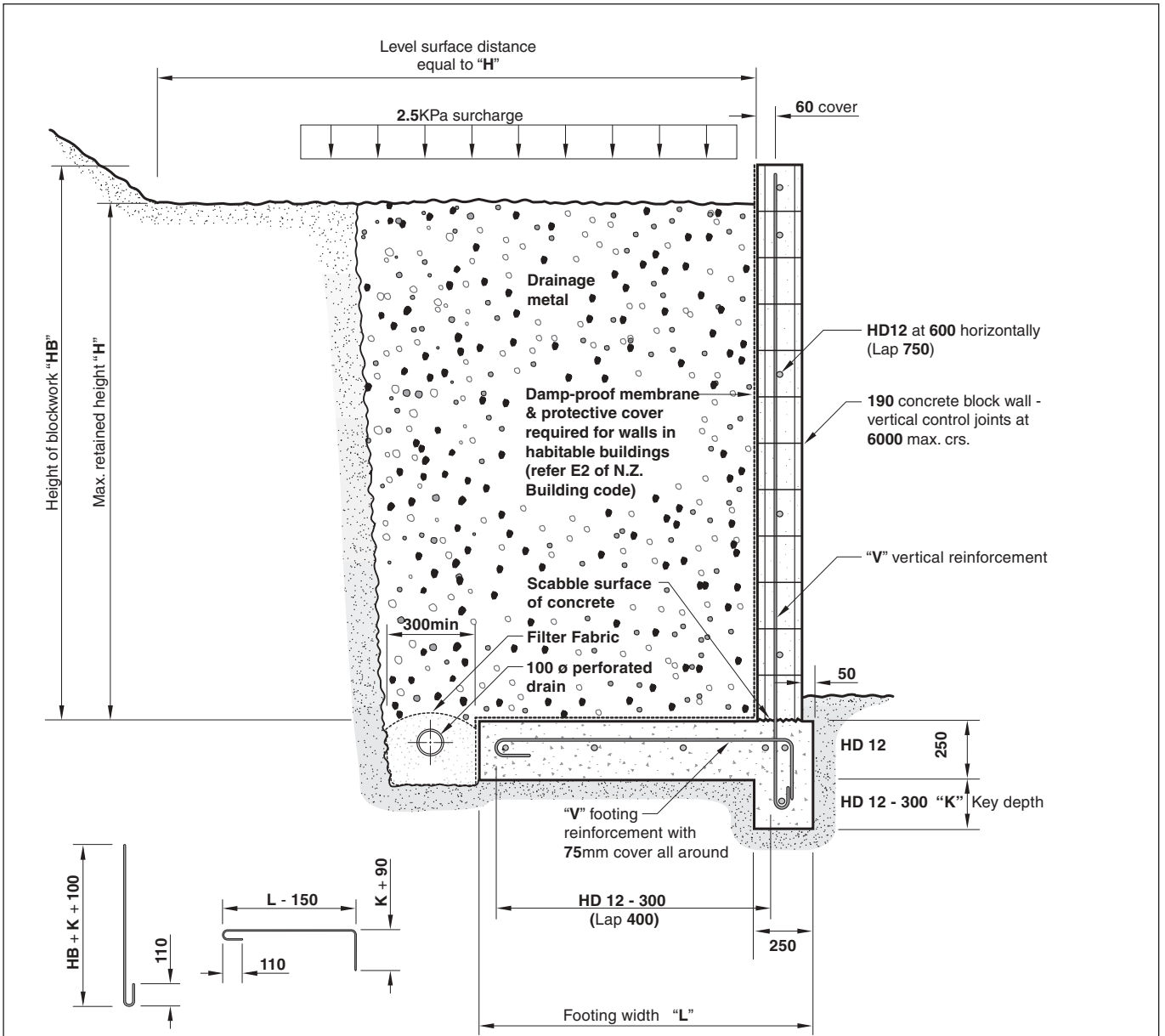

## BAR BENDING DIMENSIONS

## CROSS-SECTION OF RETAINING WALL

### NOTES

- Masonry designed to NZS4230 PART 1.
- Concrete foundation and grout infill strengths 20MPa at 28 days.
- Reinforcement is deformed 500 grade.
- Ultimate bearing pressure for footing taken as 300kPa.
- Drainage shall be a layer of suitable granular material with perforated pipe to an open end.
- Compaction forces from machinery are not included in the design.

	$\gamma$ kN/m <sup>3</sup>	$\phi$
7. Soil A includes	• Dense Gravel	19.6 30
Soil B includes	• Loose Gravel	16.7 30
	• Gravely Sand	16.7 35
	• Pumice Soil	12.7 35
Soil C includes	• Weak Clay	16.7 25

Vertical and Footing Reinforcement "V"	SOIL A		SOIL B		SOIL C	
	Maximum height "H"		Maximum height "H"		Maximum height "H"	
	"L"	"K"	"L"	"K"	"L"	"K"
HD10-400	1200		1200		1200	
	550	100	550	100	850	100
HD10-400	1750		1850		1400	
	750	100	750	100	1000	150
HD12-600	1750		1800		1400	
	750	100	750	100	1000	150
HD12-400	2000		2050		1600	
	900	100	900	100	1100	150
HD16-600	2100		2200		1700	
	900	150	950	150	1200	150
HD16-400	2350		2450		1900	
	1050	150	1050	150	1300	200

## DESIGN DIMENSIONS

# TYPE II. 190mm RETAINING WALL – WITH BACKSLOPE

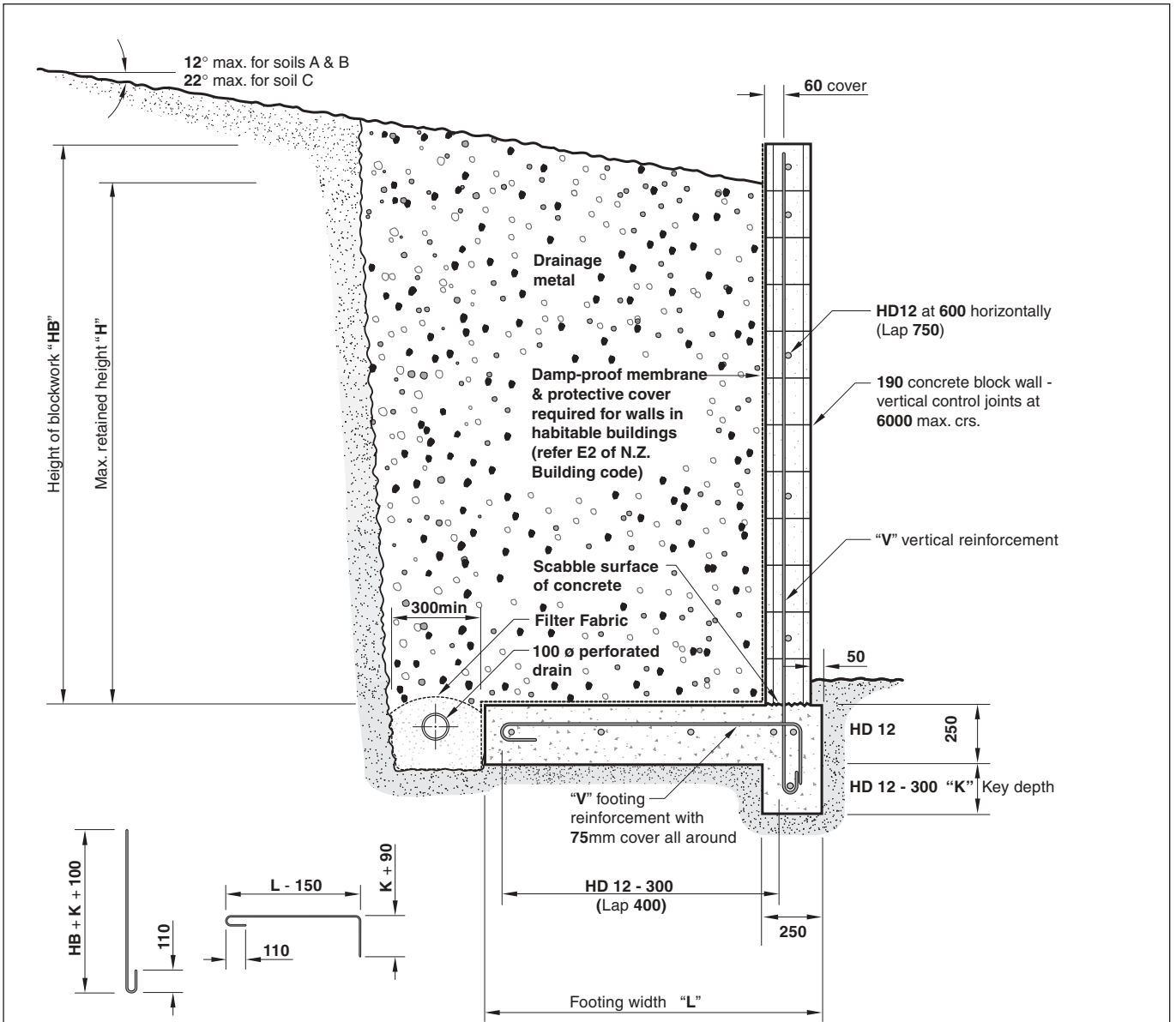

## BAR BENDING DIMENSIONS

## CROSS-SECTION OF RETAINING WALL

### NOTES

- Masonry designed to NZS4230 PART 1.
- Concrete foundation and grout infill strengths 20MPa at 28 days.
- Reinforcement is deformed 500 grade.
- Ultimate bearing pressure for footing taken as 300kPa.
- Drainage shall be a layer of suitable granular material with perforated pipe to an open end.
- Compaction forces from machinery are not included in the design.

	$\gamma$ kN/m <sup>3</sup>	$\phi$
7. Soil A includes • Dense Gravel	19.6	30
Soil B includes • Loose Gravel	16.7	30
• Gravely Sand	16.7	35
• Pumice Soil	12.7	35
Soil C includes • Weak Clay	16.7	25

Vertical and Footing Reinforcement "V"	SOIL A		SOIL B		SOIL C	
	Maximum height "H"		Maximum height "H"		Maximum height "H"	
	"L"	"K"	"L"	"K"	"L"	"K"
HD10-400	1200		1200		1200	
	550	100	550	100	850	100
HD10-400	1750		1850		1400	
	750	100	750	100	1000	150
HD12-600	1750		1800		1400	
	750	100	750	100	1000	150
HD12-400	2000		2050		1600	
	900	100	900	100	1100	150
HD16-600	2100		2200		1700	
	900	150	950	150	1200	150
HD16-400	2350		2450		1900	
	1050	150	1050	150	1300	200

## DESIGN DIMENSIONS

# TYPE I. 240mm RETAINING WALL – WITHOUT SURCHARGE

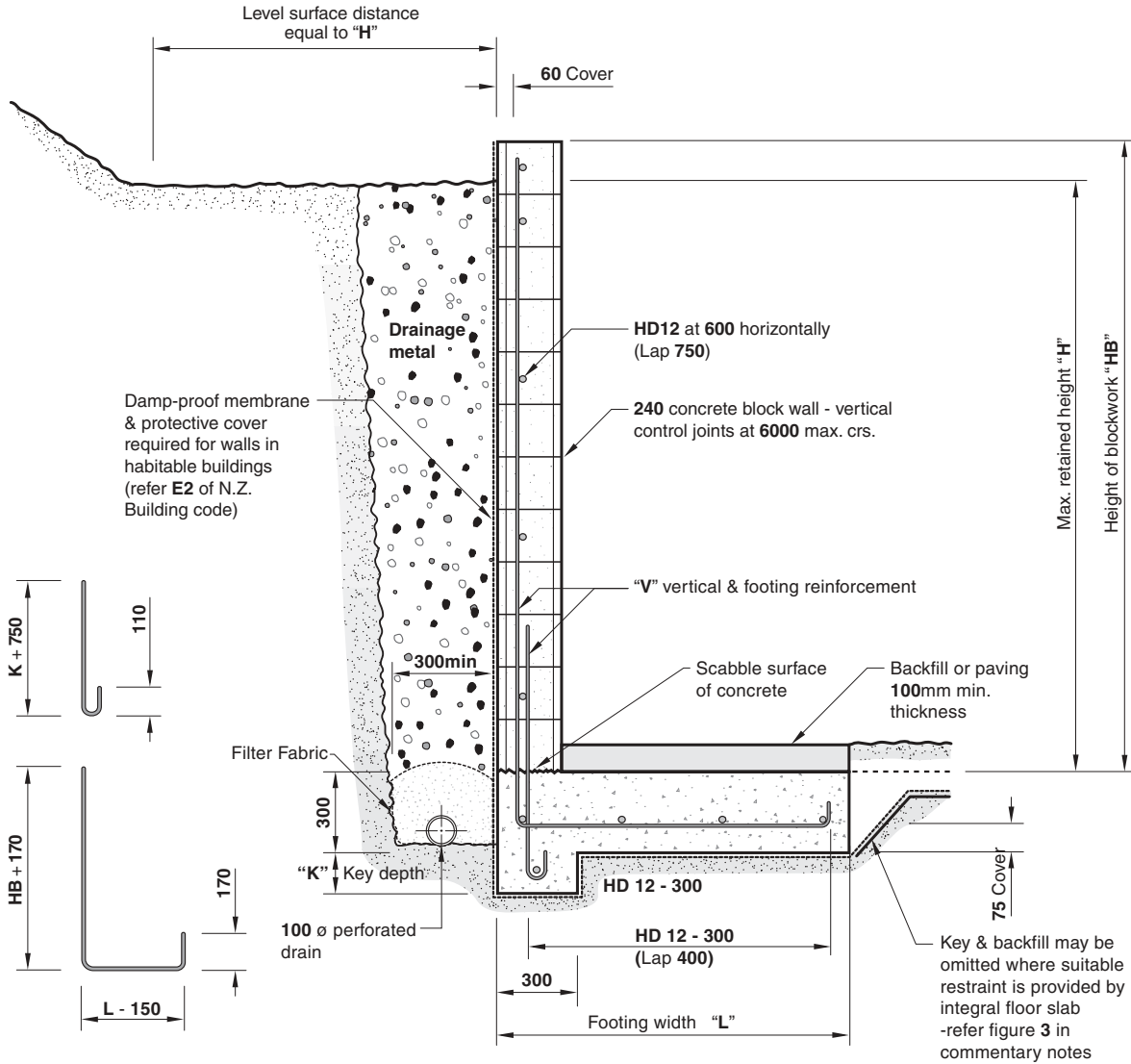

## BAR BENDING DIMENSIONS

## CROSS-SECTION OF RETAINING WALL

### NOTES

- Masonry designed to NZS4230 PART 1.
- Concrete foundation and grout infill strengths 20MPa at 28 days.
- Reinforcement is deformed 500 grade.
- Ultimate bearing pressure for footing taken as 300kPa.
- Drainage shall be a layer of suitable granular material with perforated pipe to an open end.
- Compaction forces from machinery are not included in the design.

	$\gamma$ kN/m <sup>3</sup>	$\phi$
7. Soil A includes • Dense Gravel	19.6	30
Soil B includes • Loose Gravel	16.7	30
• Gravely Sand	16.7	35
• Pumice Soil	12.7	35
Soil C includes • Weak Clay	16.7	25

Vertical and Footing Reinforcement "V"	SOIL A		SOIL B		SOIL C	
	Maximum height "H"		Maximum height "H"		Maximum height "H"	
	"L"	"K"	"L"	"K"	"L"	"K"
HD12-400	2300		2450		1900	
	1200	400	1200	400	1700	450
HD16-600	2450		2550		2000	
	1300	400	1250	450	1800	500
HD16-400	2750		2900		2250	
	1500	500	1500	500	2100	550
HD20-600	2800		2950		2300	
	1500	500	1500	550	2200	550
HD20-400	3100		3300		2550	
	1750	600	1750	600	2500	650

## DESIGN DIMENSIONS



# TYPE I. 240mm RETAINING WALL – WITH SURCHARGE

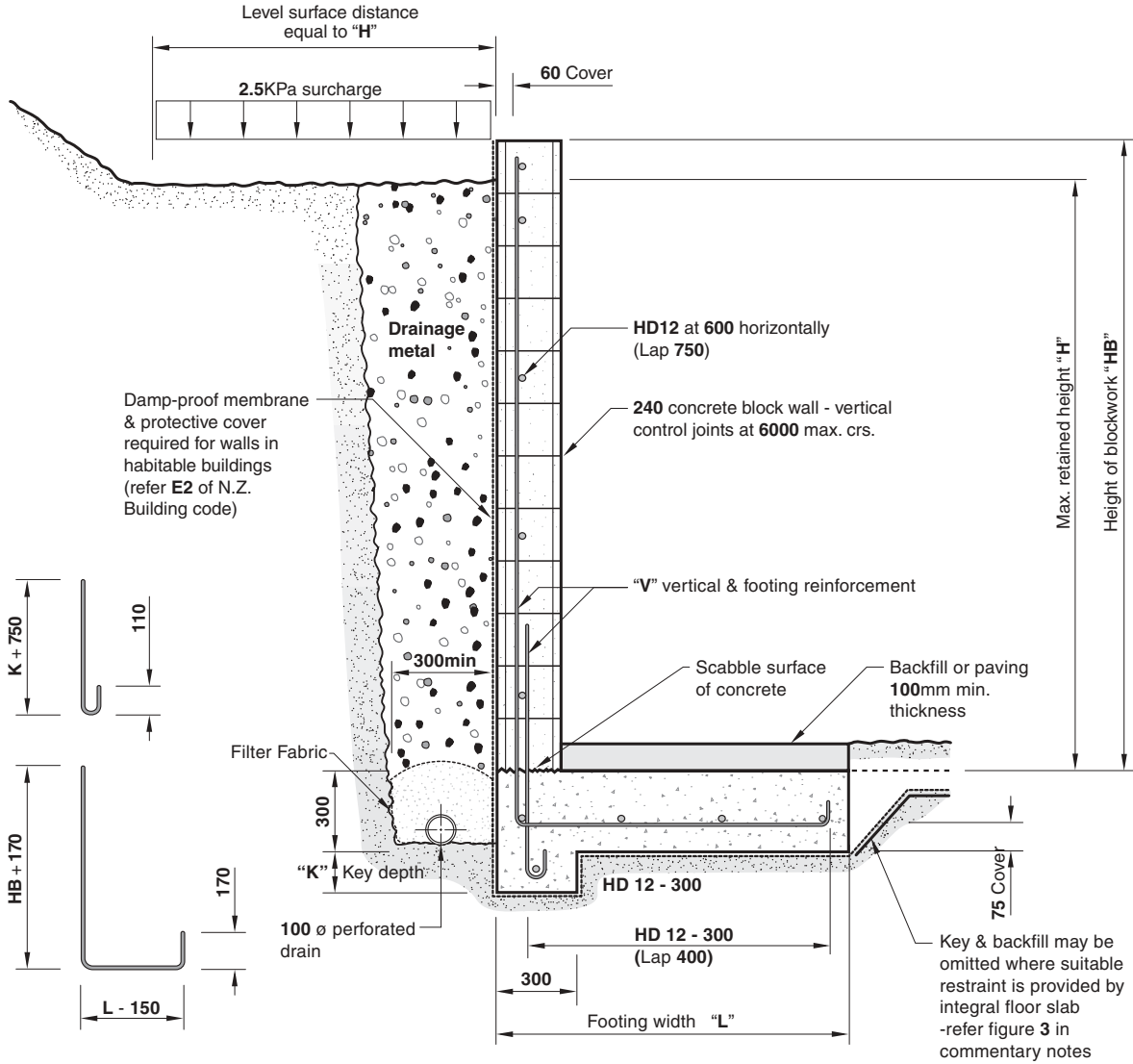

## BAR BENDING DIMENSIONS

### NOTES

- Masonry designed to NZS4230 PART 1.
- Concrete foundation and grout infill strengths 20MPa at 28 days.
- Reinforcement is deformed 500 grade.
- Ultimate bearing pressure for footing taken as 300kPa.
- Drainage shall be a layer of suitable granular material with perforated pipe to an open end.
- Compaction forces from machinery are not included in the design.

	$\gamma$ kN/m <sup>3</sup>	$\phi$
Soil A includes • Dense Gravel	19.6	30
Soil B includes • Loose Gravel	16.7	30
• Gravely Sand	16.7	35
• Pumice Soil	12.7	35
Soil C includes • Weak Clay	16.7	25

## CROSS-SECTION OF RETAINING WALL

Vertical and Footing Reinforcement "V"	SOIL A		SOIL B		SOIL C	
	Maximum height "H"		Maximum height "H"		Maximum height "H"	
	"L"	"K"	"L"	"K"	"L"	"K"
HD12-400	2200		2300		1800	
	1200	400	1200	400	1650	500
HD16-600	2300		2400		1900	
	1300	400	1250	450	1800	500
HD16-400	2650		2750		2200	
	1500	500	1500	500	2150	600
HD20-600	2650		2800		2200	
	1500	500	1500	550	2150	600
HD20-400	3000		3150		2500	
	1750	600	1750	600	2550	650

## DESIGN DIMENSIONS

# TYPE I. 240mm RETAINING WALL – WITH BACKSLOPE

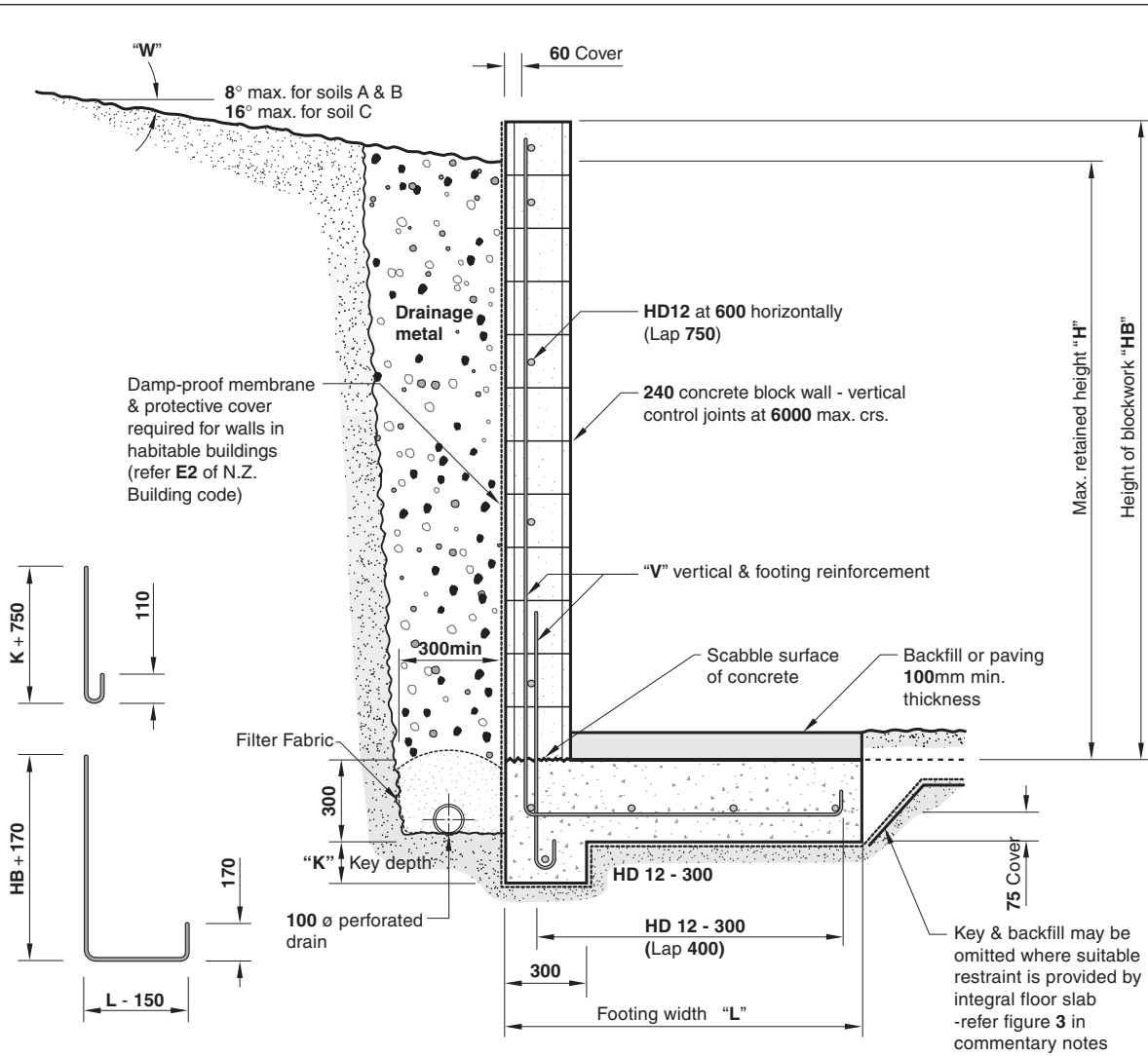

## BAR BENDING DIMENSIONS

## CROSS-SECTION OF RETAINING WALL

### NOTES

- Masonry designed to NZS4230 PART 1.
- Concrete foundation and grout infill strengths 20MPa at 28 days.
- Reinforcement is deformed 500 grade.
- Ultimate bearing pressure for footing taken as 300kPa.
- Drainage shall be a layer of suitable granular material with perforated pipe to an open end.
- Compaction forces from machinery are not included in the design.

	$\gamma$ kN/m <sup>3</sup>	$\phi$
7. Soil A includes		
• Dense Gravel	19.6	30
Soil B includes		
• Loose Gravel	16.7	30
• Gravely Sand	16.7	35
• Pumice Soil	12.7	35
Soil C includes		
• Weak Clay	16.7	25

Vertical and Footing Reinforcement "V"	SOIL A		SOIL B		SOIL C	
	Maximum height "H"		Maximum height "H"		Maximum height "H"	
	"L"	"K"	"L"	"K"	"L"	"K"
HD12-400	2200		2300		1800	
	1200	400	1200	400	1650	500
HD16-600	2300		2400		1900	
	1300	400	1250	450	1800	500
HD16-400	2650		2750		2200	
	1500	500	1500	500	2150	600
HD20-600	2650		2800		2200	
	1500	500	1500	550	2150	600
HD20-400	3000		3150		2500	
	1750	600	1750	600	2550	650

## DESIGN DIMENSIONS

# TYPE II. 240mm RETAINING WALL – WITHOUT SURCHARGE

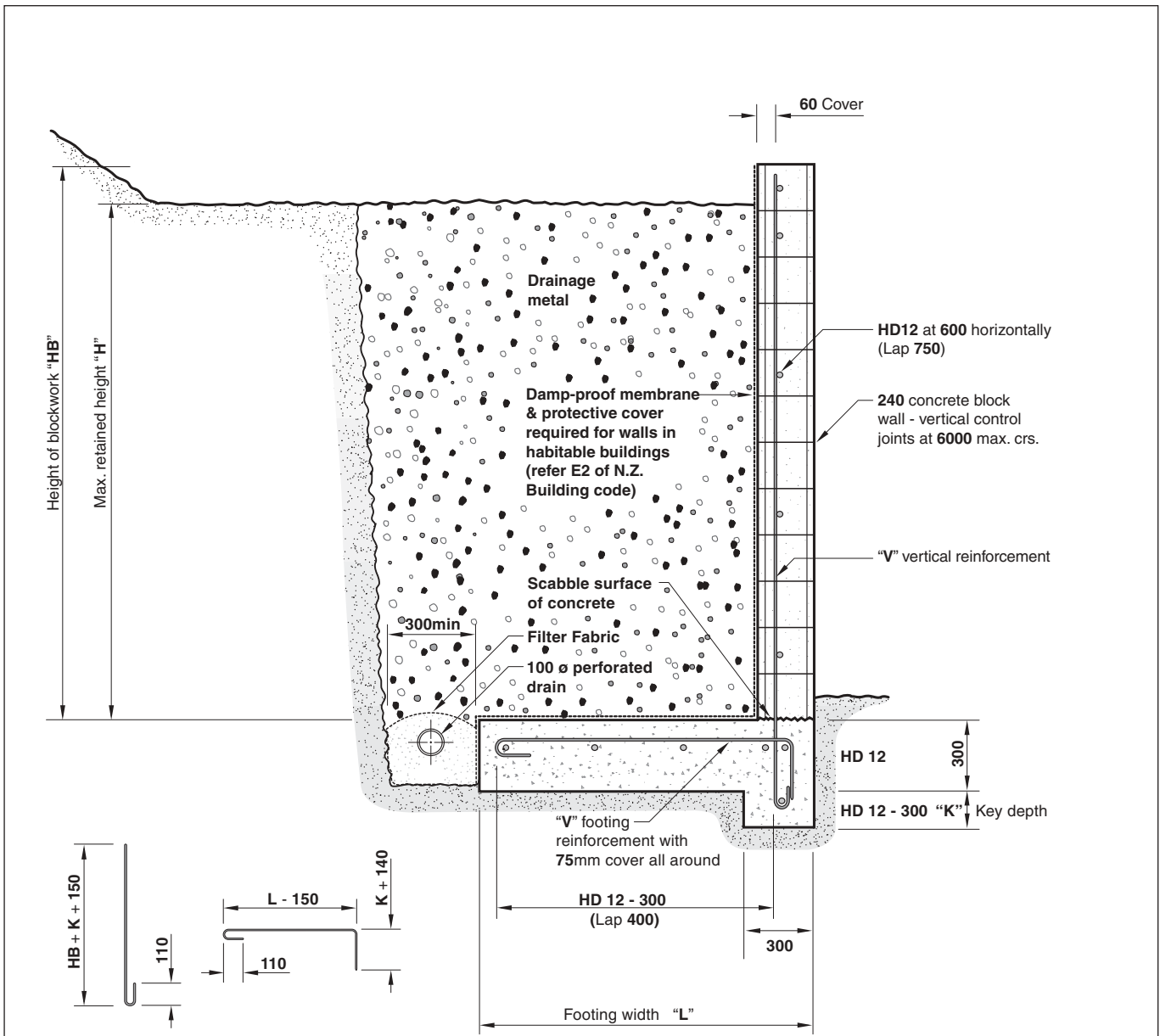

## BAR BENDING DIMENSIONS

## CROSS-SECTION OF RETAINING WALL

### NOTES

- Masonry designed to NZS4230 PART 1.
- Concrete foundation and grout infill strengths 20MPa at 28 days.
- Reinforcement is deformed 500 grade.
- Ultimate bearing pressure for footing taken as 300kPa.
- Drainage shall be a layer of suitable granular material with perforated pipe to an open end.
- Compaction forces from machinery are not included in the design.

$\gamma$  kN/m<sup>3</sup>  $\phi$

- |                    |                |      |    |
|--------------------|----------------|------|----|
| 7. Soil A includes | • Dense Gravel | 19.6 | 30 |
| Soil B includes    | • Loose Gravel | 16.7 | 30 |
|                    | • Gravely Sand | 16.7 | 35 |
|                    | • Pumice Soil  | 12.7 | 35 |
| Soil C includes    | • Weak Clay    | 16.7 | 25 |

Vertical and Footing Reinforcement "V"	SOIL A		SOIL B		SOIL C	
	Maximum height "H"		Maximum height "H"		Maximum height "H"	
	"L"	"K"	"L"	"K"	"L"	"K"
HD12-400	2350		2500		1900	
	1000	100	1050	100	1350	150
HD16-600	2500		2650		2000	
	1100	100	1100	100	1450	150
HD16-400	2800		3000		2300	
	1250	100	1300	100	1650	150
HD20-600	2850		3000		2300	
	1250	200	1300	200	1650	200
HD20-400	3200		3400		2600	
	1500	200	1500	200	1900	200

## DESIGN DIMENSIONS

# TYPE II. 240mm RETAINING WALL – WITH SURCHARGE

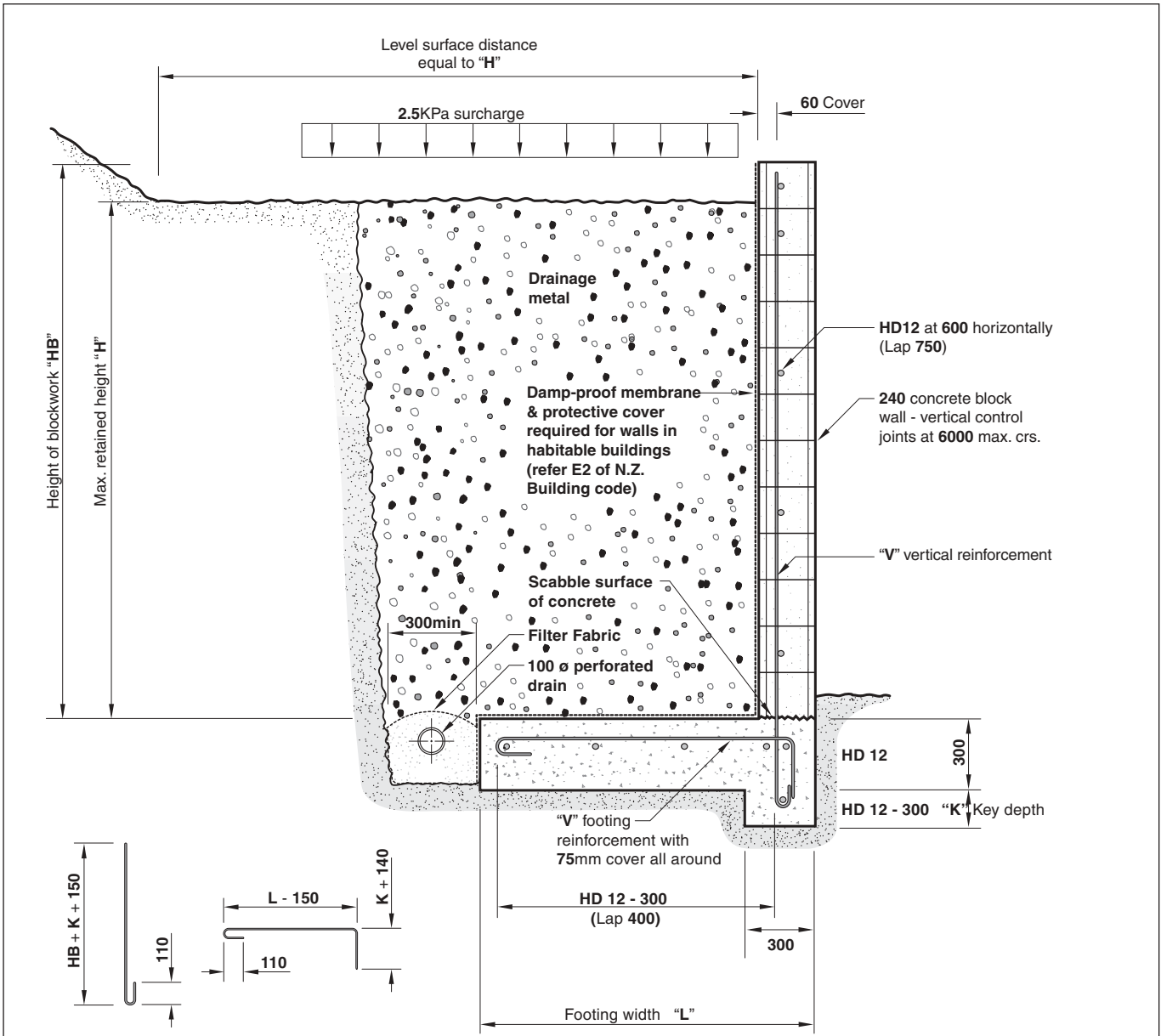

## BAR BENDING DIMENSIONS

### NOTES

- Masonry designed to NZS4230 PART 1.
  - Concrete foundation and grout infill strengths 20MPa at 28 days.
  - Reinforcement is deformed 500 grade.
  - Ultimate bearing pressure for footing taken as 300kPa.
  - Drainage shall be a layer of suitable granular material with perforated pipe to an open end.
  - Compaction forces from machinery are not included in the design.
- |                    |                            |         |
|--------------------|----------------------------|---------|
|                    | $\gamma$ kN/m <sup>3</sup> | $\phi$  |
| 7. Soil A includes | • Dense Gravel             | 19.6 30 |
| Soil B includes    | • Loose Gravel             | 16.7 30 |
|                    | • Gravely Sand             | 16.7 35 |
|                    | • Pumice Soil              | 12.7 35 |
| Soil C includes    | • Weak Clay                | 16.7 25 |

## CROSS-SECTION OF RETAINING WALL

Vertical and Footing Reinforcement "V"	SOIL A		SOIL B		SOIL C	
	Maximum height "H"		Maximum height "H"		Maximum height "H"	
	"L"	"K"	"L"	"K"	"L"	"K"
HD12-400	2250		2350		1850	
	1000	100	1050	100	1350	150
HD16-600	2350		2500		1950	
	1050	100	1100	100	1400	150
HD16-400	2700		2850		2200	
	1250	100	1300	100	1600	150
HD20-600	2750		2850		2200	
	1300	200	1300	200	1600	200
HD20-400	3100		3250		2500	
	1500	200	1500	200	1850	200

## DESIGN DIMENSIONS

# TYPE II. 240mm RETAINING WALL – WITH BACKSLOPE

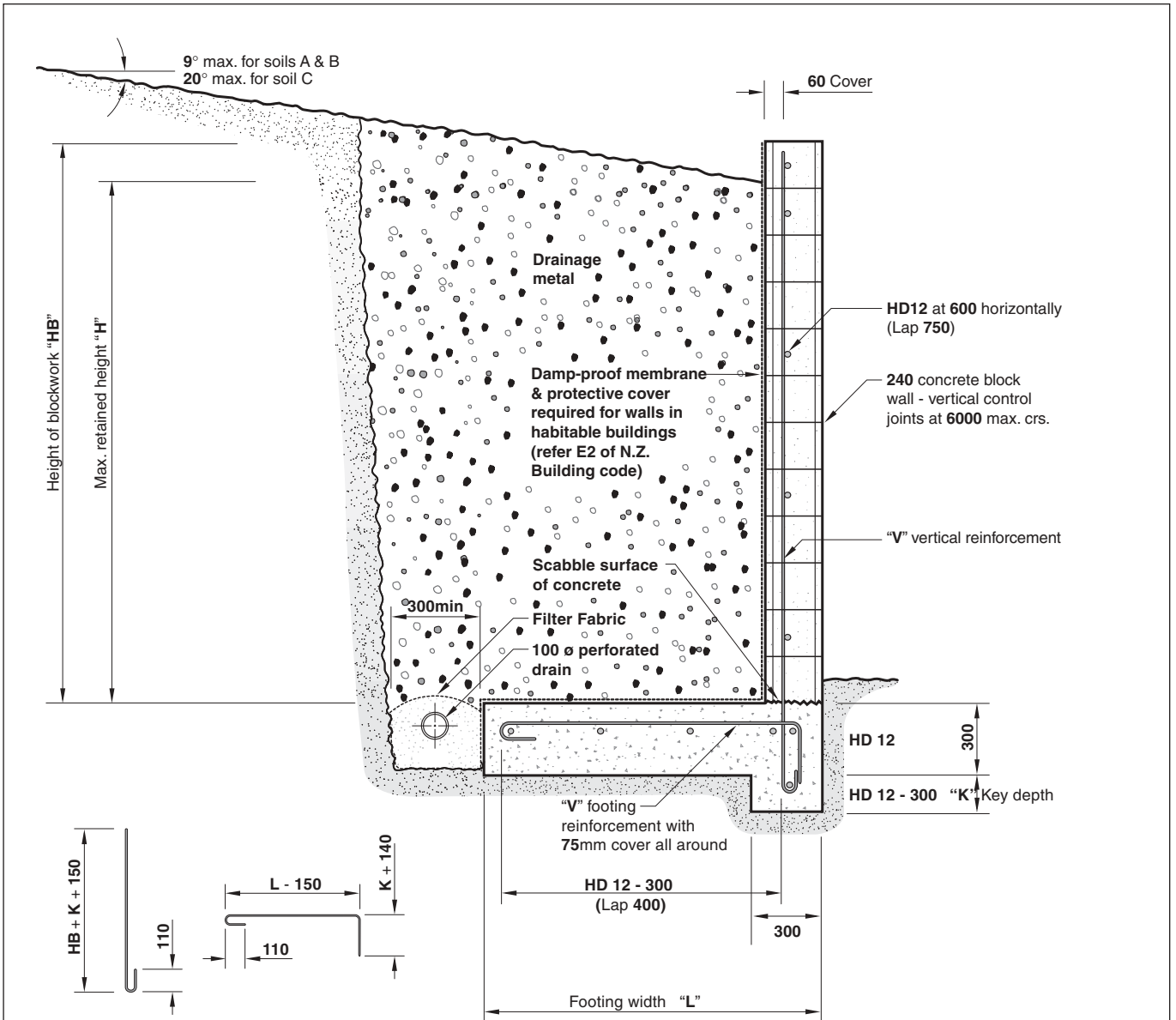

## BAR BENDING DIMENSIONS

### NOTES

- Masonry designed to NZS4230 PART 1.
- Concrete foundation and grout fill strengths 20MPa at 28 days.
- Reinforcement is deformed 500 grade.
- Ultimate bearing pressure for footing taken as 300kPa.
- Drainage shall be a layer of suitable granular material with perforated pipe to an open end.
- Compaction forces from machinery are not included in the design.

	$\gamma$ kN/m <sup>3</sup>	$\phi$
7. Soil A includes • Dense Gravel	19.6	30
Soil B includes • Loose Gravel	16.7	30
• Gravely Sand	16.7	35
• Pumice Soil	12.7	35
Soil C includes • Weak Clay	16.7	25

## CROSS-SECTION OF RETAINING WALL

Vertical and Footing Reinforcement "V"	SOIL A		SOIL B		SOIL C	
	Maximum height "H"		Maximum height "H"		Maximum height "H"	
	"L"	"K"	"L"	"K"	"L"	"K"
HD12-400	2250		2350		1850	
	1000	100	1050	100	1350	150
HD16-600	2350		2500		1950	
	1050	100	1100	100	1400	150
HD16-400	2700		2850		2200	
	1250	100	1300	100	1600	150
HD20-600	2750		2850		2200	
	1300	200	1300	200	1600	200
HD20-400	3100		3250		2500	
	1500	200	1500	200	1850	200

## DESIGN DIMENSIONS

This publication is based on material prepared through a joint partnership between the New Zealand Concrete Masonry Association and the Cement & Concrete Association of New Zealand.

The information in this publication is provided in good faith for general guidance and is not intended to replace the services of professional consultants on particular projects. No liability can be accepted by Firth Industries or by either Association for its use.





Firth Industries' RibRaft Floor System is accredited by the Building Industry Authority as complying with certain provisions of the New Zealand Building Code. The Authority's accreditation is binding on territorial authorities and building certifiers.



0800 800 576  
[www.firth.co.nz](http://www.firth.co.nz)