



Vertical Installation Technical Specification

Contents

1	APPLICATION AND SCOPE	3	5	INSTALLATION	6
1.1	Application	3	5.1	General	6
1.2	Scope	3	5.2	Fastener durability	6
1.3	Details	3	5.3	Fastener – size and layout	7
1.4	Specific design	3	6	JOINTS	7
2	DESIGN	3	6.1	Vertical joint	7
2.1	Compliance	3	6.2	Horizontal joint	7
2.2	Responsibility	3	6.3	Drainage joint	7
2.3	Site and foundation	3	6.4	External corner	7
2.4	Surface clearances	3	6.5	Internal corner	7
2.5	Moisture management	4	7	FINISHES	8
2.6	Structure	4	7.1	Preparation	8
2.7	Fire rated walls	4	7.2	Painting	8
2.8	Structural bracing	4	7.3	Flexible sealant	8
2.9	Energy efficiency	4	8	STORAGE AND HANDLING	8
3	FRAMING	5	9	MAINTENANCE	8
3.1	General	5	10	PRODUCT INFORMATION	9
3.2	Timber framing	5	10.1	Manufacturing and classification	9
3.3	Special framing requirements	5	10.2	Product mass	9
3.4	Tolerances	5	10.3	Durability	9
4	PREPARATION	5	11	SAFE WORKING PRACTICES	10
4.1	Flexible underlay/HomeRAB Pre-Cladding	5	12	PRODUCT AND ACCESSORIES	12
4.2	RAB Board	5	13	DETAILS	14
4.3	Cavity closure/vent strip	6		PRODUCT WARRANTY	39
4.4	Cavity battens	6			
4.5	Intermediate support	6			
4.6	Flashings	6			
4.7	Junctions and penetrations	6			

WE VALUE YOUR FEEDBACK

To continue with the development of our products and systems, we value your input. Please send any suggestions, including your name, contact details, and relevant sketches to:

Ask James Hardie™

literaturefeedback@jameshardie.co.nz

1 Application and scope

1.1 APPLICATION

Linea™ Oblique™ Weatherboard installed as per this specification gives a vertical rusticated profile weatherboard appearance. Linea Oblique Weatherboard can be fixed to timber-framed external walls. A wide range of colours can be used, varying from light to dark. Linea Oblique Weatherboard is available in 200mm or 300mm wide x 4200mm or 2700mm lengths and is 16mm thick.

Specifiers

If you are a specifier or other responsible party for a project ensure that the information in this document is appropriate for the application you are planning and that you undertake specific design and detailing for areas which fall outside the scope of these specifications.

Installers

If you are an installer ensure that you follow the design, moisture management principles, associated figures and material selection provided by the designer and this James Hardie Technical Specification. All of the details provided in this document must be read in conjunction with the project specification.

Make sure your information is up to date

When specifying or installing James Hardie products, ensure that you have the current manual. Additional installation information, warranties and warnings are available at www.jameshardie.co.nz or Ask James Hardie™ on 0800 808 868.

1.2 SCOPE

This specification covers the installation of Linea Oblique Weatherboard fixed vertically over James Hardie horizontal cavity battens on buildings that fall within the scope limitation of NZS 3604 and E2/AS1 of the New Zealand Building Code (NZBC).

This specification also covers the installation of Linea Oblique Weatherboard on projects, which are subject to specific engineering design (SED) up to a wind pressure of 2.5kPa (ULS).

1.3 DETAILS

Various typical Linea Oblique Weatherboard vertical construction details are provided in the Details section of this document.

These details are available in dwg, dxf, jpg and pdf file format and can be downloaded from our website at www.jameshardie.co.nz.

All dimensions shown are in millimetres unless noted otherwise.

1.4 SPECIFIC DESIGN

For use of Linea Oblique Weatherboard in a specific engineering design (SED) project that is outside the scope of this literature, the designer, architect or engineer must ensure that applicable clauses of the NZBC have been considered and a specific design has been undertaken.

Linea Oblique Weatherboard is suitable for use in SED project up to a wind pressure of 2.5kPa (ULS).

2 Design

2.1 COMPLIANCE

Linea Oblique Weatherboard has been issued a CodeMark certification number GM-CM30059 which confirms Linea Oblique Weatherboard is deemed to comply with the requirements of the NZBC. Please refer to our website www.jameshardie.co.nz for a copy of the CodeMark certificate. Linea Oblique Weatherboard has been appraised by BRANZ as an alternative solution and found to meet the required provisions of the NZBC when installed in accordance with this Linea Oblique Weatherboard Vertical Installation technical specification. BRANZ Appraisal number 897 (2015) at www.branz.co.nz or www.jameshardie.co.nz.



2.2 RESPONSIBILITY

The specifier or other party responsible for the project must ensure that the information and details in this specification are appropriate for the intended application and that additional detailing is performed for specific design or any areas that fall outside the scope of this technical specification. For applications outside the scope of this literature and details, which are not provided herein, the architect, designer or engineer must undertake specific design and it should be ensured that the intent of their design meets the requirements of the NZBC.

All New Zealand Standards referenced in this document are current editions and must be complied with.

James Hardie conducts stringent quality checks to ensure that any product manufactured falls within our quality spectrum. It is the responsibility of the builder to ensure that the product meets aesthetic requirements before installation. James Hardie will not be responsible for rectifying obvious aesthetic surface variations following installation.

2.3 SITE AND FOUNDATION

The site on which the building is situated must comply with the NZBC Acceptable Solution E1/AS1 'Surface Water'. Foundation design must comply with the requirements of NZS 3604 'Timber-framed Buildings' or be as per specific engineering design.

The grade of adjacent finished ground must slope away from the building to avoid any possibility of water accumulation in accordance with the NZBC requirements.

2.4 SURFACE CLEARANCES

The clearance between the bottom edge of the cladding and paved/unpaved ground must comply with section 9.1.3 of E2/AS1. The finished floor level must also comply with these requirements. These clearances must be maintained throughout the life of the building.

Linea Oblique Weatherboard must overhang the bottom plate by a minimum of 50mm, as required by E2/AS1.

Linea Oblique Weatherboard must maintain a minimum clearance of 100mm from paved ground, and 175mm from unpaved ground.

On roofs and decks, the minimum clearance must be 50mm.

Do not install external cladding such that it may remain in contact with water or ground, refer to Figure 3.

2.5 MOISTURE MANAGEMENT

It is the responsibility of the specifier to identify moisture related risks associated with any particular building design.

Wall construction design must effectively manage moisture, considering both interior and exterior environments of the building, particularly in buildings that have a higher risk of wind driven rain penetration. The building should also be ventilated sufficiently to control moisture accumulation due to condensation, especially in artificially cooled/heated buildings.

Walls must include those provisions as required by the NZBC Acceptable Solution Clause E2/AS1. In addition, all wall openings, penetrations, junctions, connections, window sills, heads and jambs must incorporate appropriate flashings for waterproofing. The other materials, components and installation methods used to manage moisture in external walls, must comply with the requirements of relevant standards and the NZBC. For further guidance on designing for weathertightness, refer to BRANZ Ltd. and the Ministry of Business Innovation and Employment (MBIE) updates on the following websites respectively, www.branz.co.nz and www.building.govt.nz.

In addition, the following issues must also be considered:

- Sealant must be installed where detailed in this literature
- Where the walls are higher than two storeys, it is necessary to provide a horizontal flashing at the second floor level to drain the cavity
- The installation of smoke chimneys, pipe penetrations and other fixtures etc. must not track moisture into the wall or restrict the drainage of moisture to the exterior

2.6 STRUCTURE

2.6.1 Timber Framing

Timber-framed buildings must either be in accordance with NZS 3604 (Timber-framed Buildings) or designed as per specific engineering design. For a building requiring a specific engineering design, the framing stiffness must be equivalent to, or more than, the stiffness requirements of NZS 3604.

For specific design projects, the timber framing must be designed in accordance with the requirements of NZS 3603 and AS/NZS 1170.

For timber frame walls longer than 12m, it is best practice to allow for construction joints to accommodate movements generated due to timber shrinkage or deflections generated by loadings etc.

2.6.2 Wind Pressures

Linea Oblique Weatherboard is suitable for use in wind zones up to and including EH as defined in NZS 3604.

Linea Oblique Weatherboard is also suitable for use in specific design projects up to wind pressures of 2.5kPa (ULS).

2.7 FIRE RATED WALLS

Linea Oblique Weatherboard when fixed over timber cavity battens to external walls can achieve fire ratings up to 60/60/60 to comply with Clause C/AS1 of the NZBC, when the walls are constructed in accordance with the current James Hardie 'Fire and Acoustic' Design Manual.

Linea Oblique Weatherboard is classified as a 'non-combustible' material suitable for use on walls close to a boundary.

2.8 STRUCTURAL BRACING

Linea Oblique Weatherboard installed as per this specification cannot be used to achieve structural bracing. However, bracing can be achieved by using a James Hardie rigid air barrier board installed direct to framing instead of a flexible underlay or by using the Villaboard™ Lining bracing system on the internal face of the wall. Refer to the James Hardie Bracing Design Manual for further information.

2.9 ENERGY EFFICIENCY

External walls constructed as per this technical specification using Linea Oblique Weatherboard and bulk insulation, where the area of glazing is 30% or less of the total wall area, complies with the insulation requirements for walls in the NZBC Acceptable Solution H1/AS1 (Energy Efficiency Clause H1), Table 1.

To meet thermal insulation requirements for the construction, the bulk insulation as specified in Table 1 must be used. This insulation may be substituted with insulations having higher R-values. The thermal insulation of a wall changes when the size or spacing of timber framing is increased or decreased. The calculation used in Table 1 is based on a timber framing size 90 x 45mm and using an internal lining material such as Villaboard Lining or a 10mm plasterboard.

Table 1

Insulation capability		
Climate zone	R-value requirement	Minimum cavity insulation infill requirement
1 and 2	1.9 m ² °C/W	R2.0*
3	2.0 m ² °C/W	R2.2*

Total construction R-value depends on the insulation material used and the framing ratio. The insulation material R-values specified in this table are for studs spaced at 600mm centres and nogs spaced at 600mm centres.

* To achieve higher R-values of construction the wall insulation material must be replaced with an insulation material having higher R-values to suit the requirements.

For further guidance on insulation requirements refer to the current edition of 'House Insulation Guide' published by BRANZ.

3 Framing

3.1 GENERAL

Linea Oblique Weatherboard can be fixed either to a timber-frame or steel-frame.

For fixing to a steel frame Ask James Hardie on 0800 808 868 for specific requirements.

For Linea Oblique Weatherboard Vertical Installation:

- Studs must be provided at 600mm centres maximum
- Nogs must be provided at 600mm centres maximum

Note: For fixing Linea Oblique Weatherboard, fastener spacing is provided in Section 5.

3.2 TIMBER FRAMING

3.2.1 Dimensions

A 90 x 45mm minimum framing size is required.

3.2.2 Structural Grade

Timber grade used must be in accordance with timber grades specified in NZS 3604.

3.2.3 Durability

The external framing timber must be treated to a minimum H1.2 treatment. Higher treatment levels may be used, but check for the compatibility of treatment chemicals with other materials. Refer to the NZBC Acceptable Solution B2/AS1 Durability for further information about the durability requirements.

For timber treatment and allowable moisture content information refer to NZS 3602 (Timber and Wood-Based Products for use in Buildings) and NZS 3640 (Chemical Preservation of Round Sawed Timber) for minimum timber treatment selection and treatment requirements.

Also refer to the framing manufacturer's literature for further guidance on timber selection. Framing must be protected from moisture at the site in accordance with the framing manufacturer's recommendations.

3.2.4 Frame Construction

Use of timber framing must be in accordance with NZS 3604 and the framing manufacturer's specifications. The framing must be rigid and must not rely on the cladding for stability. Timber framing sizes and its set-out must comply with NZS 3604 and as specified in this technical specification.

The following framing is required:

- Studs must be provided at 600mm centres maximum
- Nogs must be provided at 600mm centres maximum
- An extra stud is required in internal corners
- For specific design projects exposed to wind speeds higher than 55m/sec the stud size and spacing must be as per the design requirements but not exceeding 600mm maximum

In case of gable end trusses sitting on top plates of the external wall frame, the frame size must be in accordance with truss design and specification supplied by the frame and truss manufacturer/supplier supported by an independent design producer statement.

3.3 SPECIAL FRAMING REQUIREMENTS

The following are special framing requirements for both timber and steel framing:

- Double studs are required at internal corners, refer to Figure 10
- Extra packers may be required at external corners

3.4 TOLERANCES

In order to achieve the required performance and an acceptable wall finish, it is imperative that framing is straight and true. Framing tolerances must comply with Table 2.1 of NZS 3604 and the manufacturer's specifications. All framing shall be made flush.

4 Preparation

4.1 FLEXIBLE UNDERLAY/HOMERAB PRE-CLADDING

Flexible underlay/HomeRAB™ Pre-Cladding must be provided as per the requirements of External Moisture Clause E2 of the NZBC. The flexible underlay selected for use must comply with Table 23 of E2/AS1.

The flexible underlay must be fixed in accordance with section 9.1.7 of E2/AS1 and the underlay manufacturer's recommendations.

Walls which are not lined on the inside face (e.g. garage walls or gable ends), must include a rigid sheathing or an air barrier behind the cladding which complies with Table 23 of E2/AS1. For attached garages, flexible underlays must be selected in accordance with the NZBC Acceptable Solution E2/AS1, Paragraph 9.1.3.4. James Hardie HomeRAB Pre-Cladding complies with these requirements and is suitable for use in this situation. It must be installed in accordance with the James Hardie Rigid Air Barriers installation manual.

4.2 RAB BOARD

For EH wind zone or for specific engineering design (SED) projects where the wind pressure is higher than 1.5kPa, James Hardie RAB™ Board must be used.

To achieve temporary weathertightness using James Hardie RAB Board, windows/doors need to be temporarily installed. Refer to the James Hardie Rigid Air Barriers installation manual for further information regarding its installation.

4.3 CAVITY CLOSURE/VENT STRIP

The James Hardie uPVC cavity vent strip must be installed at the bottom of all walls and above all openings constructed using the drained and ventilated cavity construction method. It is important that the openings in the cavity closure/vent strip are kept clear and unobstructed to allow free drainage and ventilation of cavities. James Hardie cavity closure/vent strip has an opening area of 1000mm²/m length.

4.4 CAVITY BATTENS

Linea Oblique Weatherboard must be installed on a cavity. The battens provide ventilation and drainage between the frame and the weatherboard and are considered a “packer” only in this specification.

The James Hardie horizontal cavity battens are H3.1 treated in accordance with NZS 3640 (Chemical preservation of rough and sawn timber) to comply with the durability requirements of B2/AS1.

James Hardie horizontal cavity battens meet the requirements of E2/AS1 and:

- Are minimum 20mm thick and 45mm wide
- Fixed horizontally to nogs
- Fixed vertically to studs at corners and openings
- Must be fixed by the cladding fixings to the main framing over the flexible underlay. Therefore until claddings are fixed the battens only need to be tacked to framing by 40 x 2.8mm or longer nails at 800mm centres
- Permit air circulation and water drainage

4.5 INTERMEDIATE SUPPORT

Where studs are at 600mm centres an intermediate means of restraining the flexible underlay and insulation from bulging into the cavity shall be installed. An acceptable method to achieve this is using one of the following options:

- 75mm galvanised mesh; or
- Polypropylene tape at 300mm centres fixed horizontally and drawn taut

No intermediate supports are required:

- When studs are spaced at 400mm centres; or
- When rigid air barriers are used

4.6 FLASHINGS

All wall openings, penetrations, intersections, connections, window sills, heads and jambs must be flashed prior to Linea Oblique Weatherboard installation. Refer to moisture management requirements in Clause 2.5. The flexible underlay/rigid air barrier must be appropriately incorporated with penetration and junction flashings using flashing tapes. Materials must be lapped in such a way that water tracks down to the exterior on the face of the flexible underlay or rigid air barrier board.

The selected flashing materials must comply with the durability requirements of the NZBC. For information refer to Table 20 of E2/AS1.

When using James Hardie rigid air barrier boards the entire framing around openings must be protected with a flashing tape. The tape must be finished over the face of the rigid air barrier. Ensure to check the compatibility of flashing tapes and sealants with their manufacturers. Refer to the James Hardie Rigid Air Barriers installation manual for further information.

4.7 JUNCTIONS AND PENETRATIONS

Refer to Clause 2.5 of this specification for moisture management requirements. All windows and doors must be detailed as per the requirements of this specification. For an example of window details for Linea Oblique Weatherboard which meet the performance requirements of E2 External Moisture, an approved document of the NZBC, refer to Figures 11 to 13.

5 Installation

5.1 GENERAL

Linea Oblique Weatherboard must be installed vertically using the cavity construction method as per the details and information published in this manual.

The two widths of Linea Oblique Weatherboard can be mixed to create the desired look.

Linea Oblique Weatherboard must be kept under cover whilst in storage or at sites and they must be dry at the time of their installation. All site-cut board edges must be sealed with Dulux Acraprime 501/1, Dulux 1 Step, Resene Quick Dry or a similar sealer compatible with the finish coat before installation.

Linea Oblique Weatherboard must be fully supported and fixed through James Hardie horizontal cavity battens. Ensure that cladding is hard against the battens to avoid drumminess.

This technical specification only covers the vertical installation of Linea Oblique Weatherboard. Refer to the Linea Oblique Weatherboard horizontal installation technical specification for horizontal installation.

5.2 FASTENER DURABILITY

Fasteners must meet the minimum durability requirements of the NZBC. NZS 3604 specifies the requirements for fixing materials to be used in relation to exposure conditions and are summarised in Table 2.

Fasteners must be fully compatible with the other materials that they are to be in contact with, to ensure the durability of the complete assembly.

Table 2

Exposure conditions and nail selection prescribed by NZS 3604		
NAIL MATERIAL		
Zone D	Zone C* outside sea spray zone, Zone B and geothermal hot spots	Bracing - all zones
Grade 316 Stainless	Hot-dipped galvanised or Grade 316 Stainless	Grade 316 Stainless

*Zone C areas where local knowledge dictates that increased durability is required, appropriate selection shall be made. Microclimate conditions as detailed in NZS 3604, Paragraph 4.2.4 require SED.

Also refer to the NZBC Acceptable Solution E2/AS1 Table 20 and 21 for information regarding the selection of suitable fixing materials and their compatibility with other materials.

5.3 FASTENER – SIZE AND LAYOUT

Linea Oblique Weatherboard must be fixed vertically to framing using fixings as specified in Table 3 below and follow the edge distance required for nails as shown in the details.

Table 3

Weatherboard fixing up to and including VH wind zone		
CAVITY CONSTRUCTION OVER FLEXIBLE UNDERLAY		
Linea Oblique Weatherboard 200	65x2.87mm D head nail or 65x2.87mm RounDrive ring shank nail or 60x3.15mm HardieFlex nail	Fix one nail 100mm from bottom edge of board per nog/plate, refer to Figure 6
Linea Oblique Weatherboard 300	65x2.87mm D head nail or 65x2.87mm RounDrive ring shank nails or 60x3.15mm HardieFlex nail	Fix one nail 150mm from bottom edge of board per nog/plate, refer to Figure 7

Weatherboard fixing up to and including VH wind zone

CAVITY CONSTRUCTION OVER HOMERAB PRE-CLADDING/RAB BOARD		
Linea Oblique Weatherboard 200	75x3.06mm D head nail or 75x3.15mm RounDrive ring shank nail or 75x3.15mm HardieFlex nail	Fix one nail 100mm from bottom edge of board per nog/plate, refer to Figure 6
Linea Oblique Weatherboard 300	75x3.06mm D head nail or 75x3.15mm RounDrive ring shank nail or 75x3.15mm HardieFlex nail	Fix one nail 150mm from bottom edge of board per nog/plate, refer to Figure 7

Weatherboard fixing EH wind zone and SED projects

CAVITY CONSTRUCTION OVER RAB BOARD		
Linea Oblique Weatherboard 200	75x3.06mm D head nail or 75x3.15mm RounDrive ring shank nail or 75x3.15mm HardieFlex nail	Fix one nail 100mm from bottom edge of board per nog/plate Refer to Figure 8
Linea Oblique Weatherboard 300	75x3.06mm D head nail or 75x3.15mm RounDrive ring shank nail or 75x3.15mm HardieFlex nail	Fix one nail at 150mm from bottom edge of board per nog/plate. Refer to Figure 9

For other fixing options Ask James Hardie on 0800 808 868.

- When fixing the weatherboards using nail guns, refer to the nail gun manufacturer for information about nails and the type of nail gun to be used
- D head nails - finish nails 2mm below weatherboard surface
- RounDrive nails - finish nails flush with weatherboard surface
- HardieFlex nails - finish nails flush with weatherboard surface

6 Joints

6.1 VERTICAL JOINT

Linea Oblique Weatherboard vertical joint shall be formed using the ship lap edge of the Linea Oblique Weatherboard. Ensure that the Linea Oblique Weatherboards are securely interlocked before nailing, refer to Figures 6 to 9.

6.2 HORIZONTAL JOINT

Linea Oblique Weatherboard can run continuously over floor joists without a flashed horizontal joint when LVL timber floor joists or engineered joist are used, refer to Figure 17.

When using a solid timber joist, a horizontal joint or a movement joint must be formed at floor joist, refer to Figure 19.

6.3 DRAINAGE JOINT

After every two floors a horizontal drainage joint flashing is required as per E2/AS1, refer to Figure 22.

6.4 EXTERNAL CORNER

An external box corner flashing is used to fix the external corners, refer to Figure 11. Alternatively an Axent™ Trim external boxed corner can also be formed, refer to Figure 12.

6.5 INTERNAL CORNER

An internal corner flashing is to be used to form an internal corner joint, refer to Figure 10.

An extra stud is required in internal corners.

Note: All joint mouldings to be fixed at 400mm centres both sides.

7 Finishes

7.1 PREPARATION

The D head nail must be finished 2mm below the weatherboard surface. The nail holes must be filled with an exterior grade two part builders fill, ie. CRC ADOS Builders Fill or similar two part external grade filler. The RounDrive nail heads must finish flush with weatherboard surface.

7.2 PAINTING

Linea Oblique Weatherboard is pre-primed and is suitable for site applied acrylic paints.

In order to seal cut edges or sanded patches, Dulux 1 Step, Acraprime 501/1, Resene Quick Dry, Taubmans Underproof Acrylic Primer Undercoat or a similar product should be applied. The primer should be compatible with the paint to be used.

Painting of Linea Oblique Weatherboard is mandatory to meet the durability requirements of the NZBC and the 25 year James Hardie product warranty. Linea Oblique Weatherboard must be dry and free of any dust or grime before painting. The weatherboards must be painted within 90 days of their installation. There is no restriction on the LRV of paint to be applied on the Linea Oblique Weatherboard.

James Hardie recommends a minimum of two coats of exterior grade acrylic paint. Follow the paint manufacturer's recommendations to prepare the surface and to adequately cover and conceal the weatherboard fixings.

7.3 FLEXIBLE SEALANT

Sealant used must comply with the relevant requirements of the NZBC. Their application and usage must be in accordance with the manufacturer's instructions. Check with the sealant manufacturer prior to coating over sealant. Some sealant manufacturers do not recommend coating over their product.

8 Storage and handling

When storing Linea Oblique Weatherboard, they must be laid flat on a smooth level surface. Edges and corners must be protected from chipping.

To ensure optimum performance, store weatherboards under cover and keep dry prior to fixing. If the weatherboards become wet, allow them to dry thoroughly before fixing.

Do not carry weatherboards on the flat, carry on edge to avoid excessive bending.

9 Maintenance

It is the responsibility of the specifier to determine normal maintenance requirements to maintain the effectiveness of the cladding. The extent and nature of maintenance required will depend on the geographical location and exposure of the building.

As a guide, it is recommended that the basic normal maintenance tasks shall include, but not be limited to:

- Washing down exterior surfaces every 6-12 months*
- Re-coating exterior protective finishes**
- Regular inspection and repair if necessary of the cladding joints, sealants, nail head fillers
- Cleaning out gutters, down pipes and overflow pipes as required
- Pruning back vegetation which is close to or touching the building as well as ensuring the NZBC ground clearance requirements are maintained, especially where gardens are concerned
- The clearance between the bottom edge of the Linea Oblique Weatherboard and the finished/unfinished ground must always be maintained

**Do not use a water blaster to wash down the cladding. In extreme coastal conditions or sea spray zones, wash every 3-4 months.*

***Refer to your paint manufacturer for washing down and recoating requirements related to paint performance.*

10 Product information

10.1 MANUFACTURING AND CLASSIFICATION

Linea Oblique Weatherboard is an advanced lightweight cement composite cladding, manufactured using James Hardie formulation. Basic composition is Portland cement, ground sand, cellulose fibre and water. The product is easily identified by the name 'Linea Oblique'.

Linea Oblique Weatherboard is manufactured to Australian/New Zealand Standard AS/NZS 2908.2 'Cellulose-Cement Products' (ISO 8336 'Fibre-Cement Flat Sheet').

Linea Oblique Weatherboard is classified Type A, Category 2 in accordance with AS/NZS 2908.2 "Cellulose-Cement Products".

For Safety Data Sheets (SDS) visit www.jameshardie.co.nz or Ask James Hardie on 0800 808 868.

10.2 PRODUCT MASS

Linea Oblique Weatherboard is manufactured in 16mm thickness and has a mass of 20.57kg/m² for 200mm and 19.67kg/m² for 300mm.

Linea Oblique Weatherboard is defined as a Light Weight Wall Cladding (not exceeding 30kg/m²) as per NZS 3604.

10.3 DURABILITY

Linea Oblique Weatherboard and James Hardie rigid air barrier installed and maintained as per this technical specification will meet the durability requirement for cladding as per the NZBC clause B2 Durability.

10.3.1 Resistance to Moisture/Rotting

Linea Oblique Weatherboard is resistant to permanent moisture induced deterioration (rotting) and meets the requirements of the following tests in accordance with the AS/NZS 2908.2:

- Heat Rain (Clause 6.5)
- Water Permeability (Clause 8.2.2)
- Warm Water (Clause 8.2.4)
- Soak Dry (Clause 8.2.5)

10.3.2 Control of External Fire Spread

Linea Oblique Weatherboard meets the requirements of Appendix C C7.1.1 and is classified as 'Non-Combustible Material' which is suitable for use as external wall cladding and complies with the requirements of Paragraph 5.4 of the NZBC Acceptable Solution C/AS1 and Paragraph 5.8.1 of Acceptable Solutions C/AS2 to C/AS6 of the NZBC.

10.3.3 Alpine Regions

In regions subject to freeze/thaw conditions, Linea Oblique Weatherboard and James Hardie rigid air barrier must not be in direct contact with snow or ice build up for extended periods, e.g. external walls in alpine regions must be protected where snowdrifts over winter are expected.

These products meet the requirements of the AS/NZS 2908.2 Clause 8.2.3.

11 Safe working practices

11.1 STAY HEALTHY WHEN WORKING WITH BUILDING PRODUCTS CONTAINING CRYSTALLINE SILICA

Crystalline Silica

What is it? Why and when is it a health hazard?

Crystalline Silica is

- Commonly known as sand or quartz
- Found in many building products e.g. concrete, bricks, grout, wallboard, ceramic tiles, and all fibre cement materials

Why is Crystalline Silica a health hazard?

- Silica can be breathed deep into the lungs when present in the air as a very fine (respirable) dust
- Exposure to silica dust without taking the appropriate safety measures to minimise the amount being breathed in, can lead to a potentially fatal lung disease – silicosis – and has also been linked with other diseases including cancer. Some studies suggest that smoking may increase these risks
- The most hazardous dust is the dust you cannot see!









When is Crystalline Silica a health hazard?

- It's dangerous to health if safety protocols to control dust are not followed when cutting, drilling or rebating a product containing crystalline silica
- Products containing silica are harmless if intact (e.g. an un-cut sheet of wall board)

FAILURE TO ADHERE TO OUR WARNINGS, SAFETY DATA SHEETS AND INSTALLATION INSTRUCTIONS WHEN WORKING WITH JAMES HARDIE PRODUCTS MAY LEAD TO SERIOUS PERSONAL INJURY OR DEATH.

11.2 AVOID BREATHING IN CRYSTALLINE SILICA DUST!

Safe working practices

-  NEVER use a power saw indoors or in a poorly ventilated area
-  NEVER dry sweep
-  ALWAYS use M Class extractor unit as a minimum and always hose down with water/wet wipe for clean up
-  NEVER use grinders
-  ALWAYS use a circular sawblade specifically designed to minimise dust creation when cutting fibre cement – preferably a sawblade that carries the HardieBlade™ logo or one with at least equivalent performance
-  ALWAYS follow tool manufacturers' safety recommendations
-  ALWAYS expose only the minimum required depth of blade for the thickness of fibre cement to be cut
-  ALWAYS wear an approved properly-fitted, approved dust mask (P1 or P2) or respirator

Use one of the following methods based on the required cutting rate:





BEST

- HardieKnife™
- Hand guillotine
- Fibreshear





BETTER

- Dust reducing circular saw equipped with HardieBlade™ Saw Blade and M Class extractor unit.

Working outdoors

-  Make sure you work in a well ventilated area
-  Position cutting station so wind will blow dust away from yourself and others in the working area
-  Cut products with either a HardieKnife™ or fibre cement shears or, when not feasible, use a HardieBlade™ Saw Blade (or equivalent) and a dust-reducing circular saw attached to a M Class extractor unit
-  When sawing, sanding, rebating, drilling or machining fibre cement products, always:
 - Wear your P1 or P2 mask (correctly fitted in accordance with manufacturers' instructions) and when others are close by, ask them to do the same
 - If you are not clean shaven, then use a powered air respirator with a loose fitting head top
 - Wear safety glasses
 - Wear hearing protection
 - When others are close by, ask them to do the same

Working indoors

-  Never cut using a circular saw indoors
-  Position cutting station in a well ventilated area
-  Cut ONLY using a HardieKnife™, hand guillotine or fibreshears (manual, electric or pneumatic)
-  Make sure you clean up BUT never dry sweep. Always hose down with water/wet wipe or use an M Class extractor unit

IF CONCERN STILL EXISTS ABOUT EXPOSURE LEVELS OR YOU DO NOT COMPLY WITH THE ABOVE PRACTICES, YOU SHOULD ALWAYS CONSULT A QUALIFIED INDUSTRIAL HYGIENIST.

Working Instructions

- Refer to Recommended Safe Working Practices before starting any cutting or machining of product

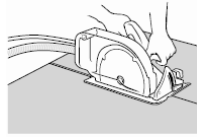

HardieBlade™ Saw Blade

The HardieBlade™ Saw Blade used with a dust-reducing saw is ideal for fast, clean cutting of James Hardie fibre cement products. A dust-reducing saw uses a dust deflector or a dust collector connected to a vacuum system. When sawing, clamp a straight-edge to the sheet as a guide and run the saw base plate along the straight edge when making the cut

Hole-Forming

For smooth clean cut circular holes:

- Mark the centre of the hole on the sheet
- Pre-drill a 'pilot' hole
- Using the pilot hole as a guide, cut the hole to the appropriate diameter with a hole saw fitted to a heavy duty electric drill

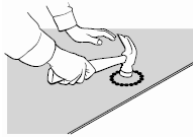

For irregular holes:

- Small rectangular or circular holes can be cut by drilling a series of small holes around the perimeter of the hole then tapping out the waste piece from the sheet face
- Tap carefully to avoid damage to sheets, ensuring that the sheet edges are properly supported

11.3 STORAGE AND DELIVERY

Keeping products and people safe

Off loading

- 👍 James Hardie products should be off-loaded carefully by hand or by forklift
- 👍 James Hardie products should not be rolled or dumped off a truck during the delivery to the jobsite

Storage

James Hardie products should be stored:

- 👍 In their original packaging
- 👍 Under cover where possible or otherwise protected with a waterproof covering to keep products dry
- 👍 Off the ground – either on a pallet or adequately supported on timber or other spacers
- 👍 Flat so as to minimise bending

James Hardie products must not be stored:

- 👎 Directly on the ground
- 👎 In the open air exposed to the elements

JAMES HARDIE IS NOT RESPONSIBLE FOR DAMAGE DUE TO IMPROPER STORAGE AND HANDLING.

11.4 TIPS FOR SAFE AND EASY HANDLING

Weatherboard products

- 👍 Do not lift planked products flat and in the middle
- 👍 Carry the products on the edge
- 👍 If only one person is carrying the product, hold it in the middle and spread arms apart to better support the product
- 👍 If two people are carrying the plank, hold it near each end and on edge
- 👍 Exercise care when handling weatherboard products to avoid damaging the edges/corners











Sheet products

- 👍 Carry with two people
- 👍 Hold near each end and on edge
- 👍 Exercise care when handling sheet products to avoid damaging the edges/corners

12 Product and accessories



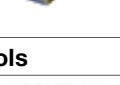



Linea Oblique Weatherboard information						
Product	Description	Size (mm)			Code	
		Thickness	Length	Width		
	Linea Oblique Weatherboard A 16mm profiled weatherboard for residential cladding. Factory sealed on all six sides. Each weatherboard has a manila white colour primer applied on its face, which accepts a wide range of paint finishes.	16	2700	200	404855	
					300	404856
			4200	200	404849	
				300	404848	

Note: All dimensions and masses provided are approximate only and are subject to manufacturing tolerances.

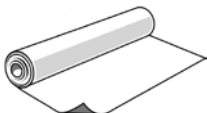
Accessories/tools supplied by James Hardie			
Accessories	Description	Size	Code
	James Hardie Horizontal Cavity Batten 20mm H3.1 Timber treated batten the cladding is fixed over	2700mm long	305862
	Oblique Trimline Joint Flashing Aluminium extrusion used behind cladding at horizontal joints.	3000mm long	305826
	JH Weatherboard Internal 'W' Corner Anodised aluminium extrusion used to create internal corners.	2700mm long	300386
	Linea Oblique Weatherboard External Box Corner Anodised aluminium extrusion used to create external corners.	2700mm long 4000mm long	305825 305873
	uPVC Vent Strip PVC moulding used as vermin proofing.	3000mm long	302490
	Trimline Horizontal Jointer A jointer to cover the butt joint of Oblique Trimline Joint Flashing	100mm long	305871
	Trimline External Corner Jointer Joins Trimline Joint Flashing at an external corner		305870
	Trimline Internal Corner Jointer Joins Trimline Joint Flashing at an internal corner		305872
	Linea Oblique Plug To fill recess in Linea Oblique Weatherboard		305930
Tools			
	HardieBlade™ Saw Blade Diamond tip fibre cement circular saw blade. Spacers not included.	184mm 254mm	300660 303375

Accessories/tools not supplied by James Hardie

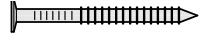
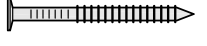
James Hardie recommends the following products for use in conjunction with Linea Oblique Weatherboard and James Hardie rigid air barrier. James Hardie does not supply these products and does not provide a warranty for their use. Please contact component manufacturer for information on their warranties and further information on their products.

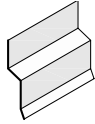
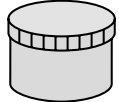
Product	Description
	Flexible underlay Must comply with Table 23 of E2/AS1.
	Flexible window opening flashing tape A flexible self-adhesive tape used in preparation of a window. Refer to the window installation section in this manual for more information. e.g. Protecto or SUPER-STICK Building Tape® by Marshall Innovations or 3M™ All Weather Flashing Tape 8067 by 3M™ Marshall Innovations: 0800 776 9727 3M™: 0800 474 787
	Rigid air barrier vertical joint sealing tape The tape to be used to seal James Hardie rigid air barrier vertical joints. SUPER-STICK Building Tape® by Marshall Innovations or 3M™ All Weather Flashing Tape 8067 by 3M™ Marshall Innovations: 0800 776 9727 3M™: 0800 474 787
	Flexible Sealant Bostik Seal N Flex-1, Sikaflex AT Facade, Sikaflex MS or similar.
	65 x 2.87mm 'D' head nail or 65 x 2.87 RoundDrive nail (ring shank hot dipped galvanised/stainless steel) For fixing Linea Oblique Weatherboard.
	75 x 3.06mm 'D' head nail or 75 x 3.15 RoundDrive nail (hot dipped galvanised or ring shank stainless steel) For fixing Linea Oblique Weatherboard.
	40 x 2.8mm or longer HardieFlex™ nail. For fixing timber cavity battens and aluminium flashings.
	Meter box Refer electrical suppliers.
	Head flashing Required over window heads to be supplied by window installer. Material must comply with Table 20 and 21 of E2/AS1.
	Exterior grade filler CRC ADOS Builders Fill or similar two part filler to fill over nail holes

13 Details

The following generic details have been provided in this document for cavity construction methods.

Table 5

Details		
Description	Cavity Construction	
	Figure No.	Page No.
Framing set out	Figure 1	15
Cladding and James Hardie horizontal batten setout	Figure 2	16
Ground clearance	Figure 3	17
Soffit detail	Figure 4	17
No soffit detail	Figure 5	18
Vertical joint 200mm weatherboard width up to VH wind zone	Figure 6	18
Vertical joint 300mm weatherboard width up to VH wind zone	Figure 7	19
Vertical joint 200mm weatherboard width EH wind zone and SED	Figure 8	19
Vertical joint 300mm weatherboard width EH wind zone and SED	Figure 9	20
Internal corner	Figure 10	20
External aluminium box corner	Figure 11	21
External box corner	Figure 12	21
Window sill	Figure 13	22
Window head	Figure 14	22
Window jamb	Figure 15	23
Window jamb flashing	Figure 16	23
Over joist at floor level	Figure 17	24
Butt jointing of Vertical Linea Oblique Weatherboard	Figure 18	25
Trimline flashing joint at floor level	Figure 19	25
Trimline flashing joint external corner	Figure 20	26
Trimline joint	Figure 21	27
Drained flashing joint at floor level	Figure 22	28
Drained flashing joint at floor joist	Figure 23	29
Apron flashing detail	Figure 24	30
Parapet flashing	Figure 25	30
Roof to wall junction detail	Figure 26	31
Meter box at sill	Figure 27	31
Meter box at jamb	Figure 28	32
Meter box at head	Figure 29	32
Enclosed deck	Figure 30	33
Pipe penetration	Figure 31	34
Cladding installed	Figure 32	35
Garage head	Figure 33	36
Garage jamb	Figure 34	36

Figure 1: Framing set out

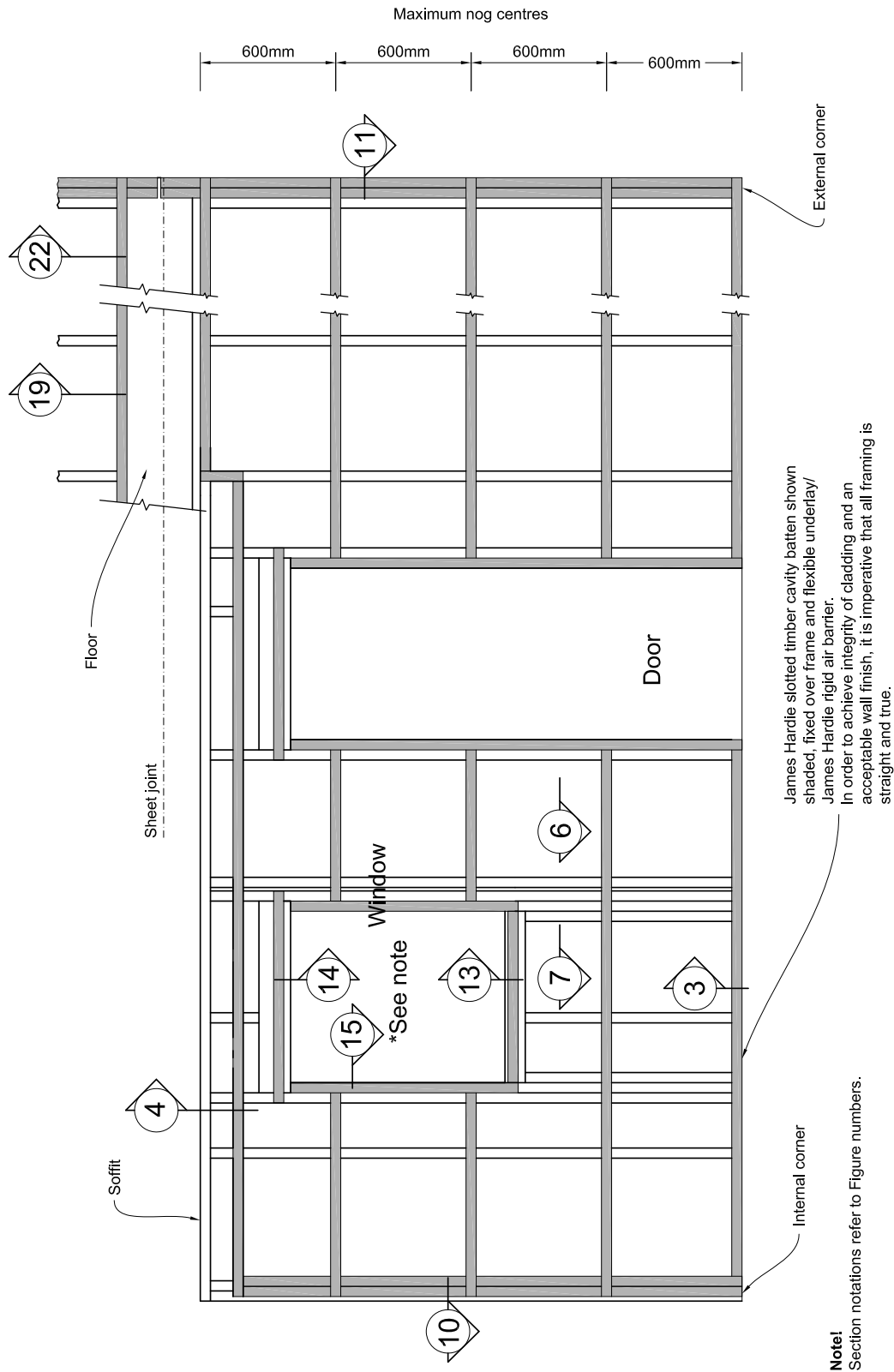

WALL ELEVATION

Figure 2: Cladding and James Hardie horizontal batten setout

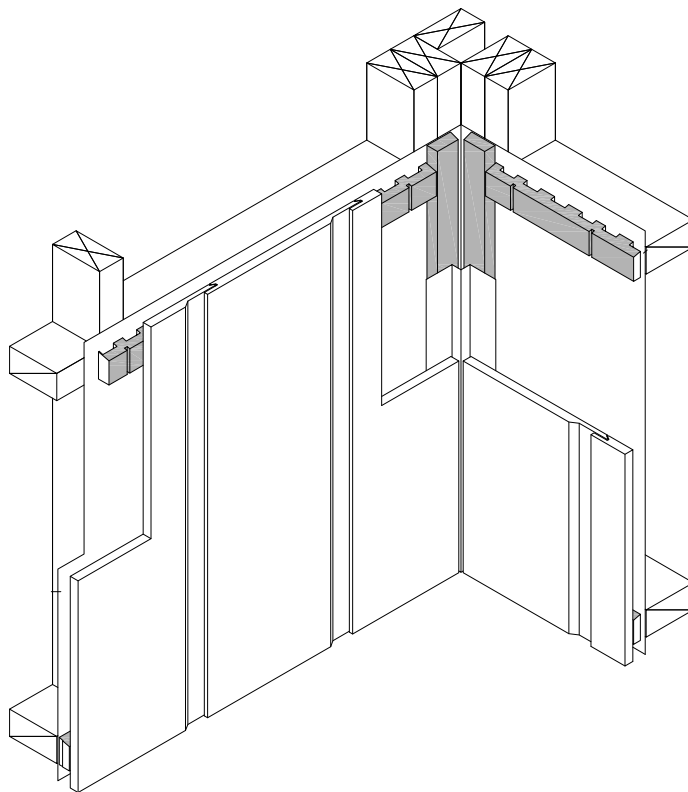
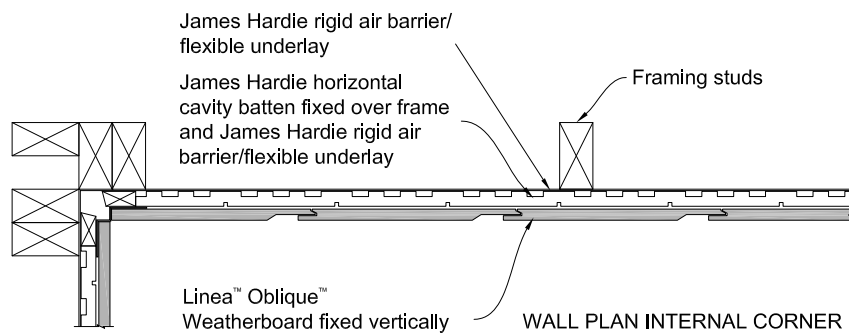
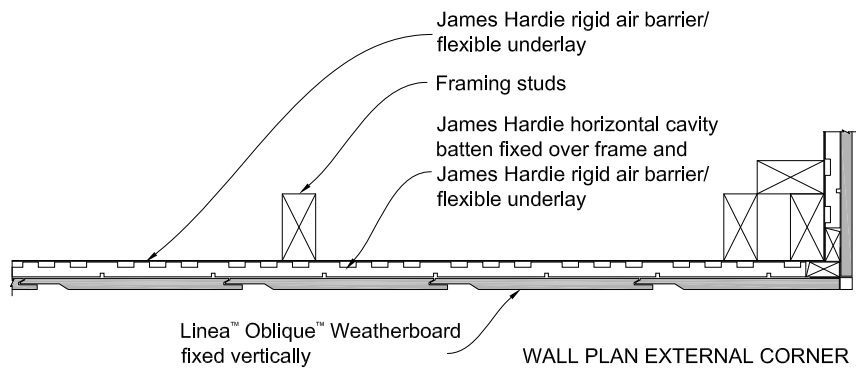

Figure 3: Ground clearance

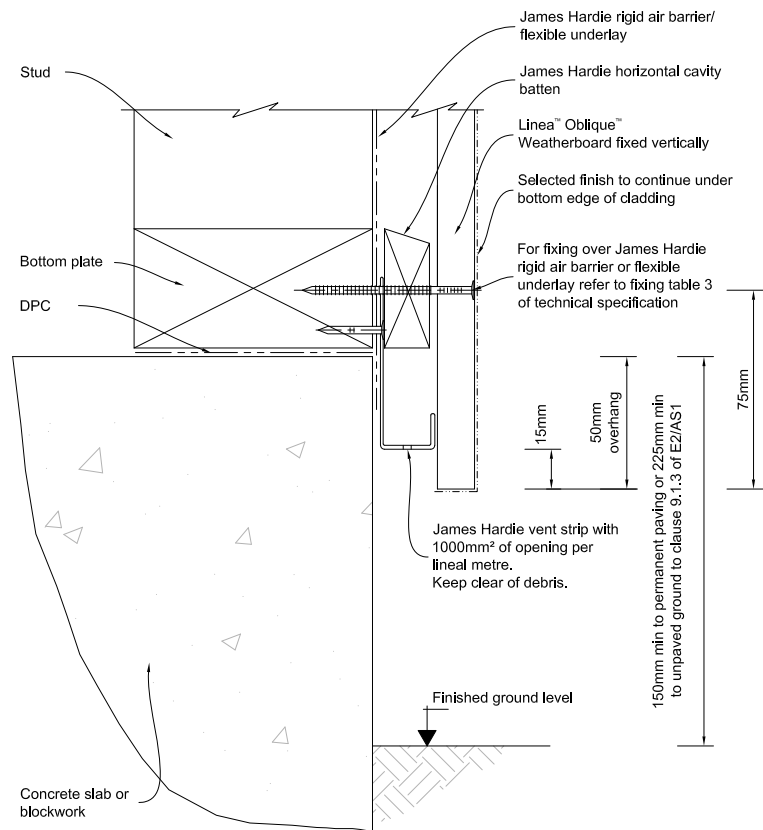

Figure 4: Soffit detail

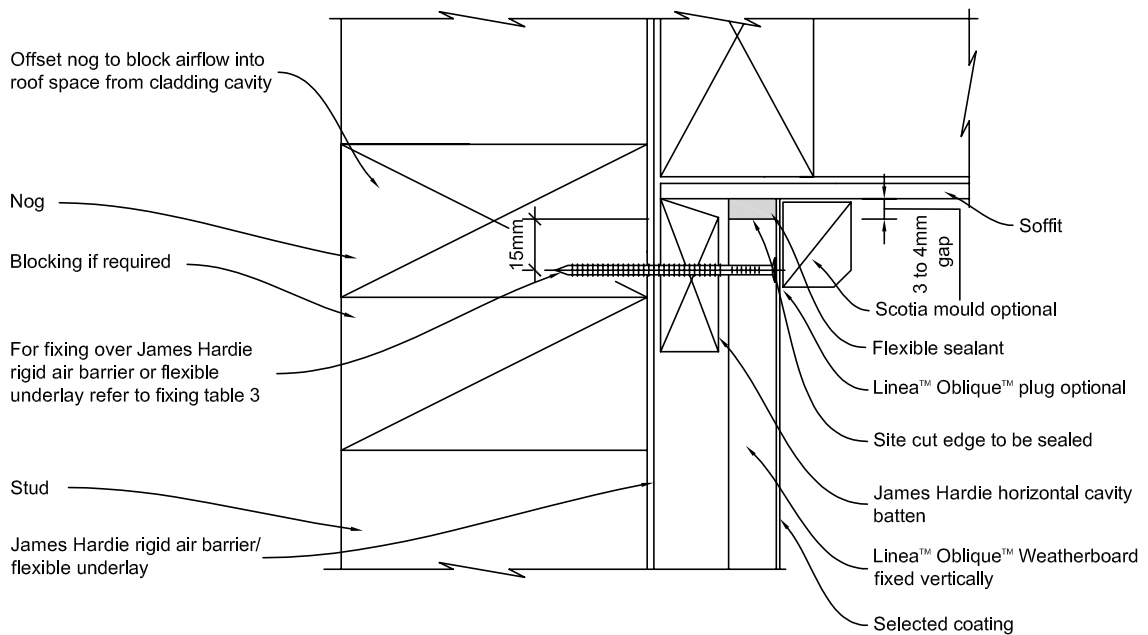

Figure 5: No soffit detail

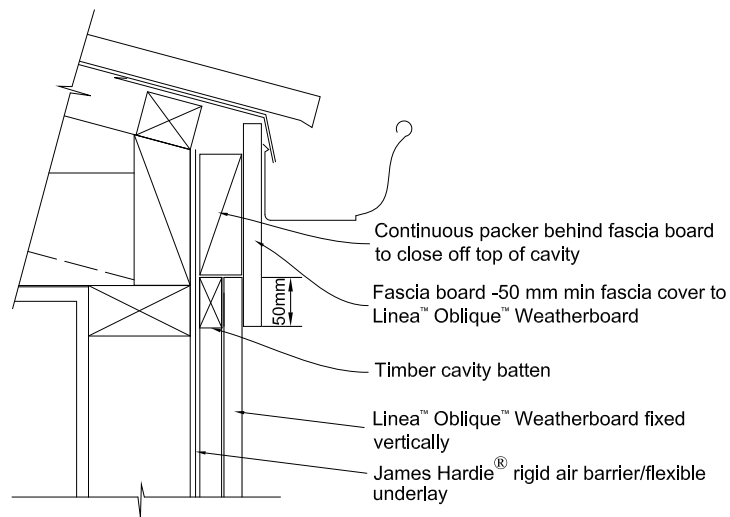

Figure 6: Vertical joint 200mm weatherboard width up to VH wind zone

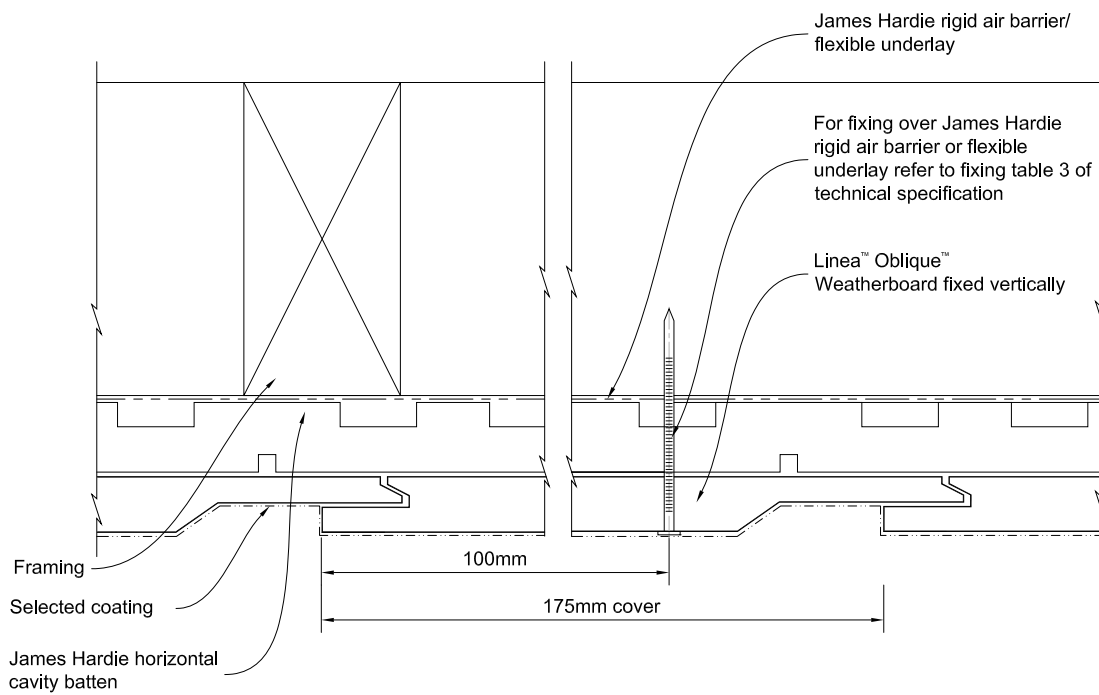

Figure 7: Vertical joint 300mm weatherboard width up to VH wind zone

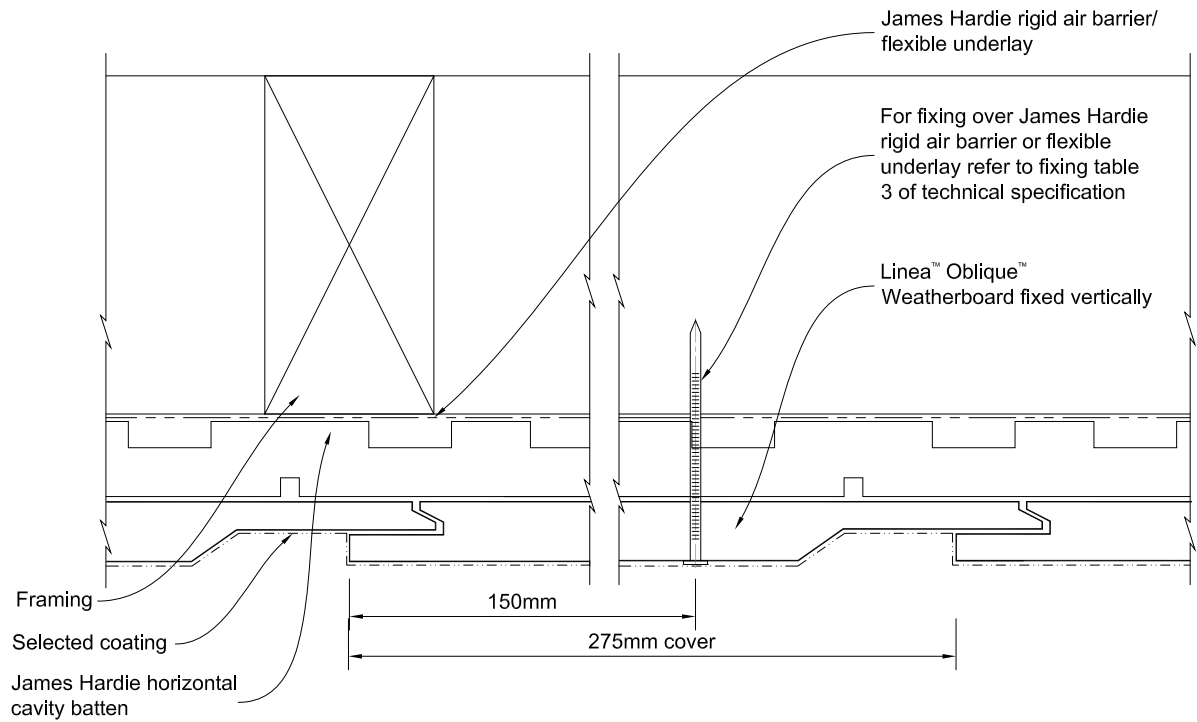

Figure 8: Vertical joint 200mm weatherboard width EH wind zone and SED

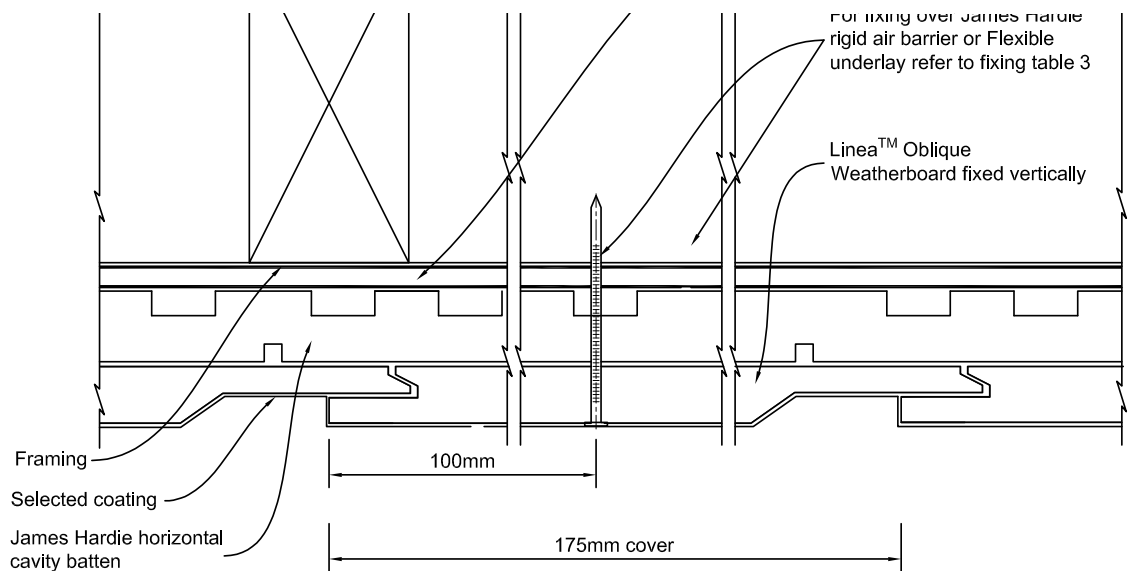

Figure 9: Vertical joint 300mm weatherboard width EH wind zone and SED

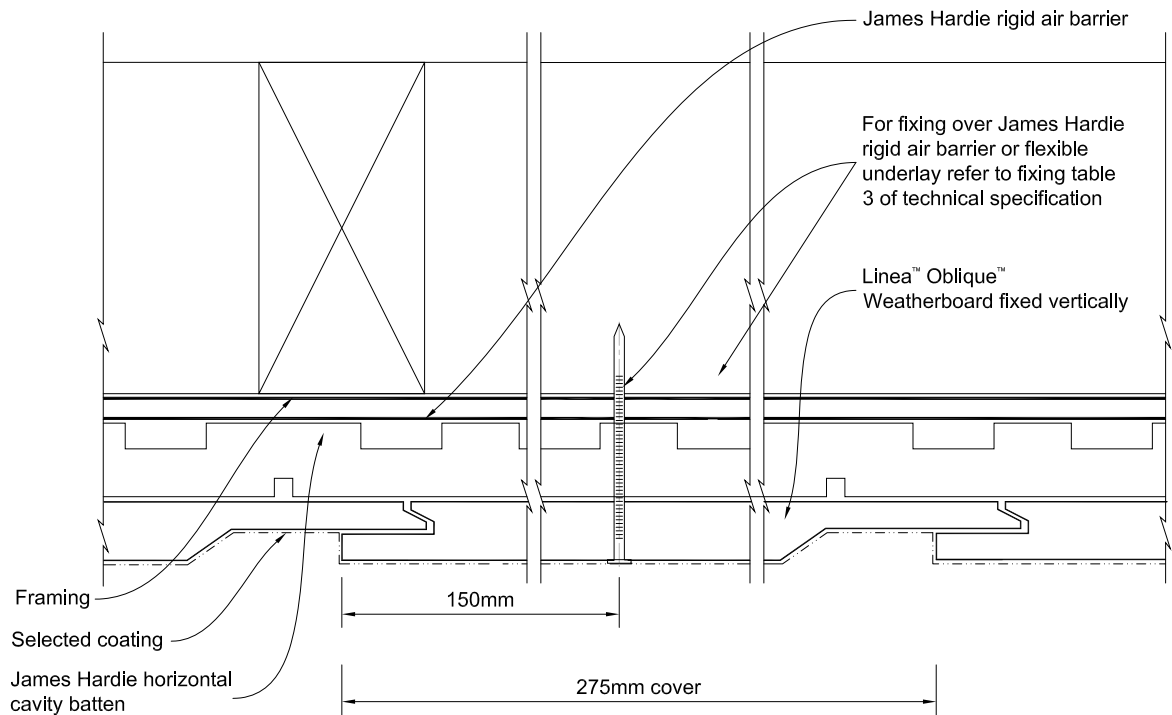
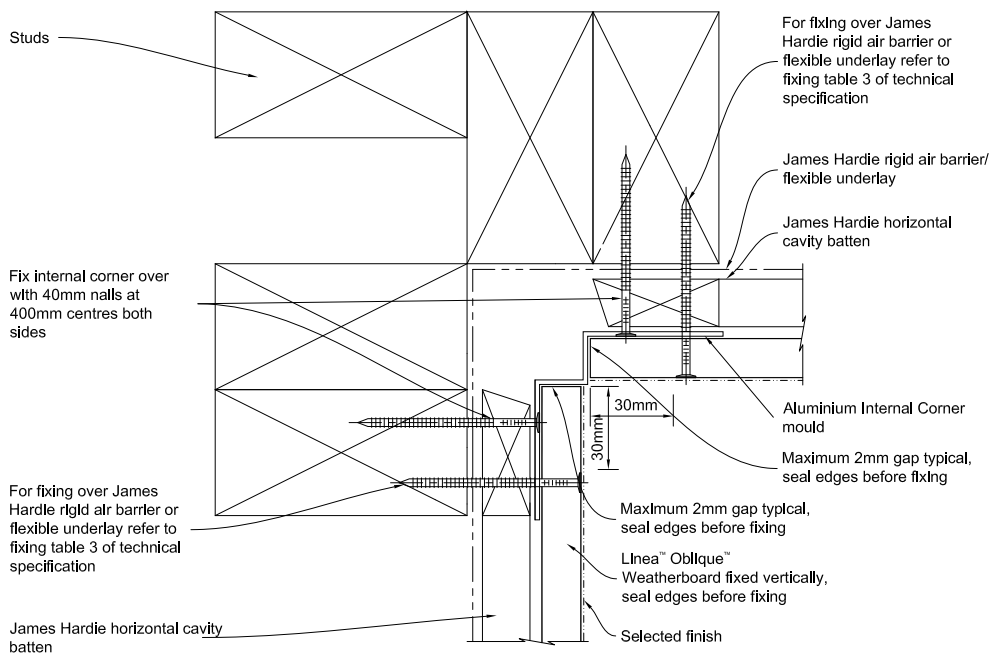

Figure 10: Internal corner



interactive assembly instructions available
<http://wksp.nz/jh-lio-vmc>



Get WORKINGSPEC from Apple App Store/Google Play

Figure 11: External aluminium box corner

interactive assembly instructions available

<http://wksp.nz/jh-llo-vexx>



Get WORKINGSPEC from Apple App Store/Google Play

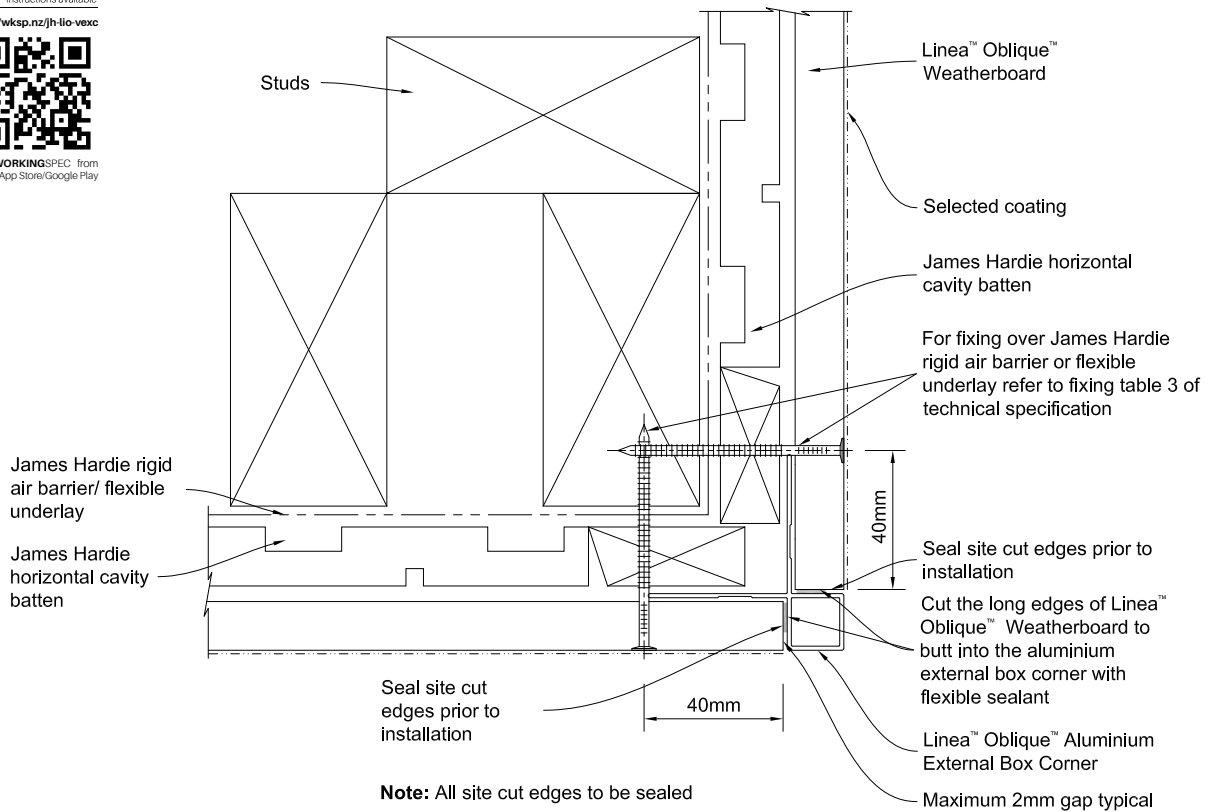

Figure 12: External box corner

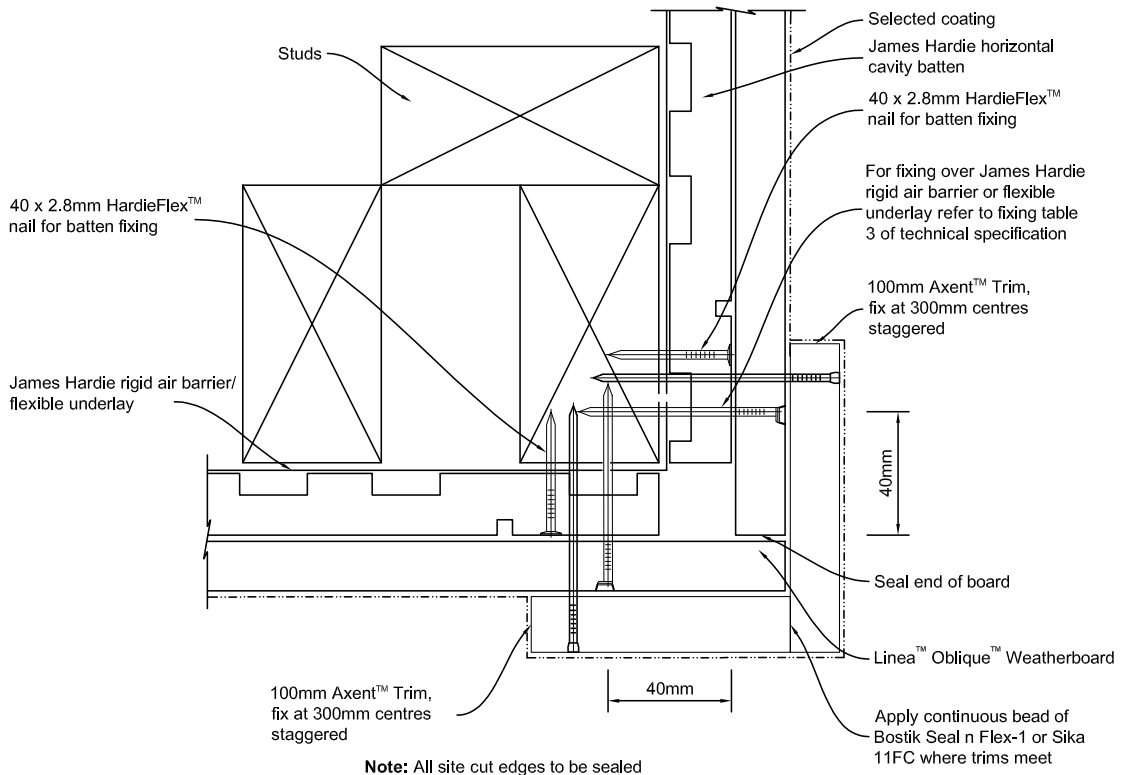
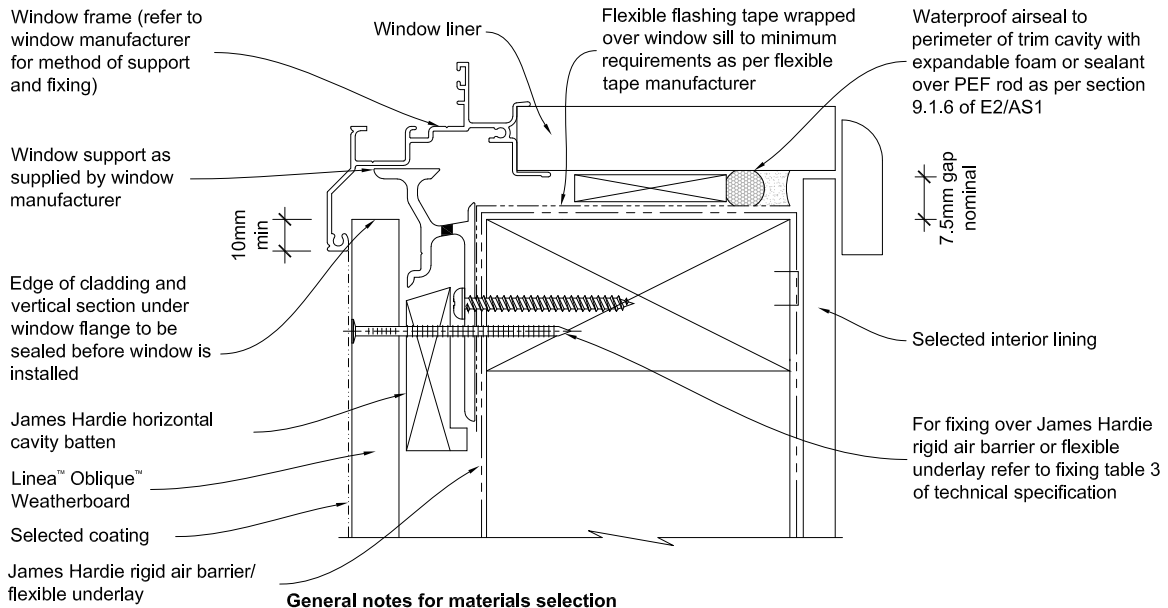

Figure 13: Window sill



General notes for materials selection

1. Flashing materials must be selected based on environmental exposure, refer to NZS 3604 and Table 20 of NZBC E2/AS1
2. Flexible underlay must comply with acceptable solution E2/AS1
3. Flashing tape must have proven compatibility with the selected flexible underlay and other materials with which it comes into contact
4. When James Hardie rigid air barriers are used flashing tape to be applied to the entire opening

Refer to the manufacturer or supplier for technical information for these materials.

Interactive assembly instructions available

<http://wksp.nz/jh-lo-vwin>



Get WORKINGSPEC from Apple App Store/Google Play

Figure 14: Window head

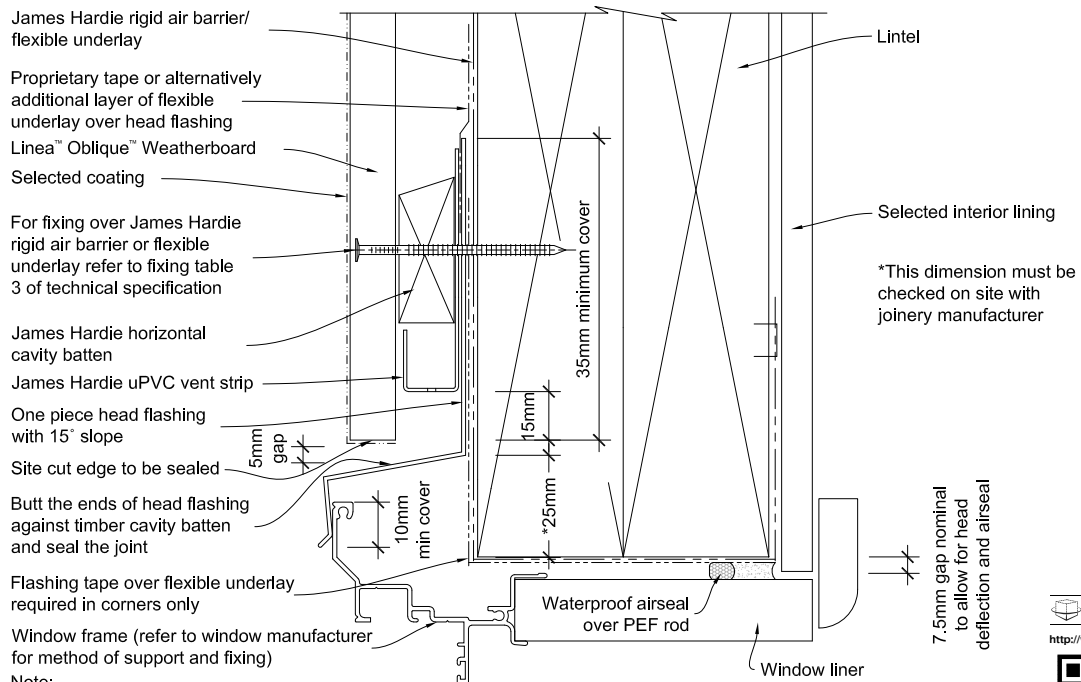

- Note:
- When James Hardie rigid air barriers are used flashing tape to be applied to the entire window opening
 - Sealant must be installed between head flashing and window flange in VH and EH wind zones and SED projects
 - Alternatively, the head flashings can be formed with stop ends as per E2/AS1

Interactive assembly instructions available

<http://wksp.nz/jh-lo-vwin>



Get WORKINGSPEC from Apple App Store/Google Play

Figure 15: Window jamb

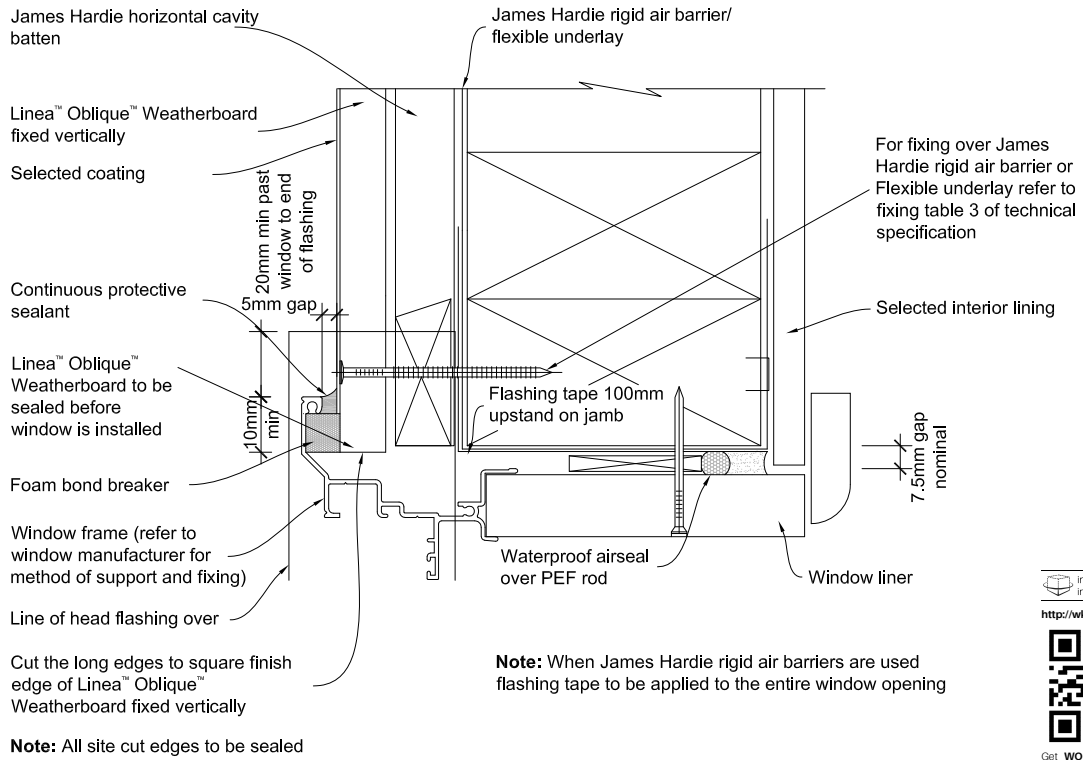

Figure 16: Window jamb flashing

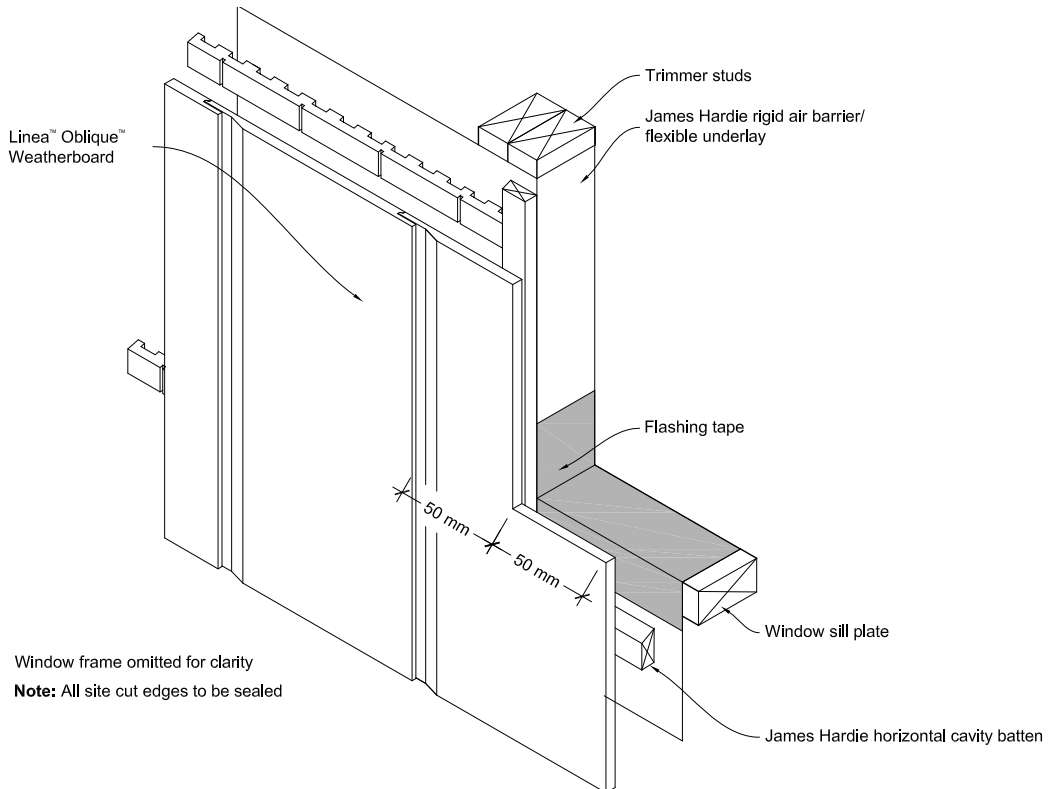

Figure 17: Over joist at floor level

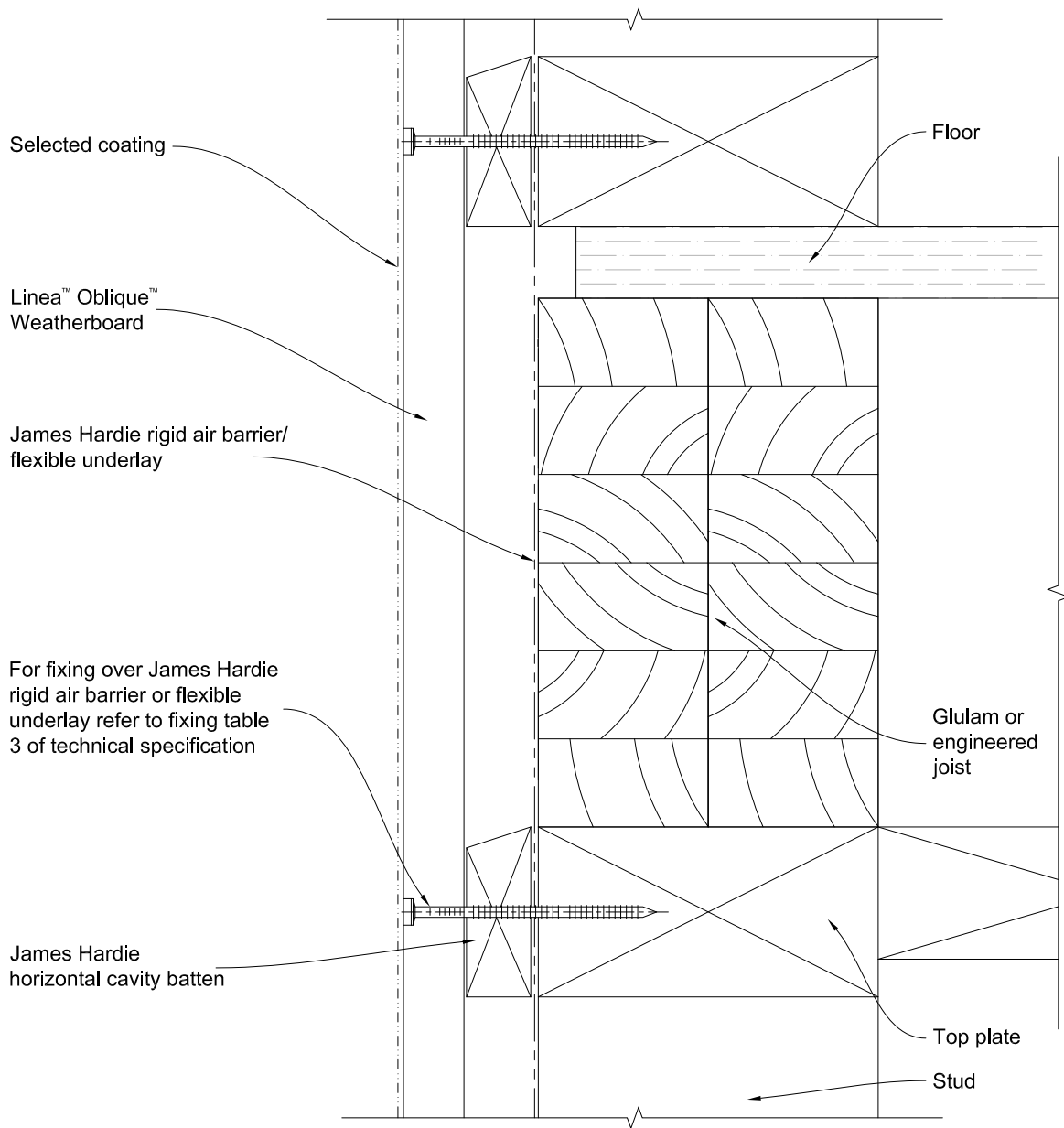

Figure 18: Butt jointing of Vertical Linea Oblique Weatherboard

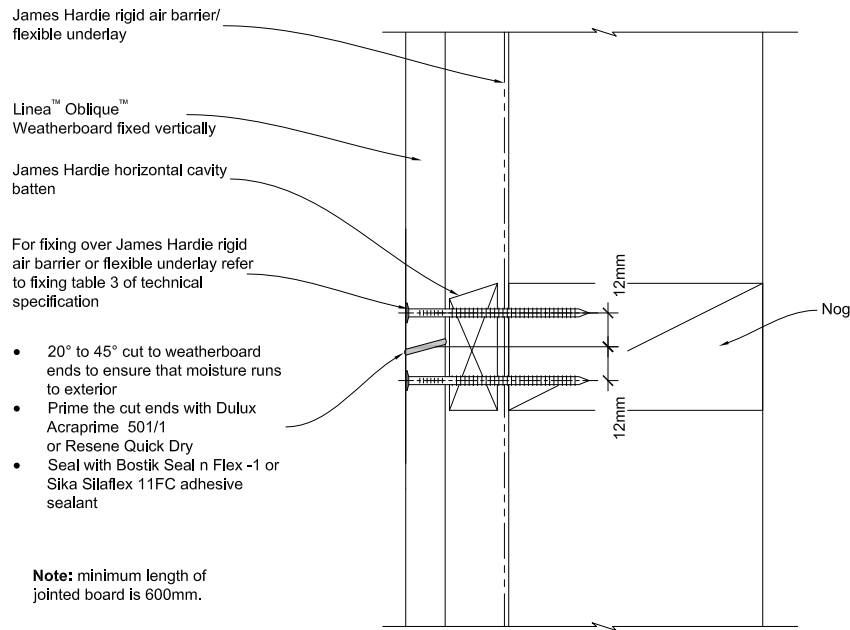
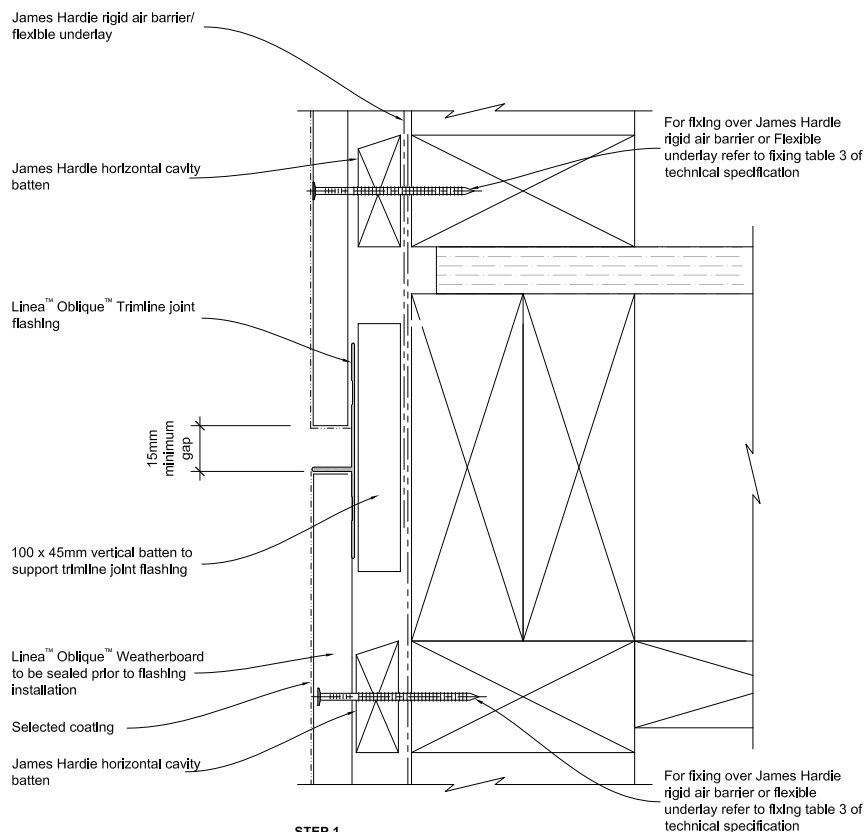

Figure 19: Trimline flashing joint at floor level



STEP 1

STEP 1

- Ensure flat James Hardie rigid air barrier / Flexible underlay is in place.

STEP 2

- James Hardie horizontal cavity batten to be installed over the studs and nogs. - Nylon strapping intermediate support to hold insulation in place between studs.

STEP 3

- Install the lower weatherboards with aluminium trimline flashing.
- Install the upper weatherboard keeping a 15mm gap.

Notes:

- The aluminium trimline flashing is installed prior to weatherboard. Apply two 6mm thick lines of adhesive sealant on the bottom portion of aluminium trimline flashing to seal. Take care to ensure continuous seal is formed between weatherboard and aluminium trimline flashing.
- The sealant must continue between flashing flange and weatherboard edge.
- Install purpose-made jointer 50mm over each end of trimline flashing and seal with flexible sealant to prevent water ingress.

interactive assembly
instructions available

<http://wksp.nz/jh-lio-vtrjfl>



Get WORKINGSPEC from
Apple App Store/Google Play

Figure 20: Trimline flashing joint external corner

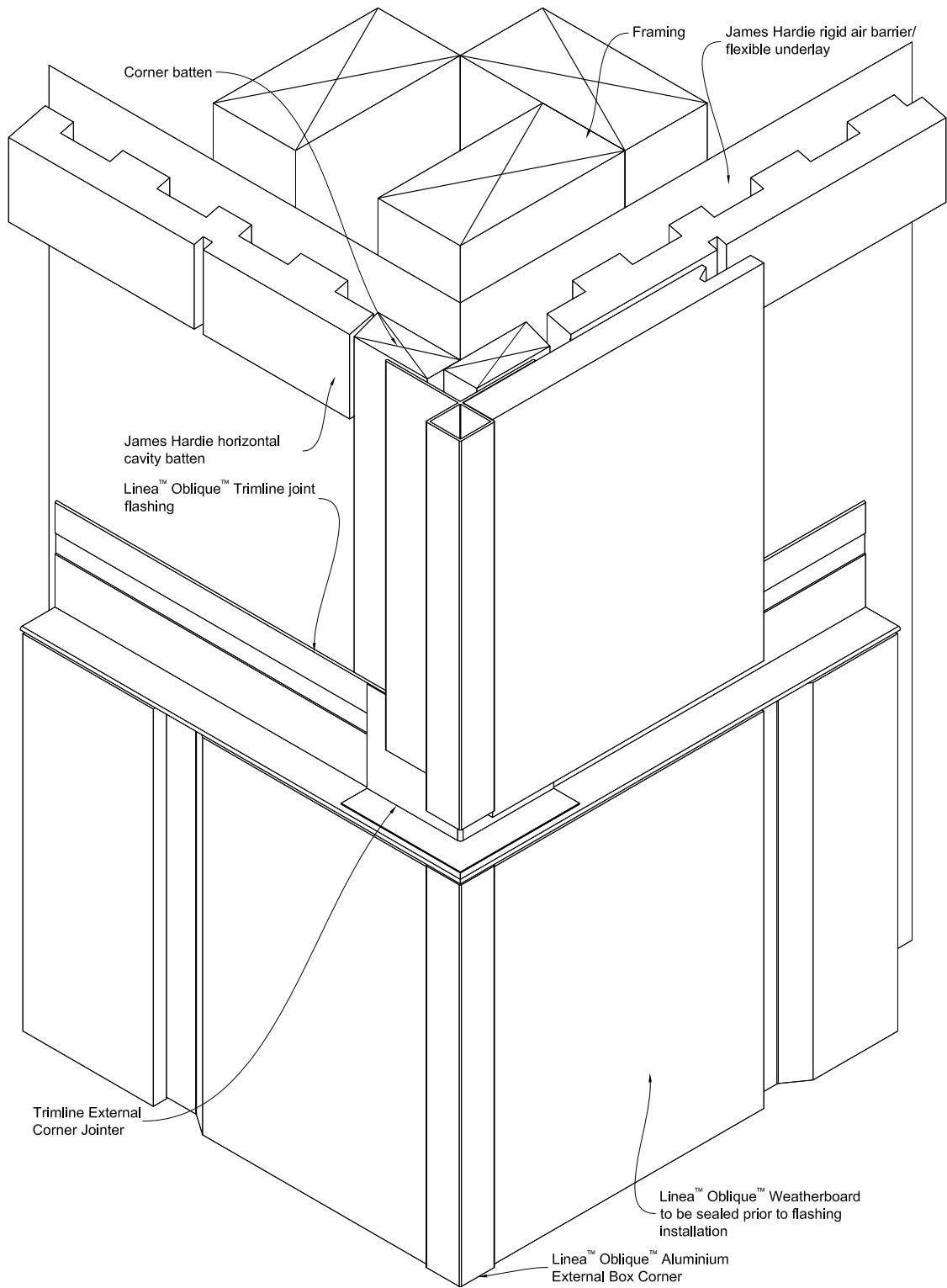

Figure 21: Trimline joint

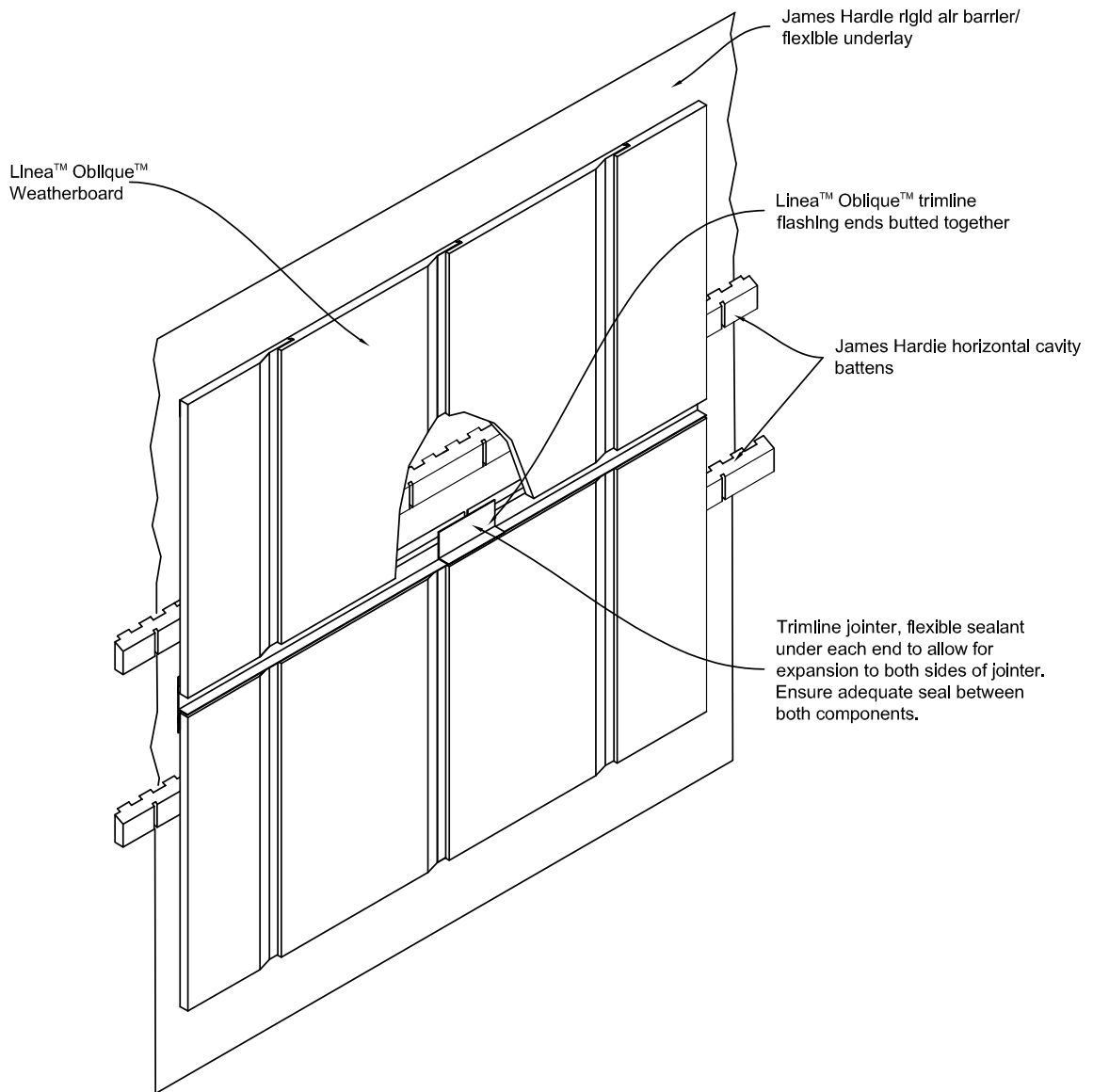
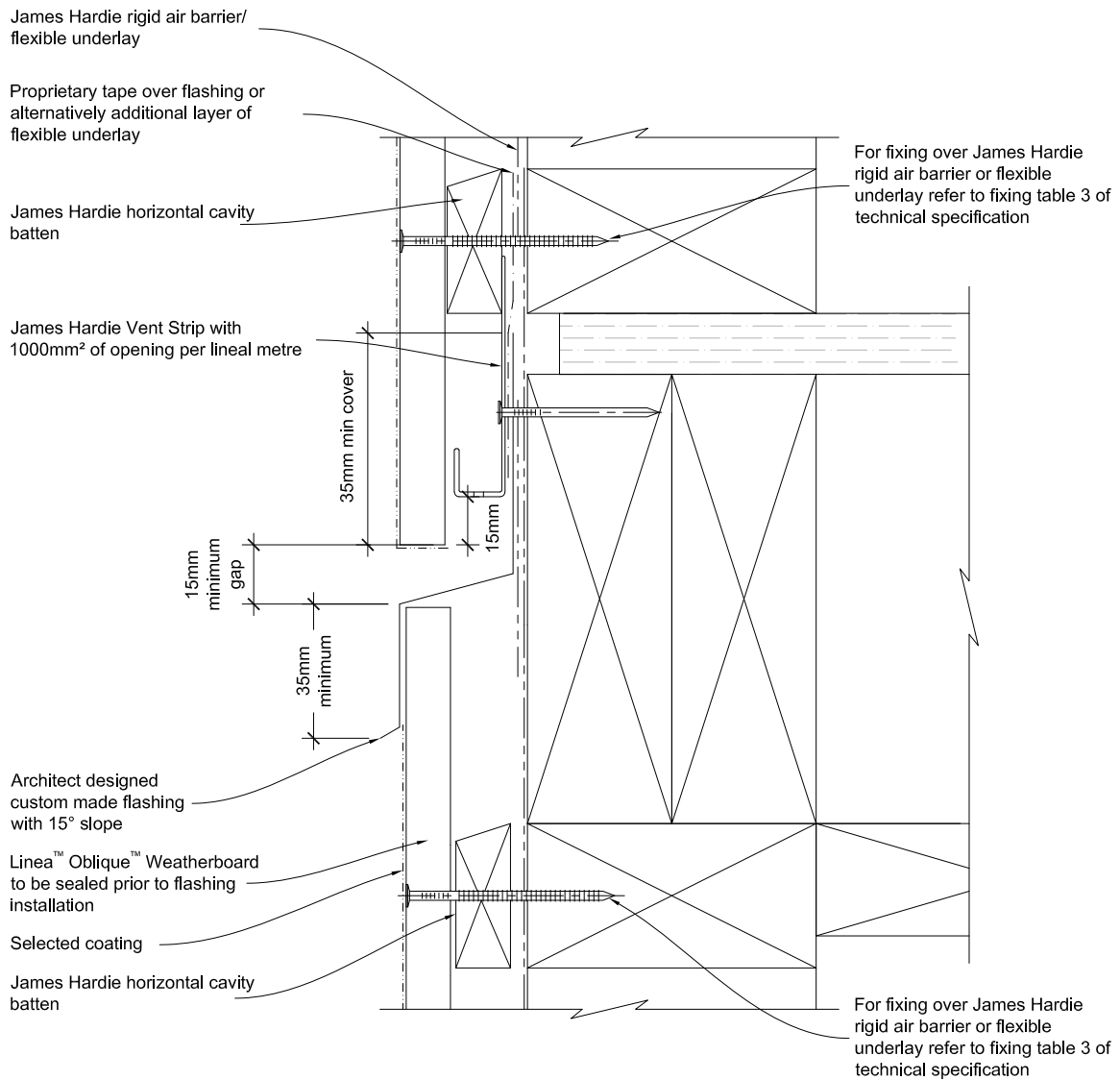

Figure 22: Drained flashing joint at floor level



Note:

This detail is required to limit cavities to a maximum of 2 stories or 7 metres
Refer to E2/AS1 clause 9.1.9.4

STEP 1

- Check architect's plans for the type of flashing to be used

STEP 2

- Check fixing centres and edge distances
- If top fixings are to be hidden by the Z flashing they will need to be fixed and sealed before the Z flashing is installed
- Cut edges need to be primed with Acraprime sealer or similar

STEP 3

- When 50 year durability is required refer Table 20 E2/AS1

STEP 4

- The flashing to be placed in the centre of the floor joists. Do not fix James Hardie horizontal cavity batten or cladding into floor joists

Figure 23: Drained flashing joint at floor joist

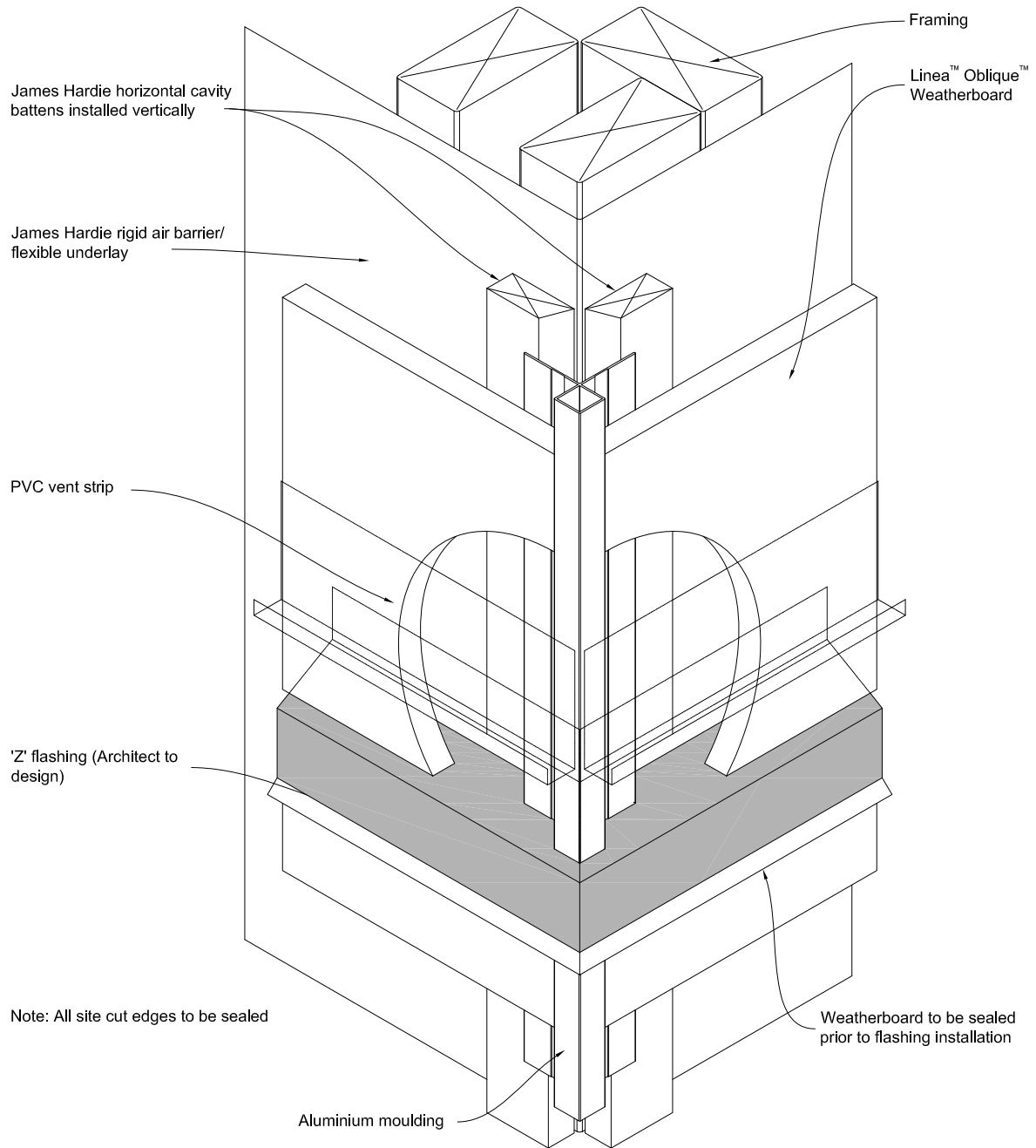

Figure 24: Apron flashing detail

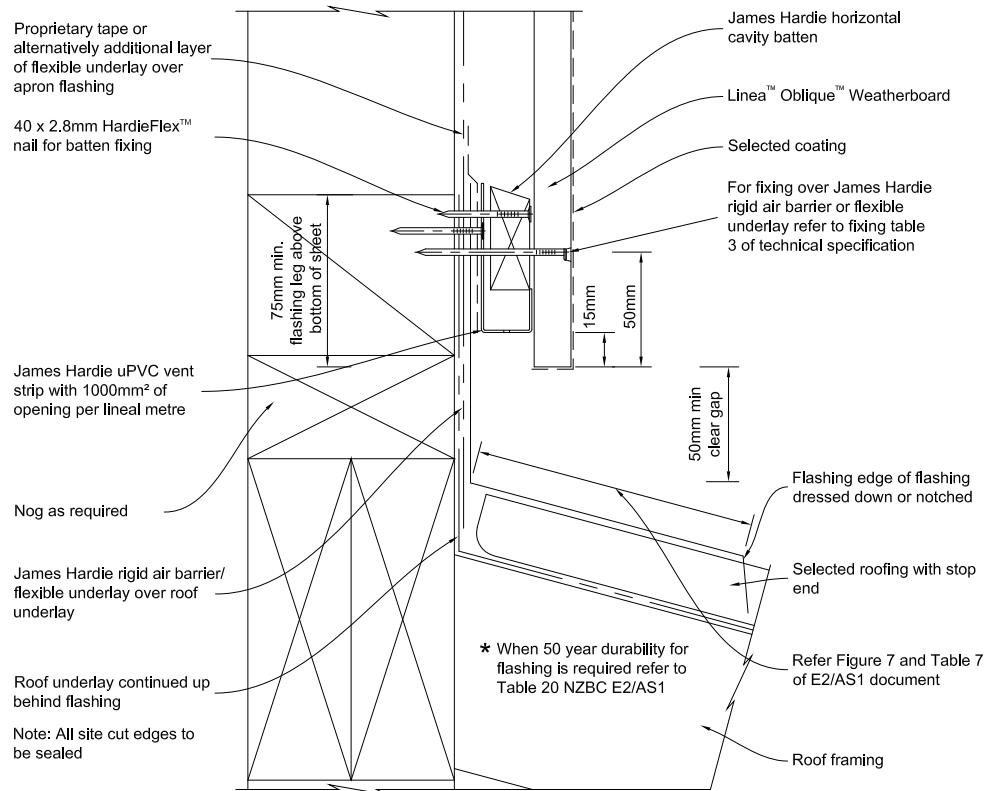

Figure 25: Parapet flashing

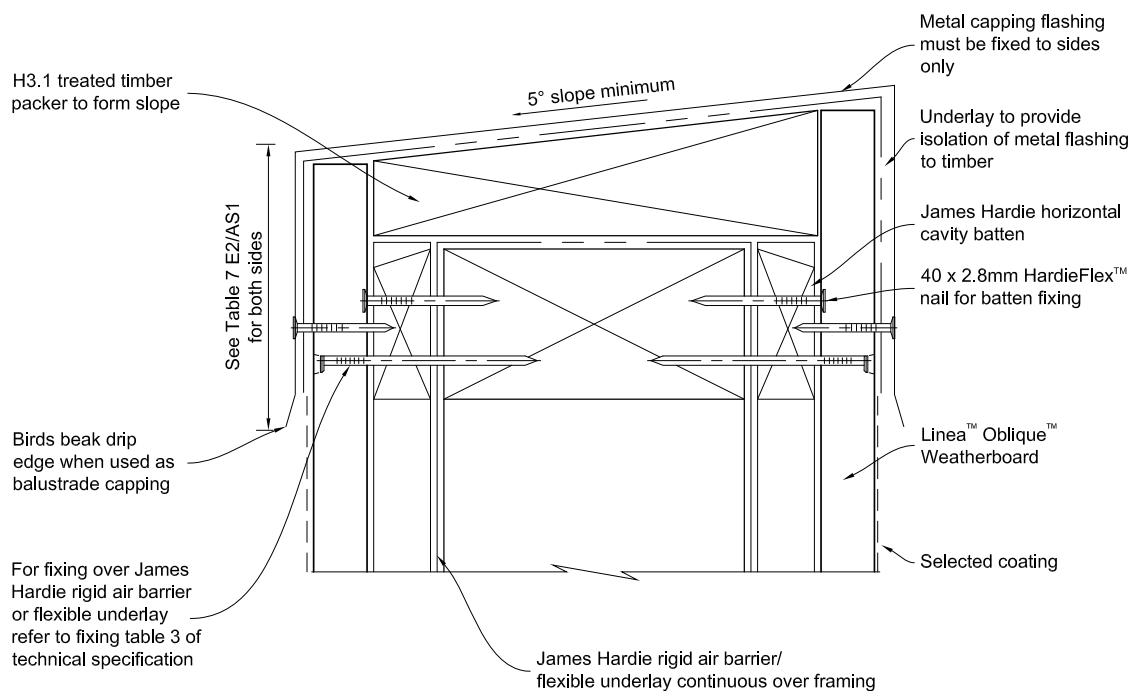

Figure 26: Roof to wall junction detail

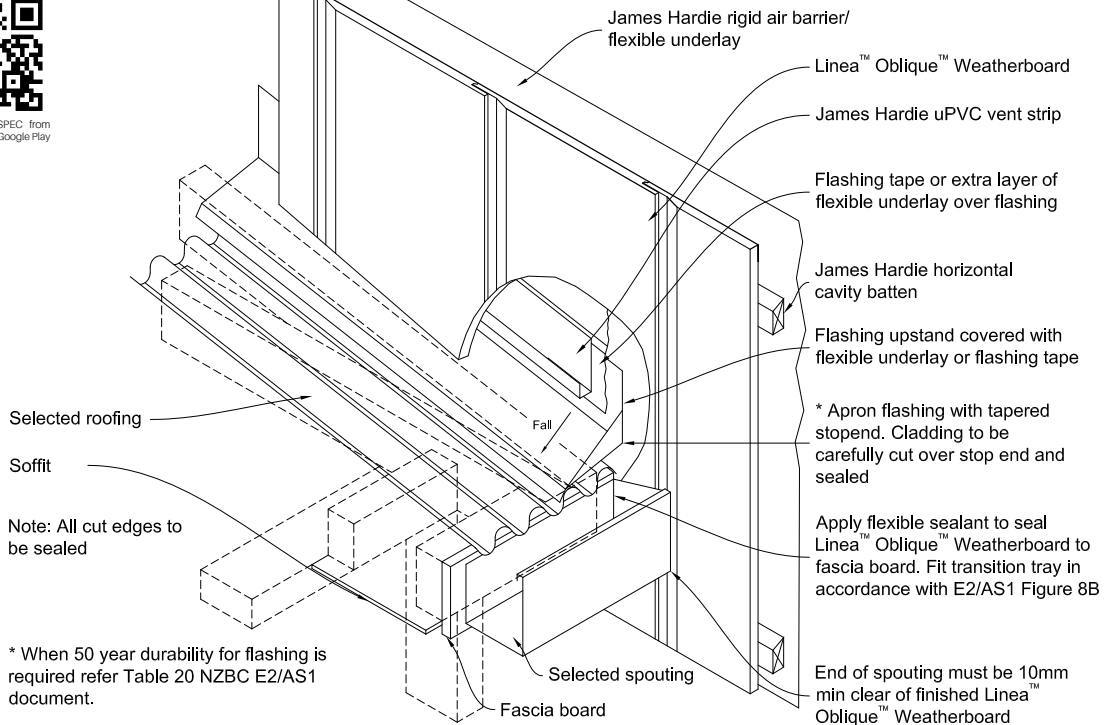

Figure 27: Meter box at sill

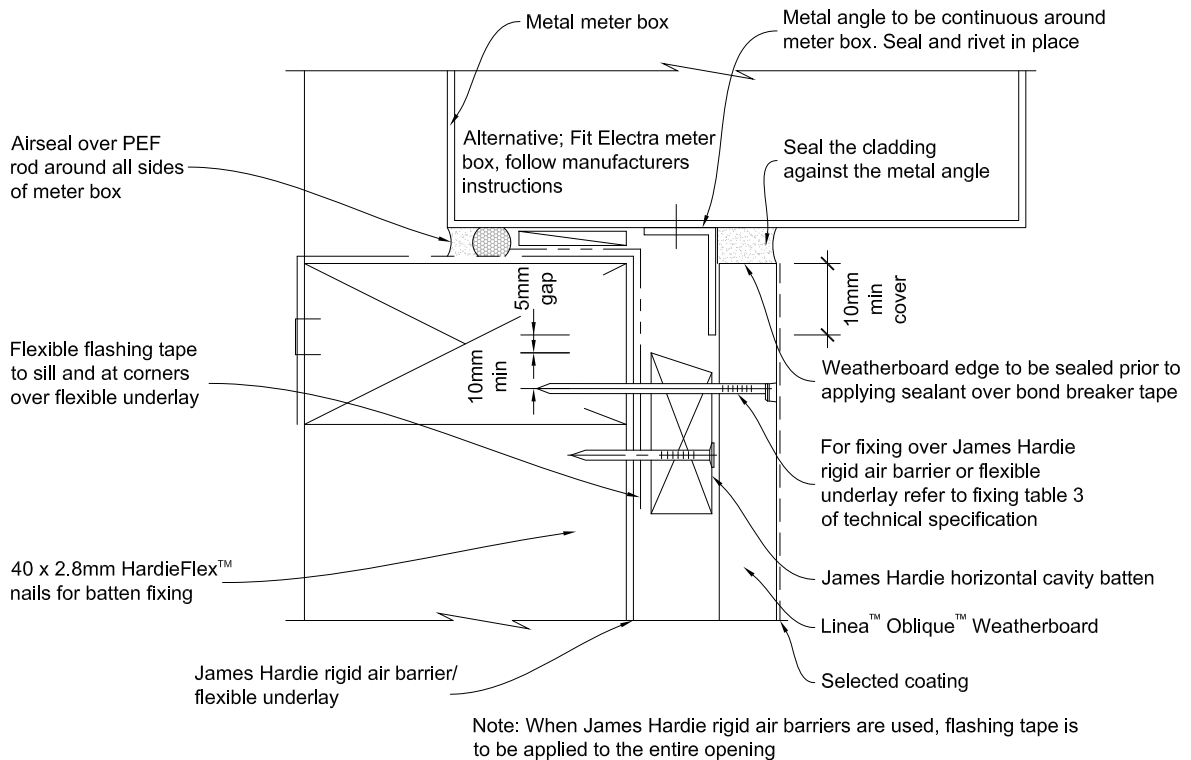

Figure 28: Meter box at jamb

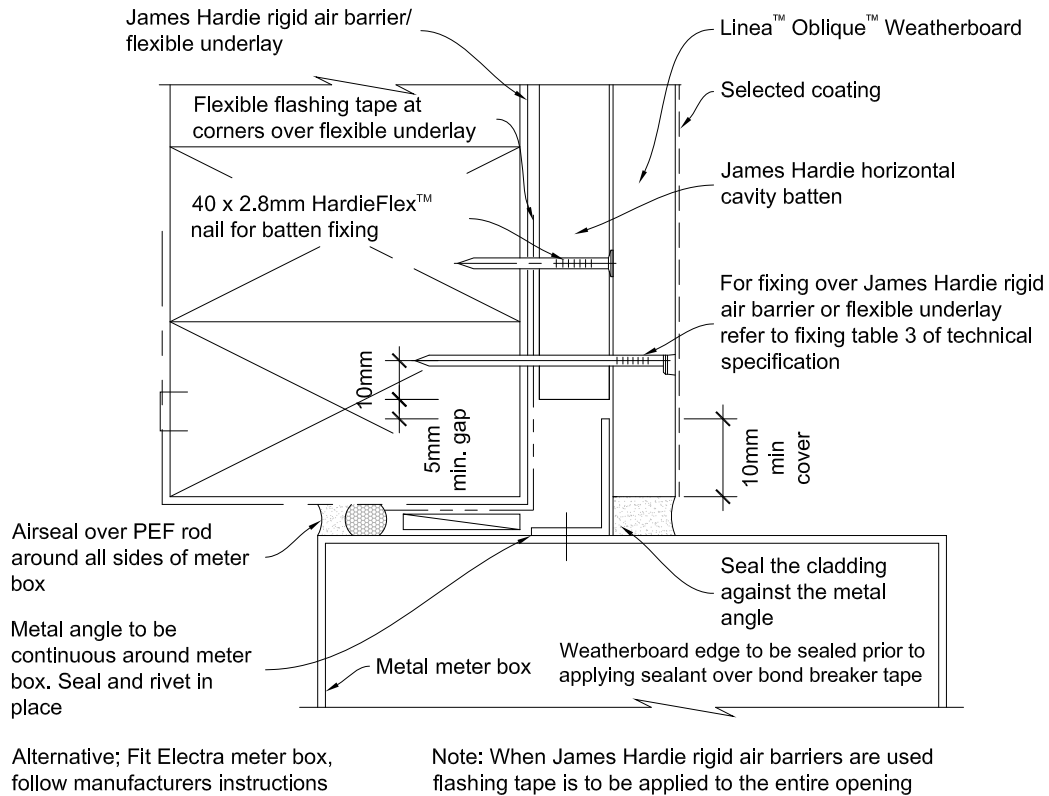

Figure 29: Meter box at head

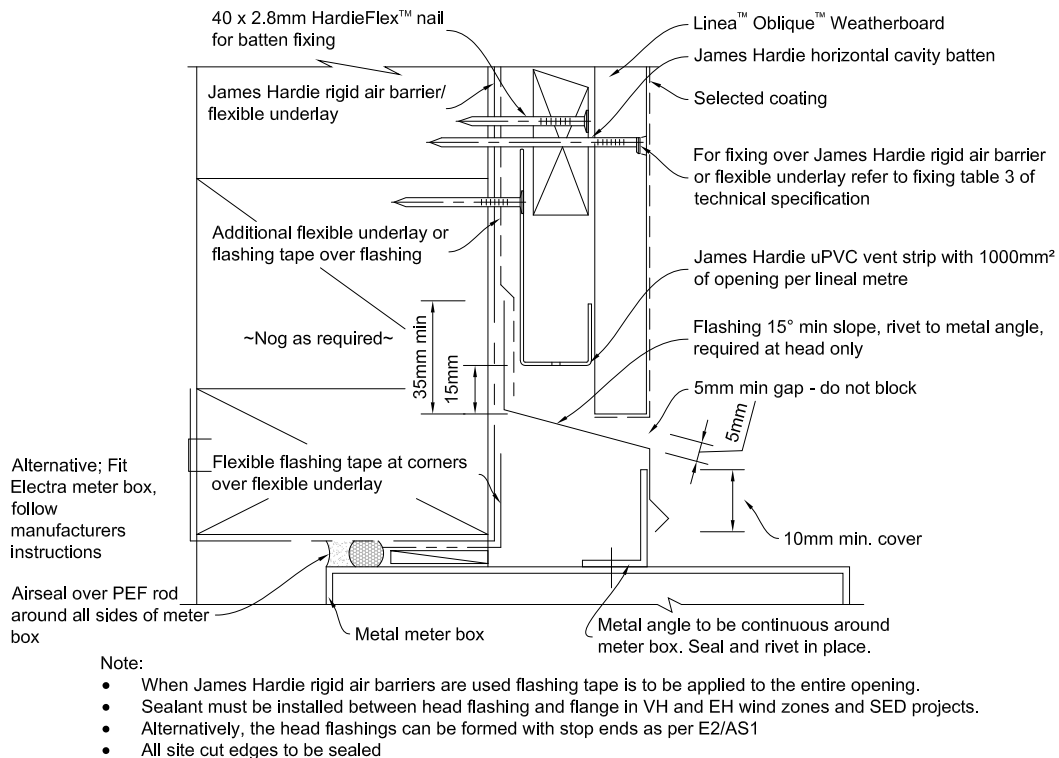

Figure 30: Enclosed deck

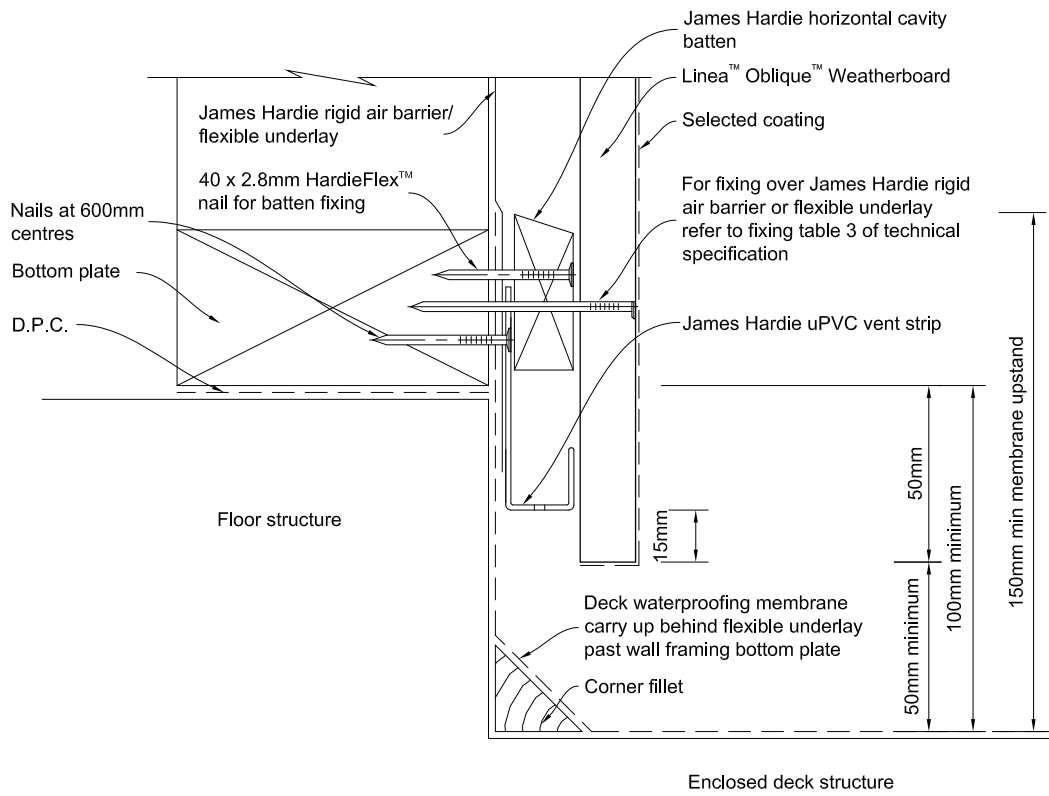

Figure 31: Pipe penetration

James Hardie rigid air barrier/
flexible underlay carefully cut
to suit pipe

Pipe to have min 5° fall to
outside

James Hardie horizontal
cavity batten

Linea™ Oblique™
Weatherboard over flashing
tape, carefully cut to suit
pipe and seal with flexible
sealant

Flexible flashing tape
bandage min 25mm wide all
round pipe

Square of flexible
flashing tape to a min
of 100mm outside of
pipe, ensure seal with
pipe bandage or
Marshall Innovation
Trade Seal

Notched batten

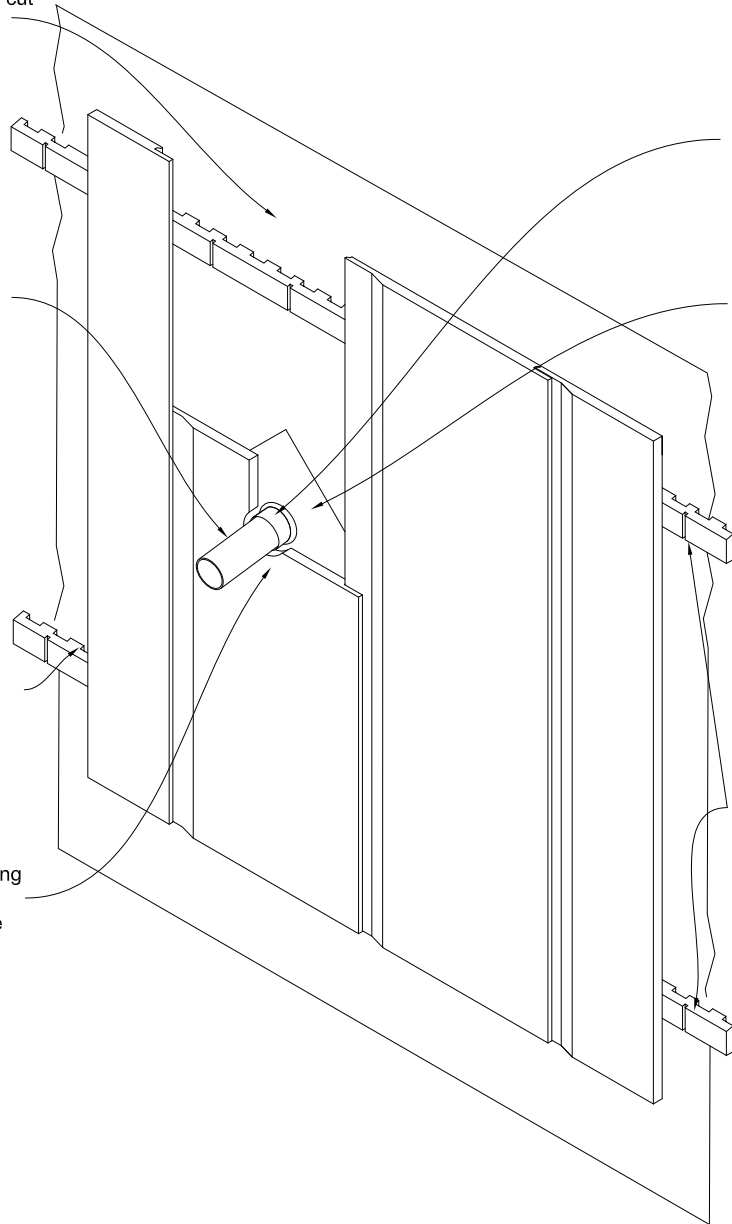

Figure 32: Cladding installed

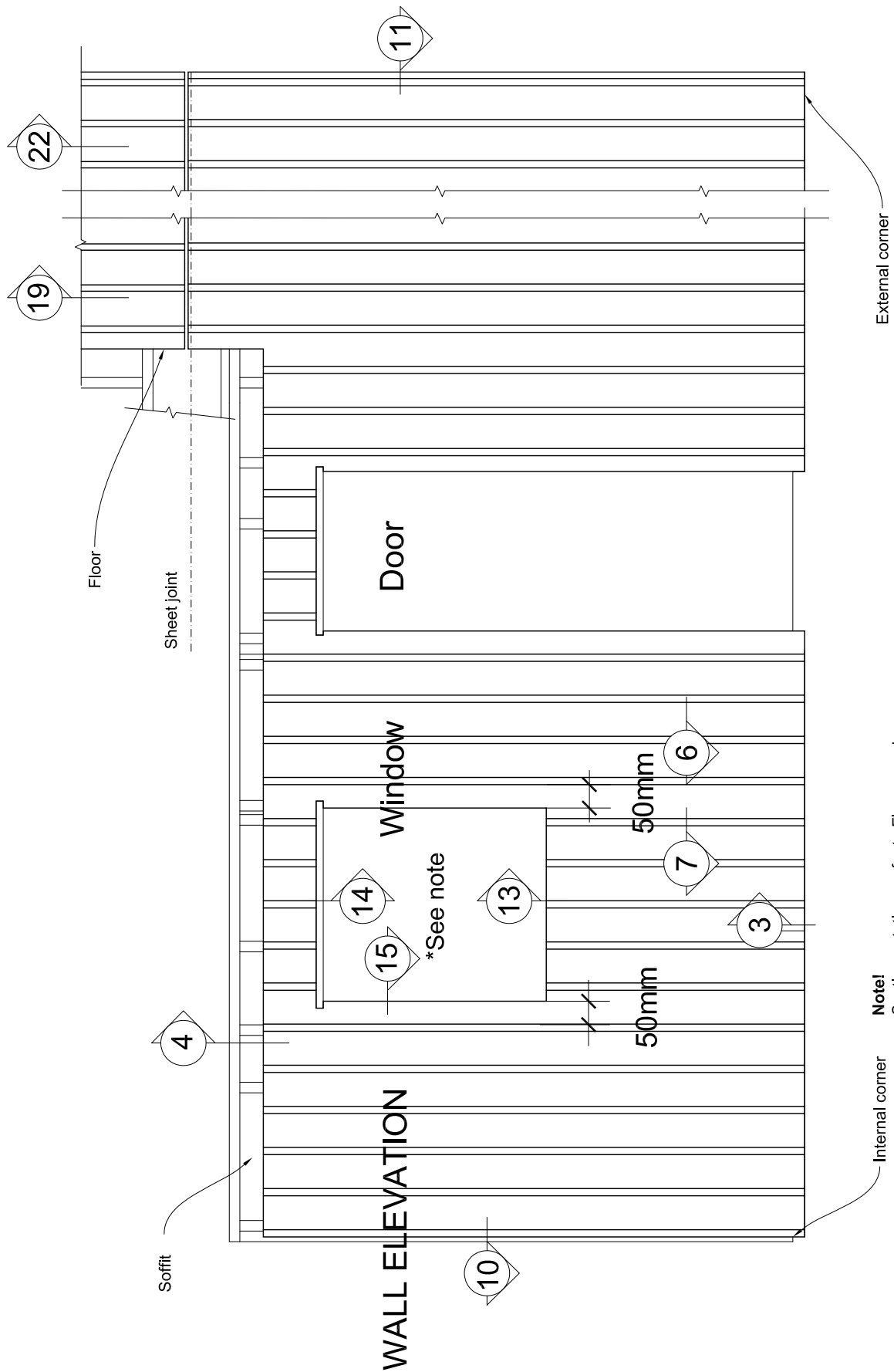

Figure 33: Garage head

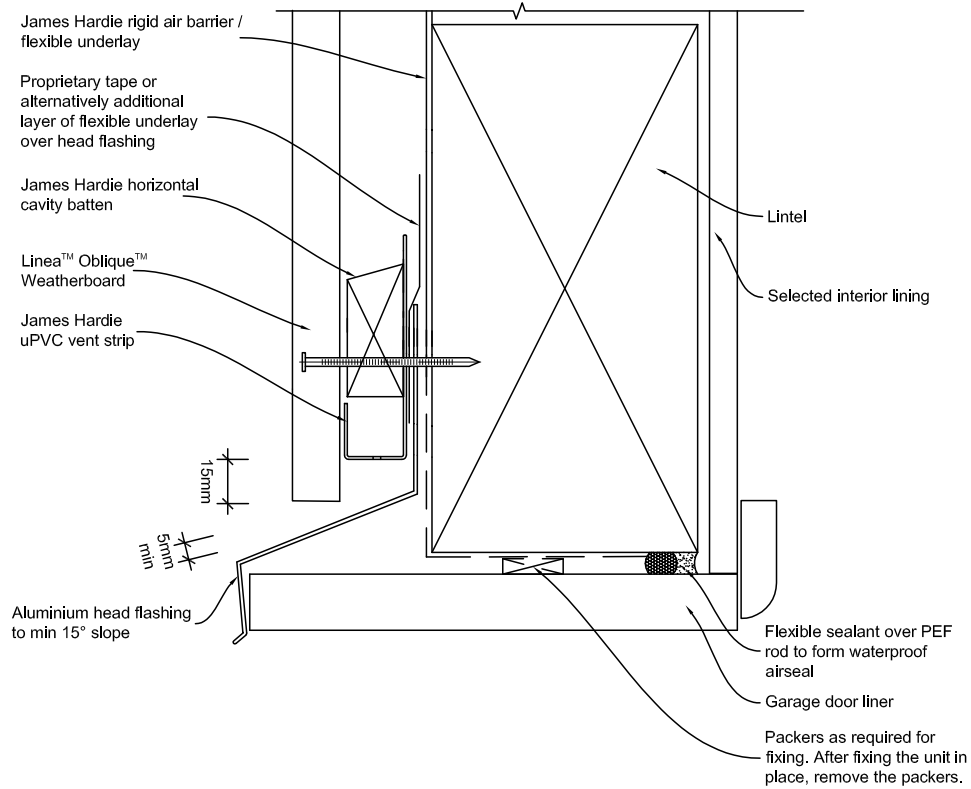
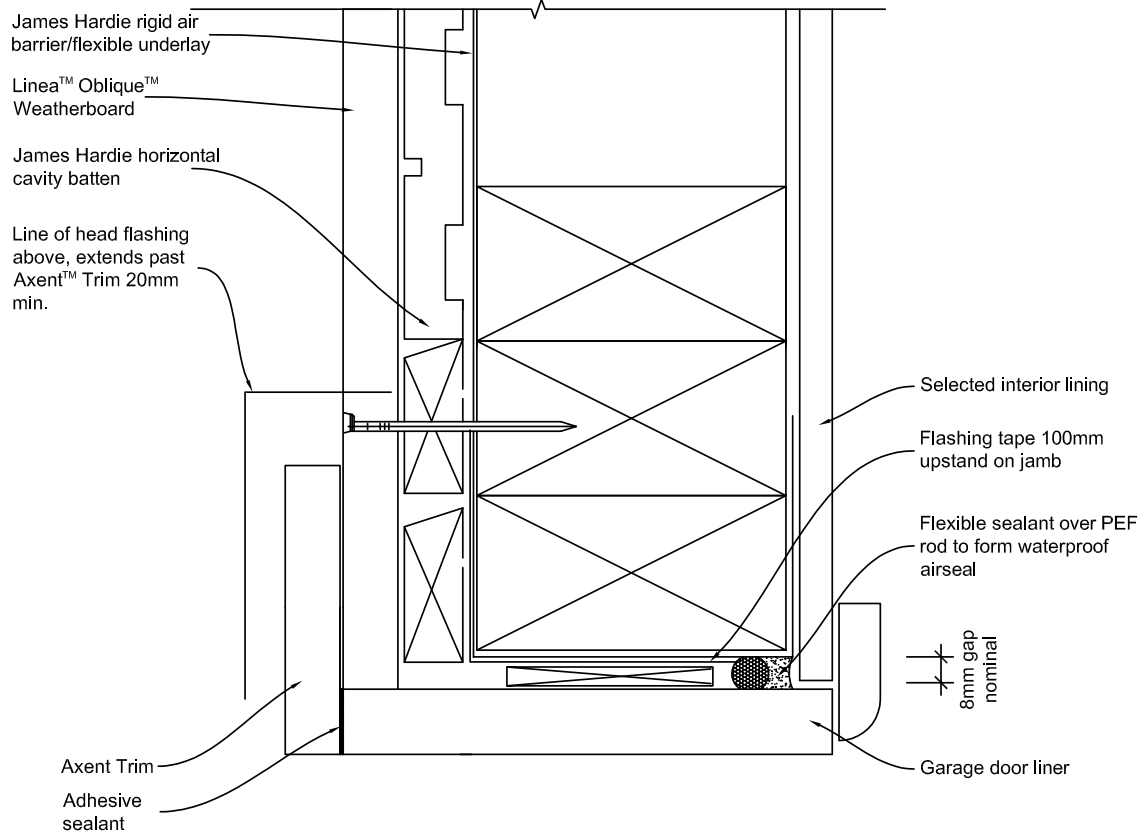

Figure 34: Garage jamb



Product Warranty



James Hardie New Zealand Limited (“James Hardie”) warrants for a period of 25 years from the date of purchase that the Linea™ Oblique™ Weatherboard (the “Product”), will be free from defects due to defective factory workmanship or materials and, subject to compliance with the conditions below, will be resistant to cracking, rotting, fire and damage from termite attacks to the extent set out in James Hardie’s relevant published literature current at the time of installation. James Hardie warrants for a period of 15 years from the date of purchase that the accessories supplied by James Hardie will be free from defects due to defective factory workmanship or materials.

Nothing in this document shall exclude or modify any legal rights a customer may have under the Consumer Guarantees Act or otherwise which cannot be excluded or modified at law.

CONDITIONS OF WARRANTY:

The warranty is strictly subject to the following conditions:

- a) James Hardie will not be liable for breach of warranty unless the claimant provides proof of purchase and makes a written claim either within 30 days after the defect would have become reasonably apparent or, if the defect was reasonably apparent prior to installation, then the claim must be made prior to installation;
- b) this warranty is not transferable;
- c) the Product must be installed and maintained strictly in accordance with the relevant James Hardie literature current at the time of installation and must be installed in conjunction with the components or products specified in the literature. Further, all other products, including coating and jointing systems, applied to or used in conjunction with the Product must be applied or installed and maintained strictly in accordance with the relevant manufacturer’s instructions and good trade practice;
- d) the project must be designed and constructed in strict compliance with all relevant provisions of the current New Zealand Building Code (“NZBC”), regulations and standards;
- e) the claimant’s sole remedy for breach of warranty is (at James Hardie’s option) that James Hardie will either supply replacement product, rectify the affected product or pay for the cost of the replacement or rectification of the affected product;
- f) James Hardie will not be liable for any losses or damages (whether direct or indirect) including property damage or personal injury, consequential loss, economic loss or loss of profits, arising in contract or negligence or howsoever arising. Without limiting the foregoing James Hardie will not be liable for any claims, damages or defects arising from or in any way attributable to poor workmanship, poor design or detailing, settlement or structural movement and/or movement of materials to which the Product is attached, incorrect design of the structure, acts of God including but not limited to earthquakes, cyclones, floods or other severe weather conditions or unusual climatic conditions, efflorescence or performance of paint/coatings applied to the Product, normal wear and tear, growth of mould, mildew, fungi, bacteria, or any organism on any Product surface or Product (whether on the exposed or unexposed surfaces);
- g) all warranties, conditions, liabilities and obligations other than those specified in this warranty are excluded to the fullest extent allowed by law;
- h) if meeting a claim under this warranty involves re-coating of Products, there may be slight colour differences between the original and replacement Products due to the effects of weathering and variations in materials over time.

Disclaimer: The recommendations in James Hardie’s literature are based on good building practice, but are not an exhaustive statement of all relevant information and are subject to conditions (c), (d), (f) and (g) above. Linea™ Oblique™ Weatherboard has been appraised by BRANZ as an alternative solution and found to meet the required provisions of the NZBC when installed in accordance with the Linea™ Oblique™ Weatherboard Vertical Installation technical specification. However, as the successful performance of the relevant system depends on numerous factors outside the control of James Hardie (e.g. quality of workmanship and design) James Hardie shall not be liable for the recommendations made in its literature and the performance of the relevant system, including its suitability for any purpose or ability to satisfy the relevant provisions of the NZBC, regulations and standards, as it is the responsibility of the building designer to ensure that the details and recommendations provided in the relevant James Hardie installation manual are suitable for the intended project and that specific design is conducted where appropriate.

Copyright April 2019 © James Hardie New Zealand Limited. TM and ® denotes a Trademark or Registered Mark owned by James Hardie Technology Limited.

