



ASSESSMENT REPORT

The likely fire resistance performance of linear gap sealing systems in aerated concrete walls and floors if tested in accordance with AS1530.4-2005

EWFA Report No:

23715-02

Report Sponsor:

Sika Australia Pty Limited
55 Elizabeth Street
Wetherill Park, NSW 2164

DOCUMENT REVISION STATUS

Date Issued	Issue No	Description
29/10/2009	23715-00	Initial Issue
13/1/2010	23715-01	Revised to include drawing of specimen
14/1/2010	23715-02	Typographical amendment

CONTACT INFORMATION

Exova Warringtonfire Aus Pty Ltd - ABN 81 050 241 524

NATA Registered Laboratory

Unit 2, 409-411 Hammond Road
Dandenong Victoria 3175
Australia

T: +61 (0)3 9767 1000
F: +61 (0)3 9767 1001

New South Wales

Suite 2002a, Level 20,
44 Market Street
Sydney NSW 2000
Australia

T: +61 (0)2 8270 7600
F: +61 (0)2 9299 6076

Victoria

Unit 2, 409-411 Hammond Road
Dandenong Victoria 3175
Australia

T: +61 (0)3 9767 1000
F: +61 (0)3 9767 1001

Queensland

Northpoint, Unit 12, Level 3
231 North Quay
Brisbane QLD 4000
Australia

T: +61 (0)7 3238 1700
F: +61 (0)7 3211 4833

CONTENTS

1	INTRODUCTION	4
2	TESTED PROTOTYPES	4
3	VARIATION TO TESTED PROTOTYPES	4
4	REFERENCED TEST PROCEDURES	4
5	FORMAL ASSESSMENT SUMMARY	5
6	DIRECT FIELD OF APPLICATION	6
7	REQUIREMENTS	6
8	VALIDITY	7
9	AUTHORITY	7
9.1	Applicant Undertakings and Conditions of Use	7
9.2	General Conditions of Use	7
9.3	Authorisation on Behalf of Exova Warringtonfire Aus Pty Ltd	8
9.4	Date of Issue	8
9.5	Expiry Date	8
APPENDIX A	- SUMMARY OF SUPPORTING DATA	9
A.1	Test Report – WF 182095	9
A.2	Likely Performance if Tested in accordance with AS1530.4-2005	11
APPENDIX B	- ASSESSMENT OF SPECIFIC VARIATIONS	13
B.1	Likely Performance if Tested in accordance with AS1530.4-2005	13

1 INTRODUCTION

This report presents an assessment of the likely fire resistance performance of linear gap sealing systems in aerated concrete walls and floors if tested in accordance with AS1530.4-2005.

The tested prototypes described in Section 2 of this report, when subject to the proposed variations described in Section 3, are to perform satisfactorily if tested in accordance with the referenced test method described in Section 4. The conclusions of the report are summarised in Section 5.

The validity of this assessment is conditional on compliance with Sections 7, 8 and 9 of this report.

Summaries of the test data on which this assessment is based are provided in Appendix A. A summary of the critical issues leading to the assessment conclusions including the main points of argument are included in Appendix B.

2 TESTED PROTOTYPES

This assessment is based on test report WF 182095 from the Bodycote Warringtonfire, UK which describes a fire resistance test performed on various linear gap sealing systems when installed in gaps within aerated concrete wall and floor slab.

Permission has been granted from Sika Australia Pty. Ltd for the data to be used in the preparation of this report.

For the purpose of this report, data considered from this fire resistance test is summarised in Appendix A

3 VARIATION TO TESTED PROTOTYPES

The proposed construction shall be as tested in WF 182095 with consideration given to the likely performance in accordance with AS 1530.4-2005.

4 REFERENCED TEST PROCEDURES

This report is prepared with reference to the requirements of AS1530.4-2005 and AS4072.1-2005 for the determination of a FRL.

5 FORMAL ASSESSMENT SUMMARY

On the basis of the discussion presented in this report, it is the opinion of this testing authority that if the tested prototypes described in Section 2 had been varied as in Section 3, they would have been likely to achieve the fire resistance performances below if tested in accordance with the test method referenced in Section 4 and subject to the requirements of Section 7.

Table 1: Likely fire resistance performance for Autoclaved Aerated Concrete Walls 670kg/m³

ID	Wall Thick. (mm)	Gap Width (mm)	Seal depth (mm)	Sealant (item 1)	Backing Material (Item 2)	Seal Location	FRL
A	250	15	250	SikaBoom-F/ SikaBoom-FR	None	Both faces	-/240/240
B	250	20	180		Exposed	-/180/180	
C	250	45	60		Rockwool (110kg/m ³ friction fit)	Both faces	-/240/240
D	250	30	80		Both faces	-/240/240	
E	250	15	150		None	Exposed	-/120/120

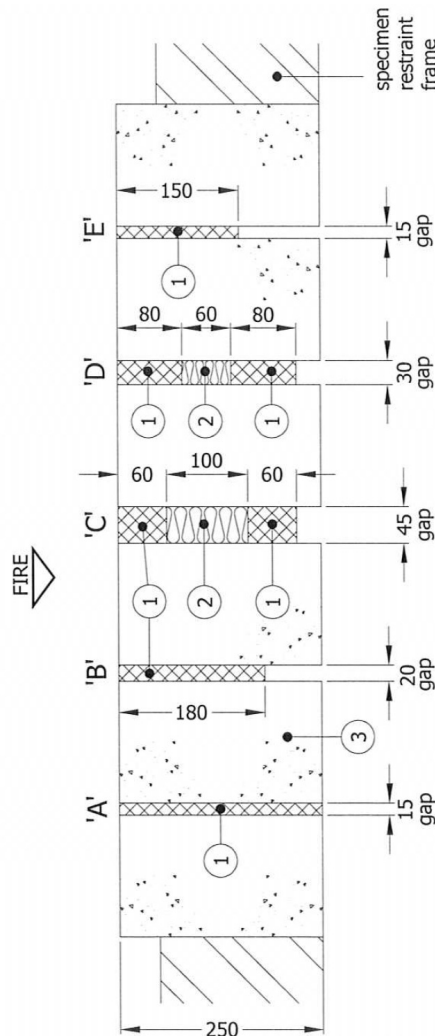
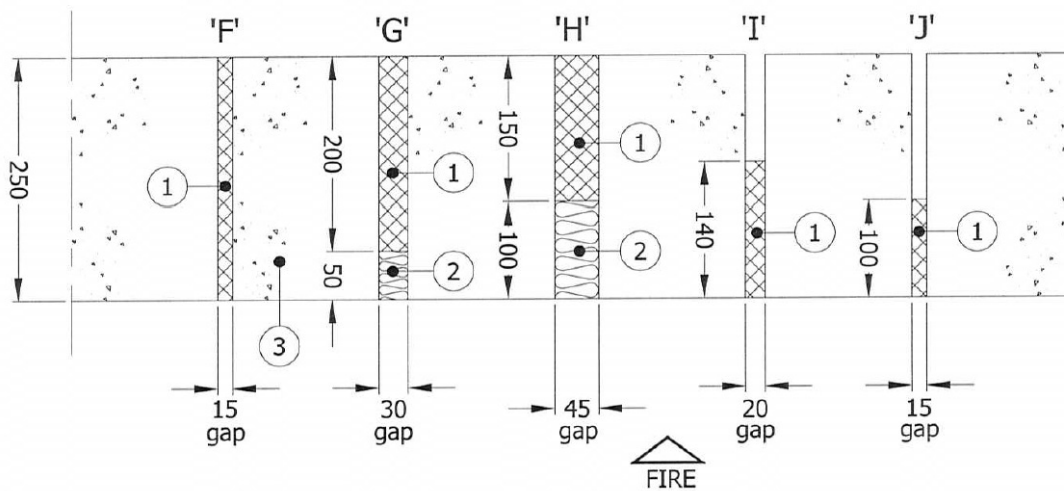

Table 2: Likely fire resistance performance for Autoclaved Aerated Concrete Floor

ID	Floor Thick. (mm)	Gap Width (mm)	Seal depth (mm)	Sealant Reference (Item 1)	Backing Material (Item 2)	Seal Location	FRL
F	250	15	250	SikaBoom-F/ SikaBoom-FR	None	Both faces	-/240/240
G	250	30	200		Rockwool (110kg/m ³ friction fit)	Unexposed	-/240/240
H	250	45	150		Unexposed	-/240/240	
I	250	20	140		Exposed	-/60/60	
J	250	15	100		Exposed	-/30/30	



6 DIRECT FIELD OF APPLICATION

The results of this assessment are applicable to walls exposed to fire from one side or exposed to fire from both sides (for symmetric systems) and floors exposed to fire from underside only.

7 REQUIREMENTS

This report details the methods of construction, test conditions and assessed results that would have been expected had the specific elements of construction described herein been tested in accordance with AS 1530.4-2005.

The supporting wall and floor construction shall be capable of providing effective support of the proposed construction for the required fire resistance period (FRL).

Any further variations with respect to size, constructional details, loads, stresses, edge or end conditions, other than those identified in this report, may invalidate the conclusions drawn in this report.

8 VALIDITY

This assessment report does not provide an endorsement by Exova Warringtonfire Aus Pty Ltd of the actual products supplied.

The conclusions of this assessment may be used to directly assess the fire resistance performance under such conditions, but it should be recognised that a single test method will not provide a full assessment of the fire hazard under all fire conditions.

Because of the nature of fire resistance testing, and the consequent difficulty in quantifying the uncertainty of measurement, it is not possible to provide a stated degree of accuracy. The inherent variability in test procedures, materials and methods of construction, and installation may lead to variations in performance between elements of similar construction.

The assessment can therefore only relate only to the actual prototype test specimens, testing conditions and methodology described in the supporting data, and does not imply any performance abilities of constructions of subsequent manufacture. This assessment is based on information and experience available at the time of preparation. The published procedures for the conduct of tests and the assessment of test results are the subject of constant review and improvement and it is recommended that this report be reviewed on or, before, the stated expiry date.

The information contained in this report shall not be used for the assessment of variations other than those stated in the conclusions above. The assessment is valid provided no modifications are made to the systems detailed in this report.

All details of construction should be consistent with the requirements stated in the relevant test reports and all referenced documents.

9 AUTHORITY

9.1 APPLICANT UNDERTAKINGS AND CONDITIONS OF USE

By using this report as evidence of compliance or performance, the applicant(s) confirms that:

- to their knowledge the component or element of structure, which is the subject of this assessment, has not been subjected to a fire test to the Standard against which this assessment is being made, and
- they agree to withdraw this assessment from circulation should the component or element of structure be the subject of a fire test by a test authority in accordance with the Standard against which this assessment is being made and the results are not in agreement with this assessment, and
- they are not aware of any information that could adversely effect the conclusions of this assessment and if they subsequently become aware of any such information, agree to ask the assessing authority to withdraw the assessment.

9.2 GENERAL CONDITIONS OF USE

This report may only be reproduced in full without modifications by the report sponsor. Copies, extracts or abridgments of this report in any form shall not be published by other organisations or individuals without the permission of Exova Warringtonfire Aus Pty Ltd.

9.3 AUTHORISATION ON BEHALF OF EXOVA WARRINGTONFIRE AUS PTY LTD

Prepared By



K. Nicholls

Reviewed by:

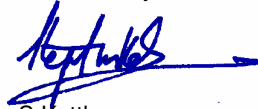

S Kettle

9.4 DATE OF ISSUE

14th January 2010

9.5 EXPIRY DATE

31st October 2014

APPENDIX A - SUMMARY OF SUPPORTING DATA

A.1 TEST REPORT – WF 182095

A.1.1 Report Sponsor

A.1.1.1 Sika Services AG, Tüffenwies 16, CH-8048 Zürich, Switzerland.

A.1.2 Test Laboratory

A.1.2.1 Bodycote Warringtonfire, Holmesfield Road, Warrington, WA1 2DS, UK.

A.1.3 Test Date

A.1.3.1 The test was conducted on 12 January 2007

A.1.4 Test standards prescribed

A.1.4.1 The test was conducted using the heating conditions and performance criteria described in BS 476: Part 20: 1987

A.1.5 Variations to Test Standard

A.1.5.1 None

A.1.6 Description of Tested Assembly

A.1.6.1 Five wall (referenced A, B, C, D & E) and five floor (referenced F, G, H, I & J) specimens of linear gap sealing systems were tested. The section of wall had overall dimensions of 1000mm long by 1000 wide by 250mm thick; the section of floor had overall dimensions of 1200mm high by 1200mm wide by 250mm thick. All of the gaps were sealed on the exposed and non-exposed sides.

A.1.6.2 Material specification is given below:

Sealant: SikaBoom-F/SikaBoom-FR, 1K Polyurethane (PUR) nozzle foam HFC-free, nozzle applied

Backing Material Insulation: Rockwool (RPB-12), 110 kg/m³, friction fit.

Concrete Wall/Floor: Autoclaved aerated concrete, 670kg/m³, 250mm thick.

The specimens referred above are as follows:

ID	Wall Thick. (mm)	Gap Width (mm)	Seal depth (mm)	Sealant Reference	Backing Material	Seal Positions
A	250	15	250	SikaBoom-F/ SikaBoom-FR	None	Both faces
B	250	20	180	SikaBoom-F/ SikaBoom-FR	None	Exposed
C	250	45	60	SikaBoom-F/ SikaBoom-FR	Rockwool	Both faces
D	250	30	80	SikaBoom-F/ SikaBoom-FR	Rockwool	Both faces
E	250	15	150	SikaBoom-F/ SikaBoom-FR	None	Exposed
F	250	15	250	SikaBoom-F/ SikaBoom-FR	None	Both faces
G	250	30	200	SikaBoom-F/ SikaBoom-FR	Rockwool	Unexposed
H	250	45	150	SikaBoom-F/ SikaBoom-FR	Rockwool	Unexposed
I	250	20	140	SikaBoom-F/ SikaBoom-FR	None	Exposed
J	250	15	100	SikaBoom-F/ SikaBoom-FR	None	Exposed

Seals B, C, D, and E were recessed into the gap in the wall.
Seals I and J were recessed into the floor.

A.1.7 Test Results

The test was discontinued after 300 minutes and the specimens satisfied the performance criteria (maximum temperature) specified in BS 476: Part 20: 1987 for the following period:

Specimen	Time to failure in minutes	
	Insulation	Integrity
A	300*	300*
B	193	193
C	300*	300*
D	300*	300*
E	183	183
F	300*	300*
G	300*	300*
H	300*	300*
I	88	87
J	59	59

No failure observed up to this time.

A.2 LIKELY PERFORMANCE IF TESTED IN ACCORDANCE WITH AS1530.4-2005

A.2.1 General

A.2.1.1 The fire resistance test WF 182095 was conducted in using the heating conditions and performance criteria described in BS: 476: Part 20, which differs from AS1530.4 2005. The significance of these differences is discussed below.

A.2.2 Discussion

Temperature Regime

A.2.2.1 The furnace temperature regime for fire resistance tests conducted in accordance with AS 1530.4-2005 follows the same trend as BS: 476: Part 20: 1987.

A.2.2.2 The parameters outlining the accuracy of control of the furnace temperature in AS 1530.4-2005 and BS: 476: Part 20: 1987 are not appreciably different.

Furnace Thermocouples

A.2.2.3 The furnace thermocouples specified in AS1530.4-2005 are type K, mineral insulated metal sheathed (MIMS) with a stainless steel sheath having a wire of diameter of less than 1.0mm and an overall diameter of 3mm. The measuring junction protrudes at least 25mm from the supporting heat resistant tube.

A.2.2.4 The furnace thermocouple types in BS 476: Part 20: 1987 shall be one of the following two types:

- Bare nickel chromium/nickel aluminium wires, 0.75mm to 1.5mm in diameter, welded or crimped together at their ends and supported and insulated from each other in a twin bore porcelain insulator except that the wires for 25mm approximately from the weld/crimp shall be exposed and separated from each other by at least 5mm. (replace or recalibrate after 6hrs of usage).
- Nickel chromium/nickel aluminium wire contained within a mineral insulation and in a heat resisting steel sheath of diameter 1.5mm, the hot junctions being electrically insulated from the sheath. The thermocouple hot junction shall project 25mm from a porcelain insulator. The assembly shall have a response time on cooling in air of not greater than 30s.

A.2.2.5 The relative location of the furnace thermocouples to the exposed face of the specimen, for both AS1530.4-2005 and BS 476: Part 20: 1987, is 100mm \pm 10mm.

A.2.2.6 The variations in furnace thermocouples specification and responses are not considered to have significant effect on the outcome of the referenced fire resistance test.

Specimen Thermocouples

A.2.2.7 For penetration sealing systems, BS 476: Part 20 has no specific provision for the location of thermocouples, whereas AS1530.4-2005 has specific requirements for the application of thermocouples.

A.2.2.8 AS1530.4-2005 specifies thermocouple locations for linear gap seals (control joints), as follows:

- At least three on the surface of the seal, with one thermocouple for each 0.3 m² of surface area, up to a maximum of five, uniformly distributed over the area (one thermocouple being located at the centre of the seal).
- On the surface of the seal 25 mm from the edge of the opening, with one thermocouple for each 500 mm of the perimeter.
- On the surface of the separating element 25 mm from the edge of the opening, with one thermocouple for each 500 mm of the perimeter.

A.2.2.9 In the reference test the thermocouples are not located in strict accordance with the requirements of AS1530.4-2005. The influence this has on the results of the test is discussed in on a case by case basis in Appendix B.

Furnace Pressure

- A.2.2.10 It is the requirement of AS1530.4-2005 that a pressure of 20 ± 3 Pa be maintained at the top of vertical linear gap seal that is greater than 1m in length and a pressure of 20 ± 3 Pa be maintained in a horizontal plane 100 ± 10 mm below the underside of the floor slab for horizontal linear gap seal
- A.2.2.11 For BS 476: Part 20: 1987 a neutral axis is maintained at a height of 1m from the notional floor level, subject to a pressure of 20Pa maintained in a horizontal plane 100 ± 10 mm below the a soffit.
- A.2.2.12 Test report WF 182095 shows that pressure was between 18 Pa and 20 Pa at a point 100mm below the soffit of the floor assembly. Therefore the furnace pressure in the test satisfies the requirements of AS1530.4:2005.

Specimen Size

- A.2.2.13** It is the requirement of AS1530.4-2005 that a control joint specimen be at least 1m long, this requirement has not been met by the specimen tested in WF 182095, The influence this has on the results is considered on a case by case basis in Appendix B.

Criteria of Failure

- A.2.2.14 AS1530.4-2005 specifies the following performance criteria for linear gap sealing systems (control joints):

Structural Adequacy:

Not applicable

Integrity:

- A.2.2.15 Failure in relation to integrity shall be deemed to have occurred if the specimen:
- Collapses,
 - Sustained flaming on the non-fire side in excess of 10 seconds,
 - Ignition of cotton pad within 30 seconds when applied.

Insulation:

- A.2.2.16 Failure in relation to insulation shall be deemed to have occurred when the temperature of any of the relevant thermocouples attached to the unexposed face of the test specimen rises by more than 180 K above the initial temperature.
- A.2.2.17 The integrity and insulation criteria specified in BS476: Part 20: 1987 are not appreciably different from AS1530.4:2005.

A.2.3 Application of Test Data from WF 182095 to AS1530.4 -2005.

- A.2.3.1 The likely effects of the location and number of thermocouples, and the length of the linear gap seals, are discussed on a case by case basis in Appendix B.
- A.2.3.2 In absence of further significant variations in testing procedure, it is considered that the results relating to the integrity and insulation performance of the tested penetrations in WF 182095 can be used to assess FRL's in accordance with AS1530.4-2005 and AS4072.1-2005, as discussed in Appendix B.

APPENDIX B - ASSESSMENT OF SPECIFIC VARIATIONS

B.1 LIKELY PERFORMANCE IF TESTED IN ACCORDANCE WITH AS1530.4-2005

B.1.1 Proposal

B.1.1.1 It is proposed that the test data in WF 182095 be used to support the likely fire resistance in accordance with AS1530.4-2005.

B.1.2 Discussion

Thermocouple Locations Wall and Floor Specimen

B.1.2.1 AS1530.4-2005 requires at least 3 thermocouples on the seal surface and one thermocouple for every 500mm of perimeter of the separating element, 25mm from the gap edge

B.1.2.2 The vertical and horizontal specimens tested in WF 182095 (the test was a combined wall and floor test) had two thermocouples on the seal, one in the middle and one 100mm from the end of the seal and two adjacent thermocouples on the separating element.

B.1.2.3 By inspection of the results of the test and the proposed insulation performance, it is apparent that there is in most cases a significant safety margin represented by the difference between the recorded temperatures at the proposed time and the insulation criterion of a maximum rise of 180°C, as shown below in Table B1:

TABLE B1

ID	Element	Insulation Achieved in WF18095	Proposed Insulation Performance (mins)	Margin (mins)	Maximum Temperature of Specimen at Proposed Insulation Performance
A	Wall	300*	240	60	75°C
B		193	180	13	72°C
C		300*	240	60	59°C
D		300*	240	60	65°C
E		183	120	33	54°C
F	Floor	300*	240	60	79°C
G		300*	240	60	56°C
H		300*	240	60	56°C
I		88	60	28	30°C
J		59	30	29	24°C

*No failure observed up to this time.

B.1.2.4 Inspection of the results also indicates that the insulation performance of the specimen was exceeded by a sudden and drastic increase in temperature of the seal associated with an integrity breakdown of the seal.

B.1.2.5 These integrity events are recorded in the observations of the test report. The proposed insulation performance for each seal is before any observed gaps occurred in the seal.

- B.1.2.6 Based on the observed behaviour and the margin of insulation performance of the specimen, it is considered that the variations in number of thermocouples would not significantly affect the insulation performance of seals. Further confidence in this proposal is provided by the margin over failure of the proposed insulation performance shown in Table B1 and the integrity driven insulation failure.

Thermocouple Locations on the wall and Floor Specimens

- B.1.2.7 The vertical and horizontal specimens tested in WF 182095 (the test was a combined wall and floor test) incorporated a seals that were 900mm in length
- B.1.2.8 AS1530.4-2005 requires that the linear gaps be of minimum 1000mm in length. The influence the length of specimen has on the performance is that it increases the shrinkage forces and tendency for a gap to form in the sealant material. Joints that are not backed by Rockwool will quickly lead to venting of the hot furnace gasses and a progressive insulation and integrity failure, as was observed with specimens E, B , I, and J.
- B.1.2.9 It is proposed a conservative approach be applied for these unbacked specimens and the fire resistance be reduced by 13 minutes to accommodate for the 10% increase in length of the seal and the associated increase in integrity risk.
- B.1.2.10 It is considered reasonable that a margin of 13 minutes be applied to the specimen B that is required to provide 180 minutes insulation. Further confidence in the safety of this proposition is provided by the larger margins of at least 28 minutes for seals E, J, and I as shown in Table B1.
- B.1.2.11 Based on the above discussion and in absence of any further insulation or integrity risk it is considered that the proposed insulation performances in Table B1 would likely be achieved if the specimen tested in WF 182095 had been tested in accordance with AS1530.4-2005.