

HardieGlaze Lining

Installation Manual

July 2021 New Zealand



We value your feedback!

To continue with the development of our products and systems, we value your input. Please send any suggestions, including your name, contact details, and relevant sketches to:

Ask James Hardie™
literaturefeedback@jameshardie.co.nz

Make sure your information is up to date

When specifying or installing James Hardie products, ensure that you have the current manual. Additional installation information, warranties and warnings are available at www.jameshardie.co.nz or **Ask James Hardie™** on 0800 808 868.

Contents

1	Product Overview	4	6	Installation	22
1.1	Product Information	4	6.1	Framing	24
1.2	Components and Accessories	6	6.2	Tolerances	24
1.3	Manufacturing and Classification	11	6.3	Sheet Fixing Requirements	24
2	Application and Scope	14	6.4	Fixing for Specific Applications	25
2.1	Application	14	6.5	Adhesive Fixing Only	25
2.2	Scope	14	6.6	Adhesive/fastfix fixing	31
2.3	Limitations	14	6.7	Fastfix Fixing Only	32
2.4	Details	14	6.8	Raised-Head Screw Fixing Method	33
3	Compliance	14	6.9	Sheet Set-out and Shower Rose Location	33
3.1	NZBC Compliance	14	6.10	Fixing to Fibre Cement or Plasterboard Substrate	33
4	Design	15	7	Joints	34
4.1	Responsibility	15	7.1	Dry Area Wall Joints – HardieGlaze Lining	34
4.2	Structure	15	7.1.1	Joints, Corners and Cap	34
4.2.1	Timber Framing	15	7.1.2	Wall to Ceiling joint	34
4.2.1	Steel Framing	15	7.2	Silicone Joints	38
4.2.1	Batten Requirements	15	7.2.2	Wall to Ceiling joint	39
4.3.2	Durability	16	7.3	Wet Area Wall Joints – HardieGlaze Lining	40
4.3	Food Preparation and Prevention of Contamination	17	7.3.1	Joints, Corners and Cap	40
4.4	Structural Bracing	17	7.3.2	Wet area wall-to-floor joints	43
4.6	Group Number Classification	17	8	Special Applications	48
5	Safe Working Practices	18	8.1	Indoor Swimming Pool Applications	48
5.1	Storage and delivery	20	8.2	Splashback	48
5.2	Tips for safe and easy handling of HardieGlaze™ Lining	21	8.3	Wet Area Penetration	49
			8.4	Sealants	49
			9	Care and Maintenance	50
			9.1	General	50
			9.2	Cleaning procedures	50
			Product Warranty	51	

1 Product Overview



1.1 Product Information

HardieGlaze™ Lining is an internal wall lining by James Hardie.

HardieGlaze Lining is a pre-finished wall and ceiling lining made from James Hardie fibre cement and is suitable for use in wet or dry areas that require a sealed, impervious surface. It is an easy clean, antimicrobial protection, high gloss UV cured coated finish that's suitable for residential or commercial applications with no backing substrate required. HardieGlaze Lining is resistant to fire and damage from moisture, rotting and cracking, when installed and maintained in accordance to the information published in this manual.

For advice on HardieGlaze Lining, Ask James Hardie™ on 0800 808 868.

Table 1

HardieGlaze Lining information					
Product	Description	Quantity / size			
	<p>HardieGlaze Lining 4.5mm High-gloss UV cured finish. Is back sealed. Available in white. Square sheet edge Mass at equilibrium moisture content is 7kg/m²</p>	Thickness: 4.5mm			
		Length (mm)	Width (mm)	Colour	Code
		2400	1200	White	400221
		2400	900	White	400225
	<p>HardieGlaze Lining Tile Square-tile pattern embossed into a hard-wearing, high gloss UV cured coating. Is back sealed. Available in white. Mass at equilibrium moisture content is 9.5kg/m²</p>	Thickness: 6mm			
		Length (mm)	Width (mm)	Colour	Code
		2400	1200	White	400240
	<p>HardieGlaze Lining 6mm High-gloss UV cured finish, back sealed, designed for residential, commercial and industrial wet and dry areas, ideal for food processing areas where strict hygiene conditions apply. Available in white. Radius sheet edge Mass at equilibrium moisture content is 9.5kg/m²</p>	Thickness: 6mm			
		Length (mm)	Width (mm)	Colour	Code
		2700	1200	White	400210
		2400	1200	White	400211

Note:

HardieGlaze Lining must have primer applied where indicated in this manual.

All dimensions and masses provided are approximate only and subject to manufacturing tolerances.

HardieGlaze Lining sheets vary in moisture content with the seasons.

Where possible sheet edges with greater coverage (typically one end) are best orientated so that they are the lowest edge.

1.2 Components and Accessories

Table 2





uPVC jointers and mouldings for HardieGlaze Lining 4.5mm only				
Accessories	Description	Length (mm)	Material/appearance	Code
	Sheet Joints	2400	uPVC Gloss White	300690
	Cap Mould	2400	uPVC Gloss White	300678
	External Corner Mould	2400	uPVC Gloss White	300682
	Internal Corner Mould	2400	uPVC Gloss White	300686
	Bath Mould 4.5mm	2500	uPVC Gloss White	300674

Table 3





Aluminium jointers and mouldings for HardieGlaze Lining 4.5mm only				
Accessories	Description	Length (mm)	Material/appearance	Code
	Sheet Joints	2700	Aluminium Naturally Anodised	304507
	Cap Mould	2700	Aluminium Naturally Anodised	304501
	External Corner Mould	2700	Aluminium Naturally Anodised	304503
	Internal Corner Mould	2700	Aluminium Naturally Anodised	304505

Table 4







uPVC jointers and mouldings for HardieGlaze Lining 6mm only				
Accessories	Description	Length (mm)	Material/appearance	Code
	Sheet jointer	2700	uPVC Gloss White	300713
	Cap mould	2700	uPVC Gloss White	300695
	Internal corner mould	2700	uPVC Gloss White	300707
	External corner mould	2700	uPVC Gloss White	300701
	Bath mould 6mm	2500	uPVC Gloss White	300691
	Flexible-edge 2-piece internal uPVC corner mould	2700	uPVC Gloss White	300946

Table 5









Aluminium jointers and mouldings for HardieGlaze Lining 6mm only				
Accessories	Description	Length (mm)	Material/appearance	Code
	Sheet Jointer	2700	Aluminium Naturally Anodised	304506
	Cap Mould	2700	Aluminium Naturally Anodised	304500
	Internal Corner	2700	Aluminium Naturally Anodised	304504
	External Corner	2700	Aluminium Naturally Anodised	304502
	Sheet jointer	2700	Aluminium White	305750
	Cap mould	2700	Aluminium White	305751
	Internal Corner	2700	Aluminium White	305749
	External Corner	2700	Aluminium White	305748
	Negative jointer	2700	Aluminium naturally anodised	305752

Table 6











HardieGlaze Lining accessories for the full 4.5mm and 6mm range				
Accessories	Description	Length (mm)	Material/appearance	Code
	Fastfix fasteners	40 100 per pack	Nylon Gloss White	300632
	Scotia mould	2400	uPVC Gloss white 2-piece Base and Cap	300916

Table 7

HardieGlaze Lining accessories				
Accessories	Description	Size (mm)	Material/appearance	Code
	HardieBlade Saw Blade	184mm		300660
	James Hardie Two Sided Adhesive Tape To go on timber framing as optional fixing used in conjunction with adhesive fixing	12mm x 33m	Red Tape	305433
	HardieKnife			305926

Table 8

Accessories not supplied by James Hardie			
The following products are for use in conjunction with HardieGlaze Lining. James Hardie does not supply these products. Please contact component manufacturer for information on their warranties and further information on their products.			
Accessories	Description	Unit	Quantity
	Sealer Dulux Acraprime 501/1, Dulux 1 Step or similar	Tin	
	Gator Bond Breaker Tape Blue or 3M 500 tape To go behind sealant joint	Roll	55m
	Sika SikaFlex 11FC, Bostik Seal n Flex-1, No more nails, Fullers Max Bond or similar	Cartridge	
	Masking Tape 3M Scotch™ Blue™ #2090 – 18E 70006576972 or Sellotape 5855 Long Life	Roll	55m
	Sealant Sika Sikasil NG (translucent) or Sika Sikasil RTV (+ SikaPrimer-3N), Sika Sikasil Wet Areas or Fullers 770 Sanitary	Cartridge	
	C-25 Brad Nail	Box	
	Fibre Shear Cutter from building/tools supplier		
	Pan head/hex head screw for exposed fixing		
	6mm drill bit to be used for fixing Fastfix Fasteners		

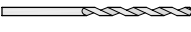
1.3 Manufacturing and Classification

James Hardie New Zealand Limited is an ISO 9001 Telarc certified manufacturer.

The base sheets are a light grey colour. All sheets have the face side fully sanded to give a smooth finish. HardieGlaze Lining is manufactured using a basic composition of Portland cement, ground sand, cellulose fibre and water.

HardieGlaze Lining has the name 6.0 Base Sheet or 4.5 Base Sheet printed across the back of all sheets at regular intervals. Additional identification is the name written on the sticker applied to back of lining.

HardieGlaze Lining 4.5mm has a square edge finish to its sheet edges and HardieGlaze Lining 6mm has a radius edge finish to its sheet edges.

HardieGlaze Lining are manufactured to the Australian/New Zealand Standard AS/NZS 2908.2 'Cellulose-Cement Products' (ISO 8336 'Fibre-Cement Flat Sheet'). HardieGlaze Lining is classified Type B, Category 3 in accordance with the AS/NZS 2908.2 "Cellulose-Cement Products".

For Safety Data Sheets (SDS) visit www.jameshardie.co.nz and view them in the technical literature section or Ask James Hardie on **0800 808 868**.

Figure 1: HardieGlaze Tile Lining pattern

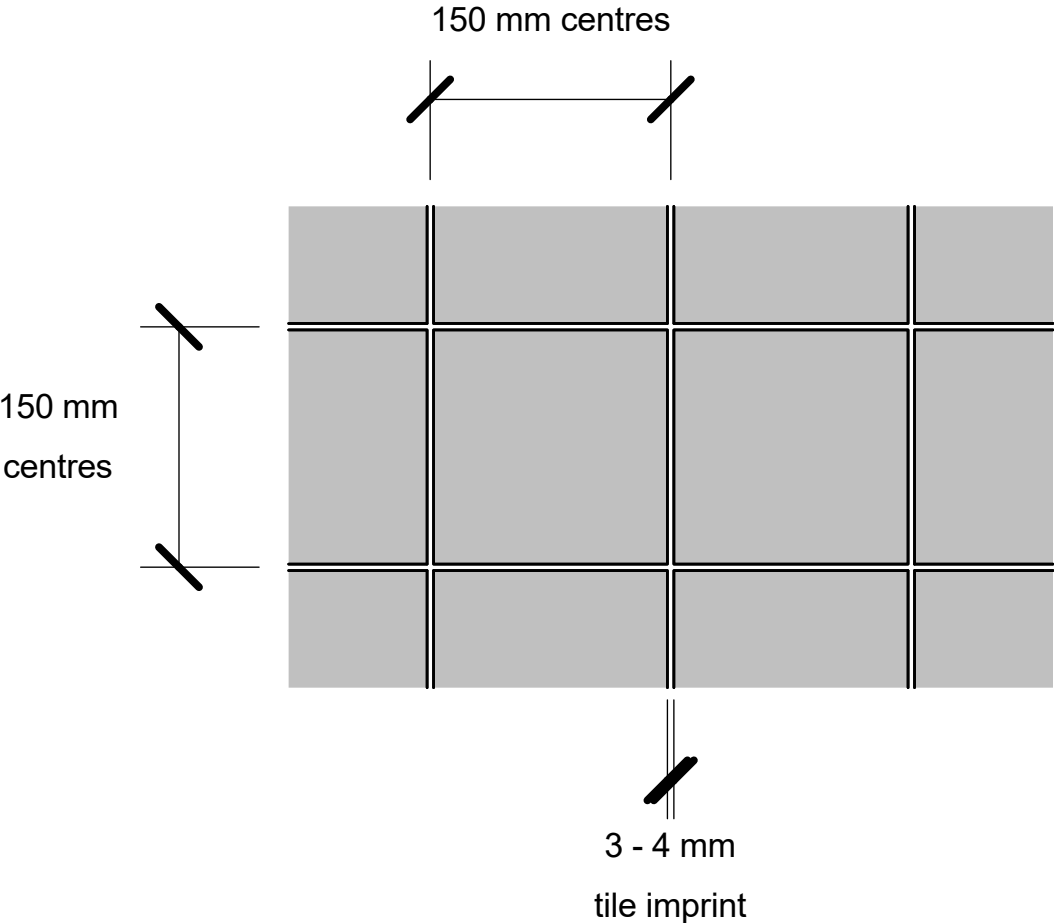
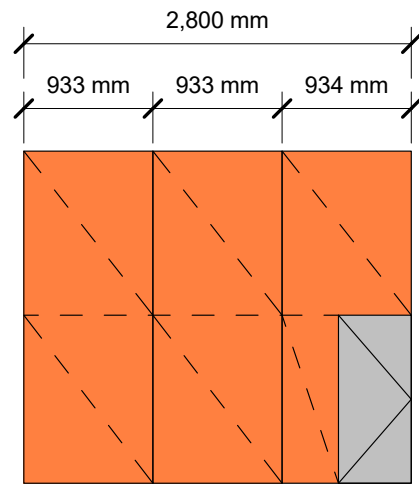
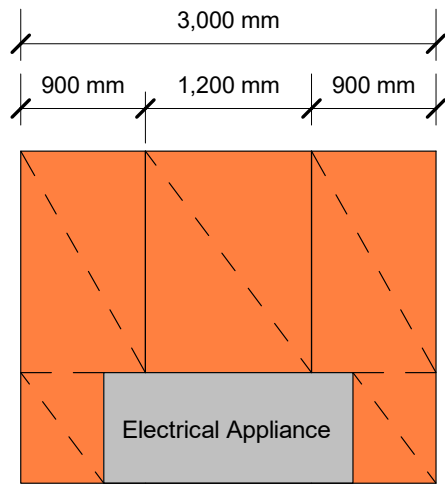
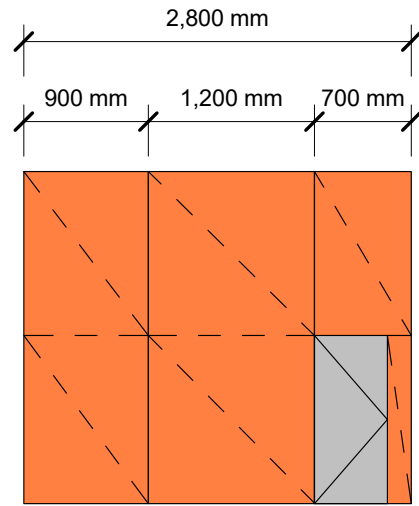
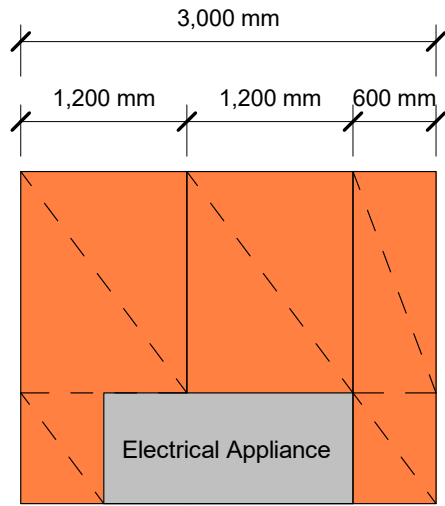

Figure 2: HardieGlaze Lining layout



Notes:

Where possible sheet edges with greater coating coverage (typically one end) are best orientated so that they are the lowest edge.

2 Application and Scope

2.1 Application

HardieGlaze Lining can be fixed directly to timber or steel frames used for internal lining application.

2.2 Scope

This specification covers the installation of HardieGlaze Lining for internal lining or ceiling fixed to framing that complies with the requirements of the NZBC.

2.3 Limitations

- HardieGlaze Lining must not be used as an external cladding
- HardieGlaze Lining must not be used in curved wall applications

2.4 Details

Various typical HardieGlaze Lining details are provided within this document. The construction details are available on our website. These details are available in dwg, dxf, jpg and pdf file format and can be downloaded at www.jameshardie.co.nz.

All dimensions shown are in millimetres unless noted otherwise.

3 Compliance

3.1 NZBC Compliance

HardieGlaze Linings comply with section 3.1.2 of E3/AS1. Information contained in this document regarding the installation of HardieGlaze Linings are aligned with E3/AS1 of the NZBC.

HardieGlaze Linings have an impervious coating and comply with E3/AS1 requirements.

4 Design

4.1 Responsibility

This document is intended for use by architects, designers, specifiers or builders who are involved in specifying HardieGlaze Lining.

All New Zealand Standards referenced in this manual are current edition and must be complied with.

Specifier

If you are a specifier or other responsible party for a project ensure that the information in this document is appropriate for the application you are planning and that you undertake specific design and detailing for areas which fall outside the scope of these specifications.

For advice on designs outside the scope of this specification, Ask James Hardie on 0800 808 868.

Installer

If you are an installer ensure that you follow the design, moisture management principles, associated figures and material selection provided by the designer and this James Hardie Installation Manual.

All the details provided in this document must be read in conjunction with the project specification.

James Hardie conducts stringent quality checks to ensure that any product manufactured falls within our quality spectrum. It is the responsibility of the builder to ensure that the product meets aesthetic requirements before installation. James Hardie will not be responsible for rectifying obvious aesthetic surface variations following installation.

4.2 Structure

4.2.1 Timber Framing

Timber framing must be in accordance with the NZS 3604 (Timber-framed buildings) or as per specific engineering design (SED) to the NZS 3603 and the AS/NZS 1170. Where specific engineering design is undertaken, the framing stiffness must be equivalent to or more than the framing provisions of the NZS 3604.

Refer to the NZS 3602 regarding timber treatment requirements and allowable moisture contents of timber.

4.2.1 Steel Framing

HardieGlaze Lining can also be installed to steel frame. The steel framing must be in accordance with NASH Standard Part 2: 2019 'Light Steel Framed Buildings' and the stud/nog spacing as specified timber frame.

The framing must be firm and secured together and must not rely on HardieGlaze Lining for stability. The minimum flange width of 38mm is required to adequately adhere the sheets.

4.2.1 Batten Requirements

Timber/steel battens are required where the linings sheets are fixed over:

- polystyrene or similar substrates
- concrete, masonry block or brick walls

Allow concrete or block walls to dry out before battening and ensure that all exterior wall faces are adequately sealed. Take care to ensure the battens are packed to be in plumb line and have a flat even surface to adhere the lining sheets. Refer to batten layout figure.

Figure 3: HardieGlaze Lining over masonry wall

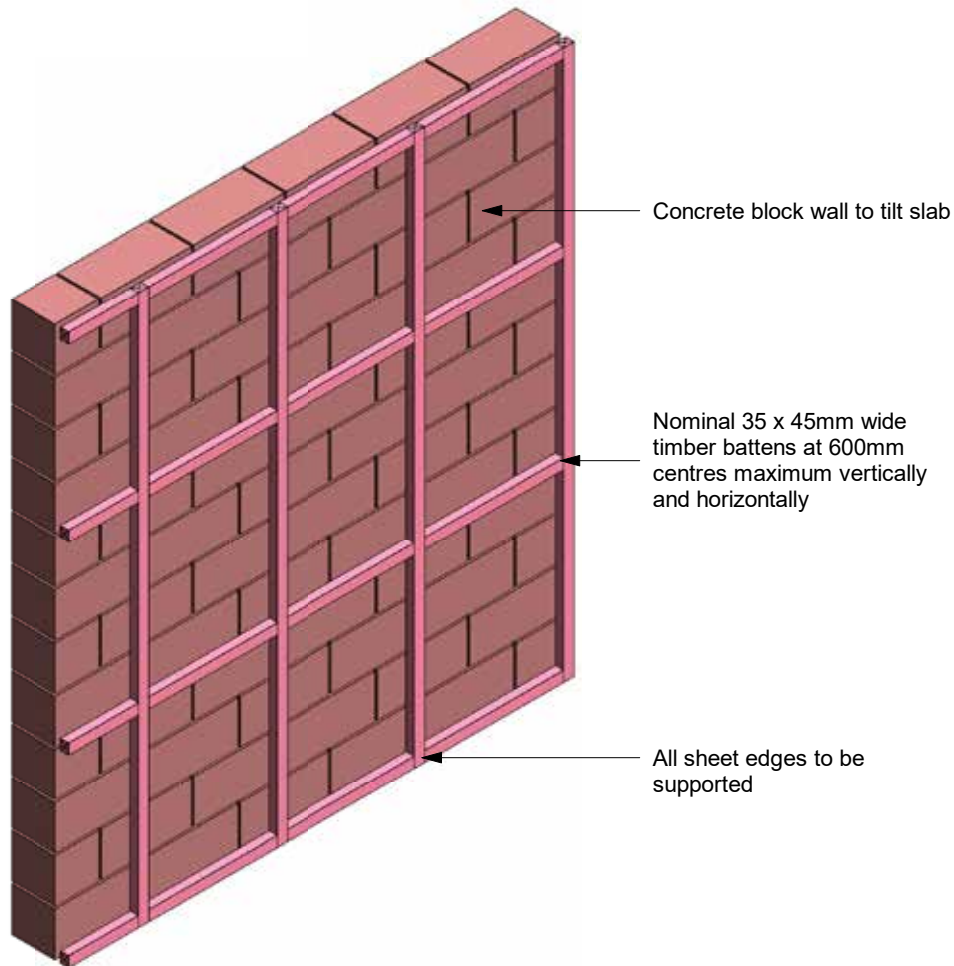

4.3.2 Durability

Although HardieGlaze Lining is resistant to moisture, the product specification must be designed, installed and maintained to resist the penetration of moisture. HardieGlaze Lining installed as per this installation manual complies with the 15 year durability requirement of the NZBC.

HardieGlaze Lining has demonstrated resistance to permanent moisture induced deterioration (rotting) by passing the following tests in accordance with AS/NZS 2908.2:

The HardieGlaze Lining are:

- Heat rain (Clause 6.5)
- Water permeability (Clause 8.2.2)
- Warm water (Clause 8.2.4)
- Soak dry (Clause 8.2.5)

4.3 Food Preparation and Prevention of Contamination

The surface of HardieGlaze Lining complies with the requirements of Clause G3 of the NZBC, when fixed to the hygiene area details provided in this installation manual.

4.4 Structural Bracing

Because HardieGlaze Lining sheets are adhesive fixed, they are not suitable for structural sheet bracing. When structural sheet bracing is required, mechanically fix a sheet of Villaboard™ Lining to give the bracing rating required, then adhesive fix the HardieGlaze Lining onto the face of the Villaboard Lining. Refer to the James Hardie Bracing Design Manual for further bracing information.

4.6 Group Number Classification

Internal wall linings are required to be tested to establish their 'Group Numbers' in accordance with ISO 5660 or ISO 9705 as per 'Protection from Fire' Clause C of the NZBC. HardieGlaze Lining have been tested and have '**Group Number 1-S**' classification. This is the best performance that can be expected of a prefinished wall lining.

Because the sheets are adhesive fixed they are not suitable for fire rated wall applications. Villaboard Lining must be used for fire rated system with HardieGlaze Lining adhered to it.

Refer to the James Hardie Fire and Acoustic Design Manual for further information.

5 Safe Working Practices

WARNING - DO NOT BREATHE DUST AND CUT ONLY IN WELL VENTILATED AREA

James Hardie products contain sand, a source of respirable crystalline silica

May cause cancer if dust from product is inhaled. Causes damage to lungs and respiratory system through prolonged or repeated inhalation of dust from product.

Intact fibre cement products are not expected to result in any adverse toxic effects. The hazard associated with fibre cement arises from the respirable crystalline silica present in dust generated by activities such as cutting, rebating, drilling, routing, sawing, crushing, or otherwise abrading fibre cement, and when cleaning up, disposing of or moving dust.

When doing any of these activities in a manner that generates dust, follow James Hardie instructions and best practices to reduce or limit the release of dust.

If using a dust mask or respirator, use an AS/NZS 1716 P1 filter and refer to Australian/New Zealand Standard 1715:2009 Selection, Use and Maintenance of Respiratory Protective Equipment for more extensive guidance and more options for selecting respirators for workplaces. For further information, refer to our installation instructions and Safety Data Sheets available at www.jameshardie.co.nz.

FAILURE TO ADHERE TO OUR WARNINGS, SAFETY DATA SHEETS, AND INSTALLATION INSTRUCTIONS MAY LEAD TO SERIOUS PERSONAL INJURY OR DEATH.

Crystalline Silica is

- Commonly known as sand or quartz
- Found in many building products e.g. concrete, bricks, grout, wallboard, ceramic tiles, and all fibre cement materials

Why is Crystalline Silica a health hazard?

- Silica can be breathed deep into the lungs when present in the air as a very fine (respirable) dust
- Exposure to silica dust without taking the appropriate safety measures to minimise the amount being breathed in, can lead to a potentially fatal lung disease – silicosis – and has also been linked with other diseases including cancer. Some studies suggest that smoking may increase these risks
- The most hazardous dust is the dust you cannot see!

When is Crystalline Silica a health hazard?

- It's dangerous to health if safety protocols to control dust are not followed when cutting, drilling or rebating a product containing crystalline silica and when cleaning up
- Products containing silica are harmless if intact (e.g. an un-cut sheet of wall board)

Avoid breathing in crystalline silica dust

Safe working practices

- ✗ NEVER use a power saw indoors or in a poorly ventilated area
- ✗ NEVER dry sweep
- ✓ ALWAYS use M Class or higher vacuum or damp down dust before sweeping up
- ✗ NEVER use grinders
- ✓ ALWAYS use a dust reducing circular saw equipped with a sawblade specifically designed to minimise dust creation when cutting fibre cement – preferably a sawblade that carries the HardieBlade™ logo or one with at least equivalent performance – connected to an M Class or higher vacuum
- ✓ Before cutting warn others in the area to avoid dust
- ✓ ALWAYS follow tool manufacturers' safety recommendations
- ✓ ALWAYS expose only the minimum required depth of blade for the thickness of fibre cement to be cut
- ✓ ALWAYS wear a properly-fitted, approved dust mask or respirator P1 or higher in accordance with applicable government regulations and manufacturer instructions
- ✓ Consider rotating personnel across cutting tasks to further limit respirable silica exposures.

Use one of the following methods for cutting HardieGlaze Lining:

Best

- HardieKnife™
- Fibreshear

Better

Dust reducing circular saw equipped with HardieBlade™ Saw Blade and connected to a M Class or higher vacuum.

When cutting outdoors

- ✓ Make sure you work in a well-ventilated area
- ✓ Position cutting station so wind will blow dust away from yourself and others in the working area
- ✓ Cut products with either a HardieKnife or fibre cement shears or, use a HardieBlade Saw Blade (or equivalent) and a dust reducing circular saw connected to a M Class or higher vacuum
- ✓ When sawing, sanding, rebating, drilling or machining fibre cement products, always:
 - Wear your P1 or P2 mask (correctly fitted in accordance with manufacturers' instructions), ask others to do the same.
 - Keep persons on site at least 2 metres and as far as practicable away from the cutting station while the saw is in operation
 - If you are not clean shaven, then use a powered air respirator with a loose fitting head top
 - Wear safety glasses
 - Wear hearing protection
 - When others are close by, ask them to do the same
- ✓ Make sure you clean up BUT never dry sweep. Always hose down with water/wet wipe or use an M Class or higher vacuum

When cutting indoors

- ✗ Never cut using a circular saw indoors
- ✓ Position cutting station in a well-ventilated area
- ✓ Cut ONLY using a HardieKnife or fibreshears.
- ✓ Make sure you clean up BUT never dry sweep. Always hose down with water/wet wipe or use an M Class or higher vacuum

Working Instructions

HardieBlade™ Saw Blade

The HardieBlade Saw Blade used with a dust-reducing saw is ideal for fast, clean cutting of James Hardie fibre cement products. A dust-reducing saw uses a dust collector connected to a M Class or higher vacuum. When sawing, clamp a straight edge to the sheet as a guide and run the saw base plate along the straight edge when making the cut.

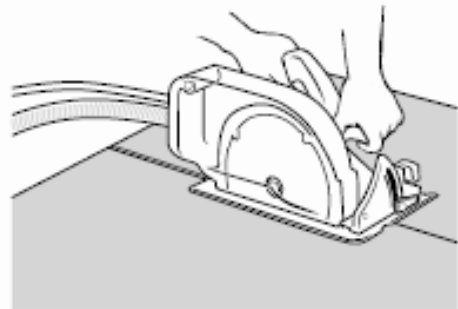

Hole-Forming

For smooth clean cut circular holes:

- Mark the centre of the hole on the sheet
- Pre-drill a 'pilot' hole
- Using the pilot hole as a guide, cut the hole to the appropriate diameter with a hole saw fitted to a heavy duty electric drill



For irregular holes:

- Small rectangular or circular holes can be cut by drilling a series of small holes around the perimeter of the hole then tapping out the waste piece from the sheet face
- Tap carefully to avoid damage to sheets, ensuring that the sheet edges are properly supported

5.1 Storage and delivery

Keeping products and people safe

Off loading

- ✓ James Hardie products should be off-loaded carefully by hand or by forklift
- ✓ James Hardie products should not be rolled or dumped off a truck during the delivery to the jobsite

Storage

James Hardie products should be stored:

- ✓ In their original packaging
- ✓ Under cover where possible or otherwise protected with a waterproof covering to keep products dry
- ✓ Off the ground – either on a pallet or adequately supported on timber or other spacers
- ✓ Flat so as to minimise bending

James Hardie products must not be stored:

- ✘ Directly on the ground
- ✘ In the open air exposed to the elements

James Hardie is not responsible for damage due to improper storage and handling.

5.2 Tips for safe and easy handling of HardieGlaze Lining

- ✓ Carry with two people
- ✓ Hold near each end and carry the sheet on its edge
- ✓ Do not flex the sheets as this may damage the coating
- ✓ Exercise care when handling sheet products to avoid damaging the edges/corners

6 Installation

Step 1: Before you start

- Read the information in this manual. Note that HardieGlaze Lining is NOT suitable for floors, benchtops, exterior cladding or exterior signage.
- Check that timber for framing is dry — the moisture content as per the NZS 3602.
- Check the sheet batch numbers to ensure the sheets are all from the same batch to be colour matched.
- Ensure the timber and sheet surface are free from any dirt or grime before installation.

Step 2: Assemble your tools

- Caulking gun
- Hand saw
- Hammer
- Electric drill and titanium bits
- Level
- Tape measure
- Saw horses
- Rasp
- Pencil
- HardieKnife™

Step 3: Check your materials

- HardieGlaze Lining sheets 900mm or 1200mm wide.
- Construction adhesive sealant refer Table 8.
- uPVC or aluminium sheet jointers and mouldings (refer Tables 2-5).
- Silicone sealant refer Table 8 (refer Figure 26) and recommended masking tape.
- Polyurethane/polyethylene bondbreaker tape.
- Timber cut to length for temporarily bracing sheets into place.
- Batch numbers are identical.
- Arrow directions on tile.

Step 4: Choose the installation method

- Ascertain the correct HardieGlaze Lining sheets to meet your specific requirements (refer to Table 1).
- Choose the appropriate fixing method (refer Table 9).
- Choose the appropriate edge sealing and jointing method.

Step 5: Prepare your walls

- Check framing for flatness and straightness. Plane back any timber high spots.
- Check that all framing is secure and well nailed.
- Punch all framing nails.
- Check that all plumbing and electrical fittings are fixed in the correct location.
- Accurately measure the distances between framing for sheet sizes. Measure at the top, bottom and centre of the frame as a check, and allow tolerances so the sheet will fit easily.

Step 6: Measure the sheets

- When cutting, accurately measure and mark out on the face of the sheet (use a soft builder's pencil). Allow 1 to 2mm clearance each side to fit into jointers.
- When using mouldings, accurately measure the mould to work out allowances for fitting into the moulding.
- Allow for sealant width when using silicone joints.

Step 7: Cut and form the sheets

- Accurately cut the sheets.
- Mark out positions of holes or penetrations in sheets.
- HardieGlaze Lining sheets with cut edges must be site prepared and primed before applying sealant (refer page 24).
- Lining sheets to baths or bottom of showers must have bottom edge and back 100mm sealed (refer to Figures 38 - 44).
- For best results in shower applications always use the factory finished edge for the bottom drip edge.

Step 8: adhesive, sealant and install the sheets

- Refer to Section 7 for jointing options. Always ensure the timber or sheet surface are free from any dirt or grime before installation.

For uPVC/aluminium jointing:

- Fix the jointer to the studs first.
- Place sealant in jointers if required (refer Figure 28 - 39).
- Fit the sheet into jointer and press onto the adhesive daubs applied over timber frame and pack the sheet off the floor or base with 6mm minimum packers. Hold the sheet in place until temporary bracing is applied.
- When using James Hardie two sided adhesive tapes in conjunction with adhesives, no temporary bracing is required.
- When fixing in a three sided shower, fix the first sheet onto the adhesive with the jointers on both sides of the sheet in place.
- Fix the second and subsequent sheets in place with the jointer to one edge as required.
- Ensure that all sheets are truly aligned and fit tightly into jointers, then temporarily brace into place.

For silicone jointing:

- Fix bond breaker tape to the framing behind the joints before fixing sheets (refer Figure 26).
- Press the sheets onto adhesive daubs/bead applied over timber frame and pack the sheet off the floor or base with 6mm minimum packers. Hold the sheet in place until temporary bracing is applied (refer Figure 6).
- Space the correct gap between sheet edges.
- Apply sealant between joints.
- Do not touch silicone sealant with bare fingers as this can encourage mould growth.

Note: A spacer gives the correct gap for HardieGlaze Lining Tile and HardieGlaze Lining 6mm (refer to Figure 26).

Sealing Penetrations:

- Apply sealant around taps and fixture penetrations after fixing the sheets into place.

Step 9: Finishing touches

Only use specific masking tapes on surface, refer Table 8. Incorrect tapes can cause coating removal.

- Clean up all sheets and jointers with kerosene on a clean cloth to remove all pencil marks, adhesive or excess sealant.
- Remember to maintain the sheets and clean on a regular basis (refer Section 9).

6.1 Framing

The following framing must be provided for the installation of HardieGlaze Lining:

- Framing be minimum 45mm wide
- Studs provided at 600mm centres maximum
- Continuous top and bottom plates
- Nogs at 1200mm maximum centres

6.2 Tolerances

In order to achieve an acceptable wall finish, it is imperative that framing is straight and true. Framing tolerances must comply with the requirements of the NZS 3604 and the manufacturer's specifications. All framing must be made flush. The visual aspects of the finished lining can between two different sites or the builders installing the product. It is recommended that you also refer to a building guidance document published by MBIE to understand an acceptable level of tolerances allowed in building materials and workmanship. **www.building.govt.nz, Guide to tolerances, materials and workmanship in new residential construction 2015**

HardieGlaze Lining are manufactured to a size tolerance of 3mm when measured diagonally.

6.3 Sheet Fixing Requirements

All fixing for walls and ceilings must comply with this specification.

At all adhesive-fixed sheet joints, the centre line of the joint must coincide with the centre line of the stud, nog or plate. This is to ensure sufficient adherence of adjoining sheets to the frame along the sheet edges.

Best practice notes: In wet areas you must use:

1. Use a factory sealed edge at the bottom.
2. If there is any variation in quality of the factory sheet edges, put the best sheet edge to the bottom.

Fix the sheet from the centre working towards the outside, to avoid drumminess.

Fix 4.5mm and 6mm HardieGlaze Lining to the timber or steel frame using solvent-based or foam polyurethane wallboard adhesive (to the centres shown in the relevant diagrams), to the perimeter of all sheets, intermediate studs, plates and nogs. For further adhesive instructions refer to adhesive fixing clause in this manual.

Sheets must be fixed 6mm clear of the floor for general wall applications. Care must be taken to ensure that this gap does not become filled with residue during the construction process.

Fix uPVC or aluminium mouldings with nails at 300mm maximum centres.

Aluminium mouldings may also be fixed to frame with C-25 brad nails at 300mm maximum centres.

For sheets with a shower base refer to Figures 39 - 41.

Cut-edge sealing

Before any sealants are applied to site-cut HardieGlaze Lining sheet edges, the raw edge must be site primed. Use Dulux 1 Step, Dulux Acraprime 501/1 or similar. Be careful not to miss any areas. All site-cut sheet edges for silicone joints must be site sealed. All HardieGlaze Lining 6mm sheet edges must be sealed for all installations. For best results in shower applications always use the factory-finished edge for the bottom drip edge.

6.4 Fixing for Specific Applications

Table 9

Specific application	Lining	Fixing method options for walls and ceilings
Wet or dry areas that require a sealed impervious surface	HardieGlaze Lining 4.5mm HardieGlaze Lining Tile HardieGlaze Lining 6mm	Use one of the following: <ul style="list-style-type: none"> • Adhesive (for walls, refer to Figure 4 and 5; for ceilings, refer Figure 7). • Adhesive/Fastfix (refer Figures 8 and 9).
Dry areas	HardieGlaze Lining 4.5mm HardieGlaze Lining Tile HardieGlaze Lining 6mm	Use one of the following: <ul style="list-style-type: none"> • Adhesive (for walls, refer to Figure 4 and 5; for ceilings, refer Figure 7). • Adhesive/Fastfix (refer Figures 8 and 9). • Adhesive/Screw (refer to Figure 4 and 10).
Wet or dry areas that require moderate protection from dirt and bacteria	HardieGlaze Lining 4.5mm HardieGlaze Lining Tile HardieGlaze Lining 6mm	Use one of the following: <ul style="list-style-type: none"> • Adhesive (for walls, refer to Figure 4 and 5; for ceilings, refer Figure 7).
Strict hygiene (MAF compliance)	HardieGlaze Lining 6mm	Walls: <ul style="list-style-type: none"> • Adhesive (refer to Figure 4 and 5). Ceilings: <ul style="list-style-type: none"> • Adhesive (refer Figure 7)

6.5 Adhesive Fixing Only

Adhesive fixing is used to avoid fixing penetrations in the sheet face. Fix HardieGlaze Lining to the framing with a good-quality polyurethane wallboard adhesive.

For adhesive fixing the HardieGlaze Lining sheet can either be fixed in conjunction with James Hardie two sided adhesive tape or the sheet can be temporarily braced for approximately 24 hours to allow the adhesives to cure and gain full adhesion.

When using two sided adhesive tape, apply long strips of tape on the framing with 15mm daubs of adhesive beside which are applied at 200mm centres to the entire framing. Refer to Section 9 for figure.

Do not apply double sided tape on the stud where a jointer is fixed as the tape will not allow the HardieGlaze Lining sheet to slide into the jointer.

When using the temporary bracing method always ensure that the edges and the sheet surface is braced adequately and protect the sheet surface against scratching. The bracing member should be aligned with the framing behind HardieGlaze Lining. Support and temporarily brace the sheets during adhesive setting, in accordance with the adhesive manufacturer's instructions.

Wallboard adhesives should be suitable for HardieGlaze Lining applications in accordance with this manual. Recommended adhesives include: Sika Nailbond Fast, Sika NailBond PB, Fullers Maxbond, Bostik Tuf As Nails, Bostik 'Seal-N-Flex-1', Selleys Liquid Nails, Sikaflex-11FC or similar. Refer to adhesive manufacturers' recommendations to ascertain suitability for the intended use.

- Clean the frame surface before applying the adhesive. Also clean the back surface of HardieGlaze Lining before fixing to remove any loose material/dust.
- Never force sheets into position.
- Place daubs of wallboard adhesive on studs/intermediate studs or battens and nogs at 200mm centres
- Refer to adhesive manufacturer's recommendations to ascertain if adhesive installation should be daubs or continuous bead and the appropriate size of either.

- Fit aluminium sheet jointers to both sides of the HardieGlaze Lining sheet or allow spacings between the sheets for silicone joints.
- In wet areas, you must use silicone sealant in the jointers and mouldings.
- The aluminium sheet jointers are brad nail fixed into position at 300mm max centres.
- The edge of the sheets must be spaced appropriately when silicone jointing method is used.
- Once the sheets are adhesive fixed and finally in place, either the temporary bracing is required or adhesive tape is used to hold the sheet. Always protect the sheet surface against scratching.

Notes:

1. Refer to adhesive manufacturer's recommendations for use.
2. The contact method of adhesive bonding can also be used by experienced builders.
3. Ensure the room is well ventilated when working with solvents.

Figure 4: HardieGlaze Lining Adhesive fixing detail

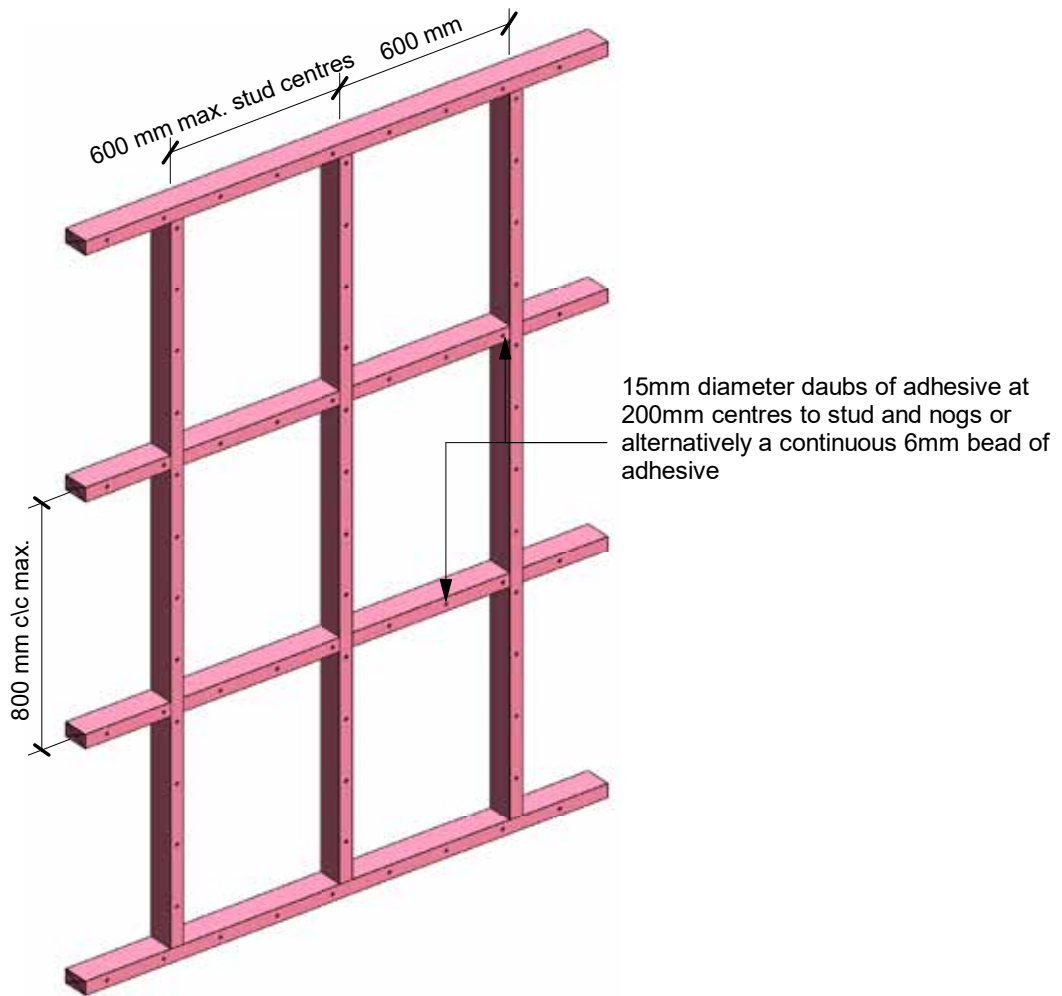

Figure 5: HardieGlaze Lining fixing to walls tape and adhesive and adhesive method

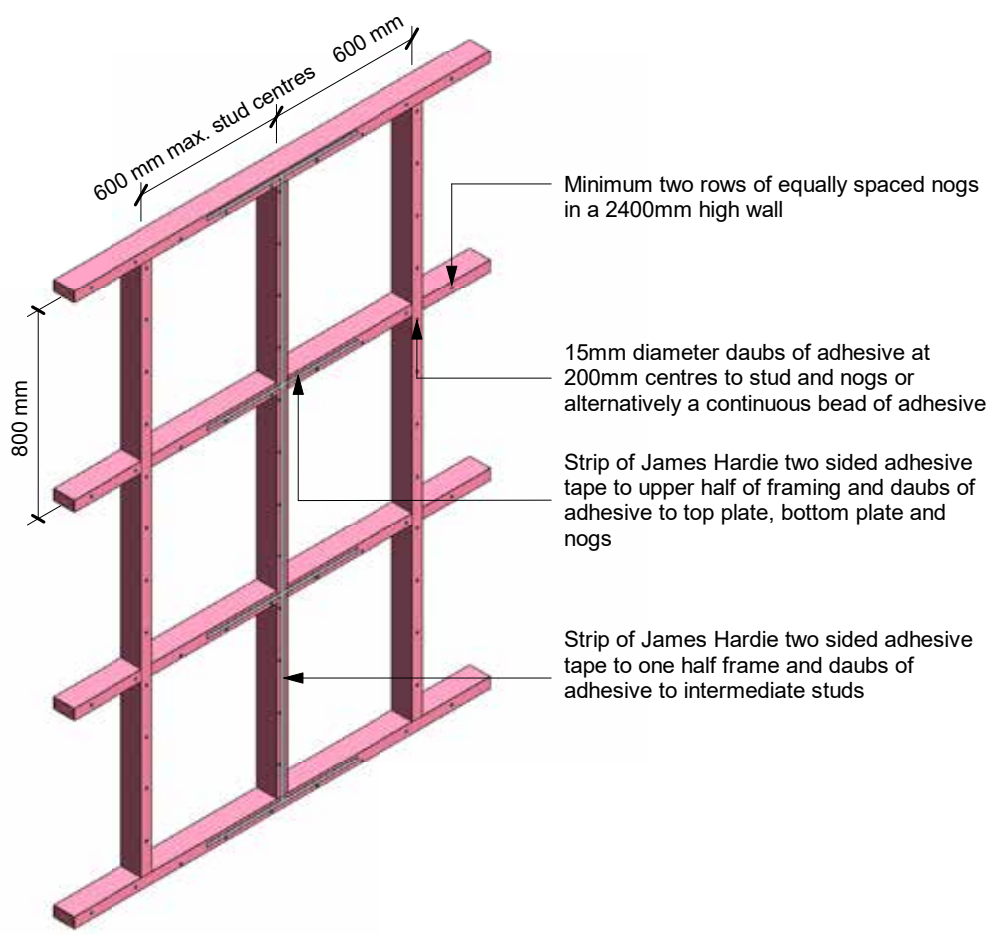
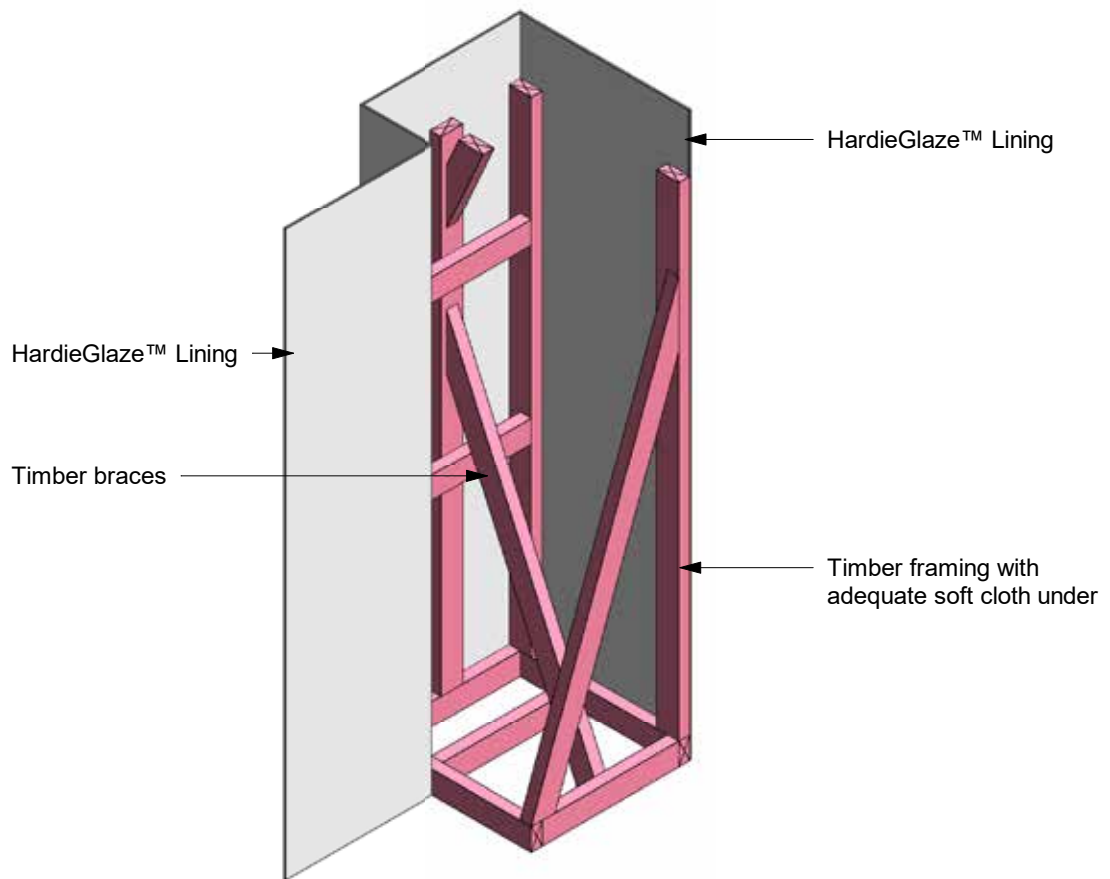
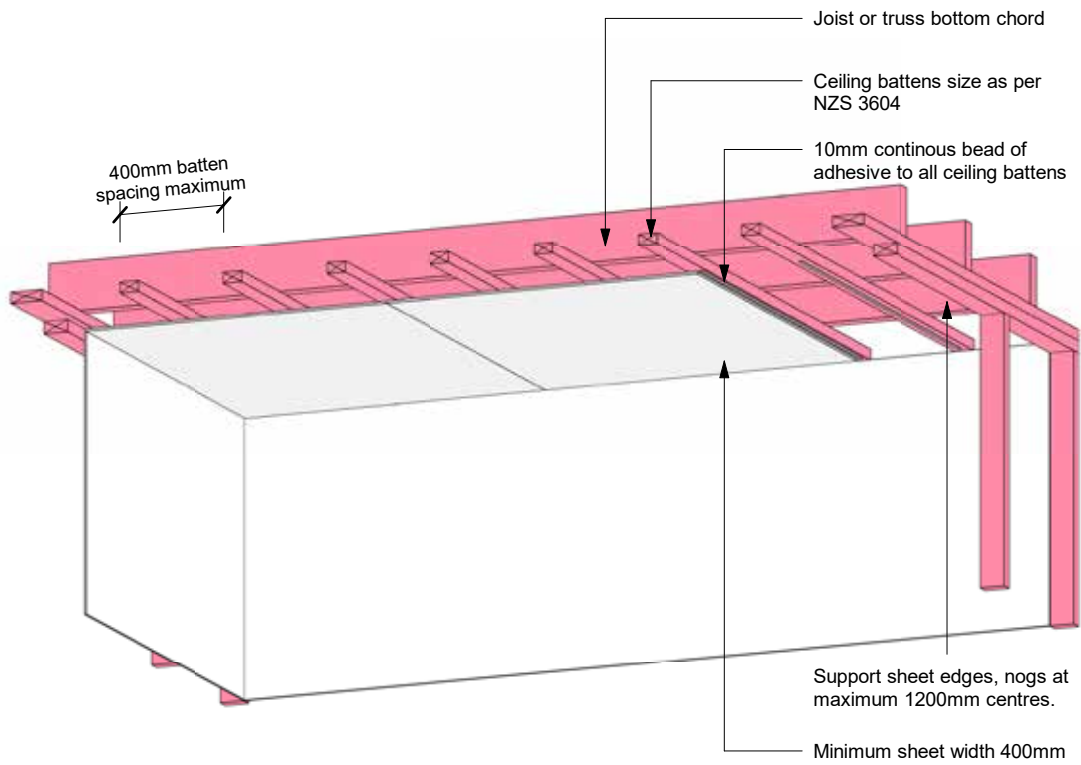

Figure 6: Temporary HardieGlaze Lining brace detail



Notes:
Ensure edges are well braced and timber braces are aligned over solid framing behind

Figure 7: HardieGlaze Lining fixing to ceilings - adhesive method



Notes:
This method requires the sheets to be fully braced temporarily while the adhesive cures.
Bracing member should be aligned with the framing behind prefinished Lining.

6.6 Adhesive/Fastfix Fixing

This method uses adhesive as the main sheet fixing, combined with a minimum number of Fastfix fasteners to hold the sheet in place while the adhesive sets. This method is particularly suitable for walls and ceilings where temporary bracing may be difficult (refer Figure 8).

Note: Temporary bracing must be applied to the sheet areas between the Fastfix fasteners, to avoid sag.

Figure 8: HardieGlaze Lining fixing to walls - fastfix and adhesive

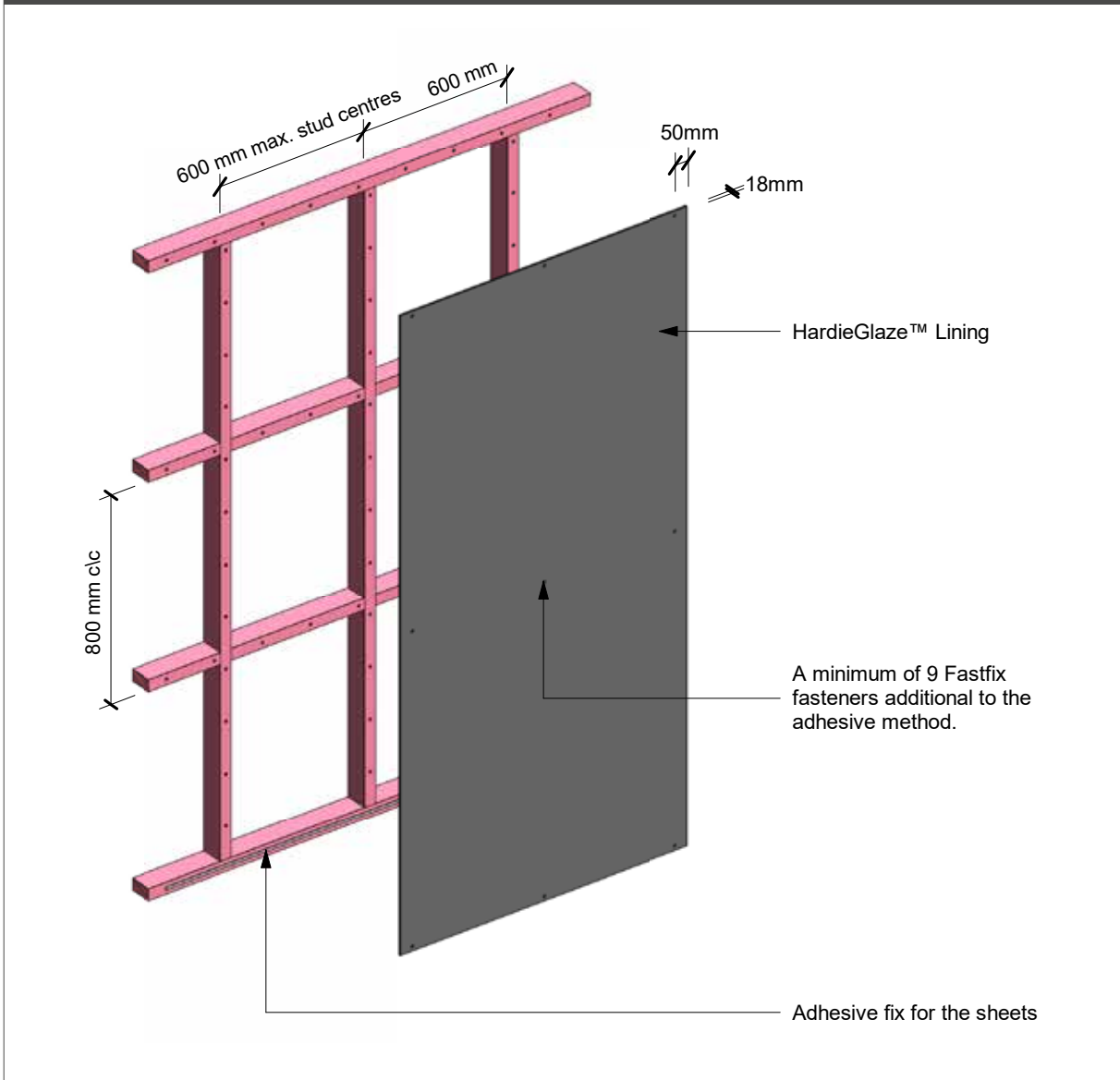

6.7 Fastfix Fixing Only

Sheets can be fixed with Fastfix fixing at 300mm centres to all framing for walls and ceilings (refer Figure 9). This method is a fully visible mechanical fixing method when adhesive fixing is not suitable. This detail is only suitable for walls in dry areas and ceilings in wet or dry areas. Pre-drill a hole using a 6mm dia drill bit for fixing with Fastfix fasteners.

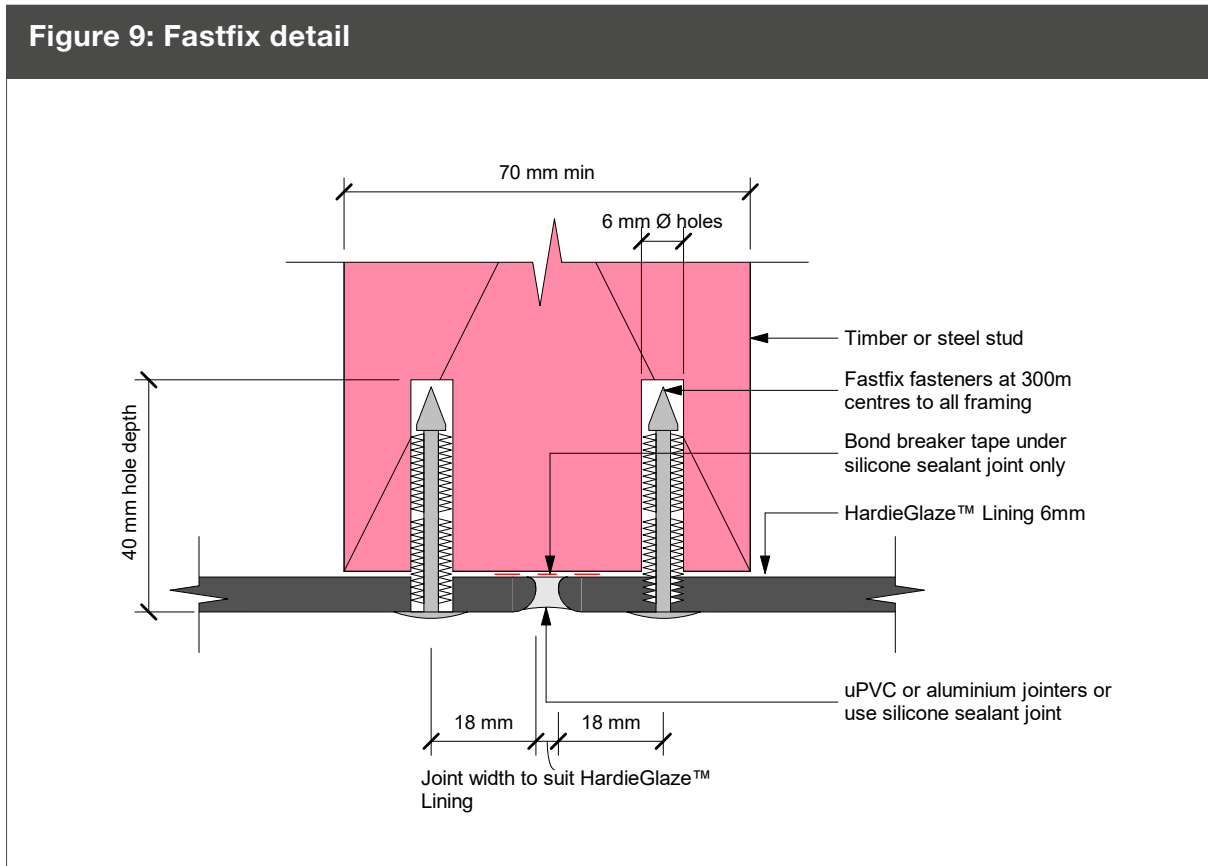

6.8 Raised-Head Screw Fixing Method

HardieGlaze Lining can be fixed with raised-head screws at 300mm centres to all framing (refer Figure 10). This method can be used when removable panels are required. Pre-drill a hole for fixing with a screw. This detail is only suitable for walls in dry areas and ceilings in wet or dry areas.

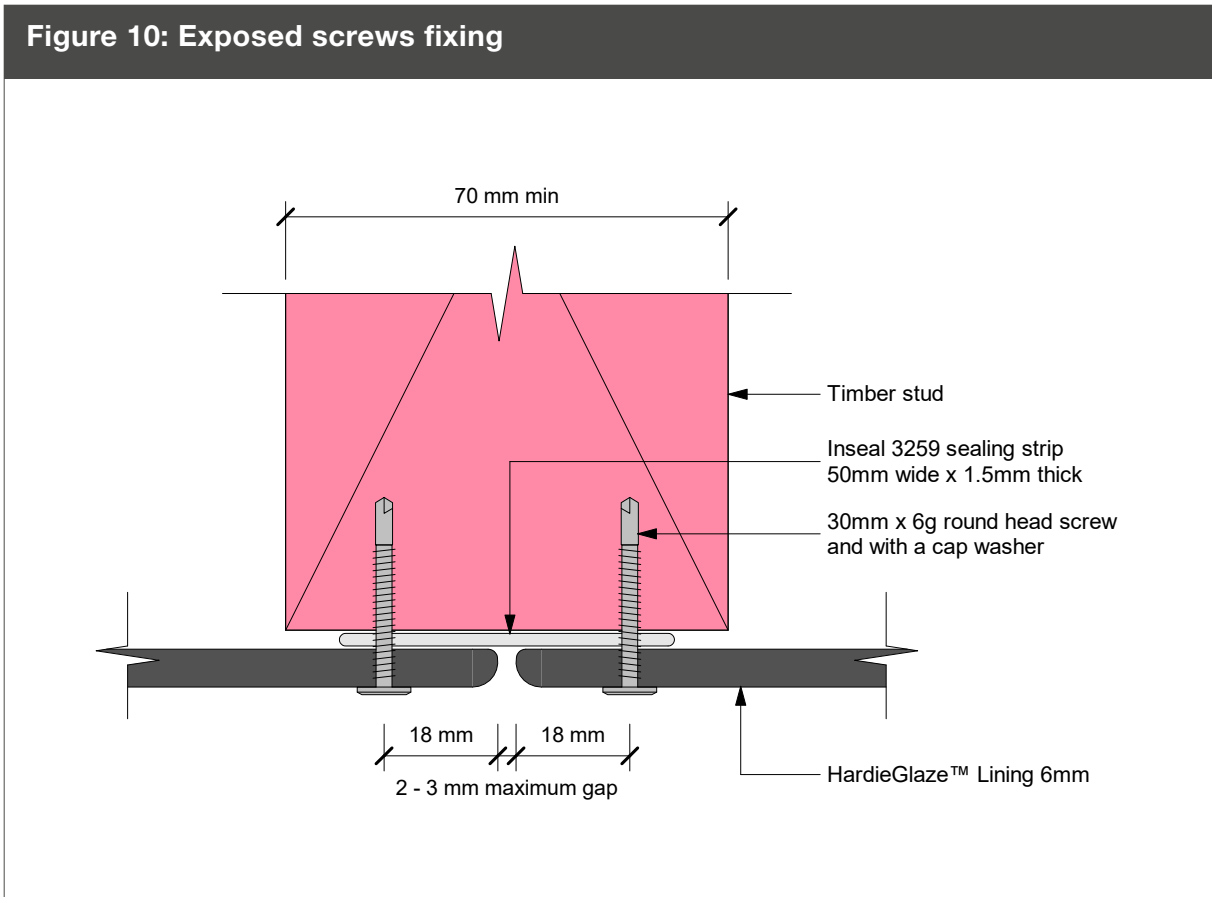

6.9 Sheet Set-out and Shower Rose Location

The vertical set-out of HardieGlaze Lining Tile is important because of its pattern. Choose a horizontal set-out datum line because the module must coincide with the horizontal tile pattern line. Set out all sheets to this. The shower rose must be positioned below any ceramic tile inserts or horizontal sheet joints. This is to stop water from the shower rose running behind the HardieGlaze Lining sheet.

6.10 Fixing to Fibre Cement or Plasterboard Substrate

HardieGlaze Lining can either be fixed directly to the framing or fixed directly over Villaboard Lining by James Hardie or plasterboard lining.

7 Joints

7.1 Dry Area Wall Joints – HardieGlaze Lining

7.1.1 Joints, Corners and Cap

- Fix mouldings at max 300mm centres with nail.
- When using a cap mould, cut the vertical jointer shorter to suit

HardieGlaze Lining 4.5mm

- uPVC or natural anodised aluminium jointers

HardieGlaze Lining 6mm

- uPVC/natural anodised aluminium/powder coated coloured aluminium jointers

Figure 11: HardieGlaze jointer 4.5mm uPVC

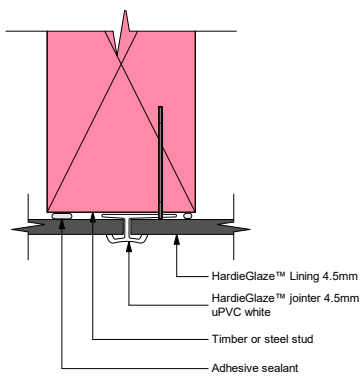

Figure 12: HardieGlaze internal corner 4.5mm uPVC

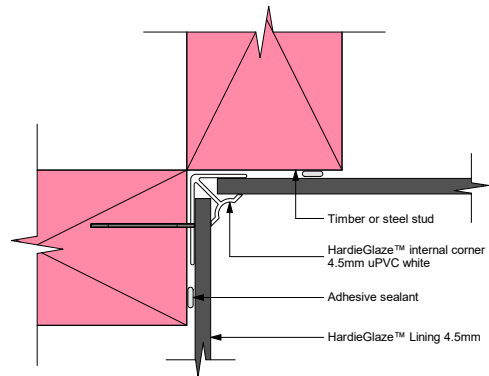
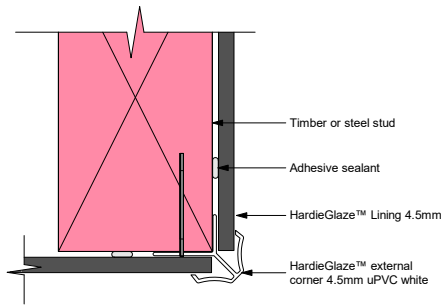

Figure 13: HardieGlaze external corner 4.5mm uPVC



Note: For showers and similar wet areas the uPVC jointer must be silicone-sealant filled

Figure 14: HardieGlaze jointer 4.5mm aluminium

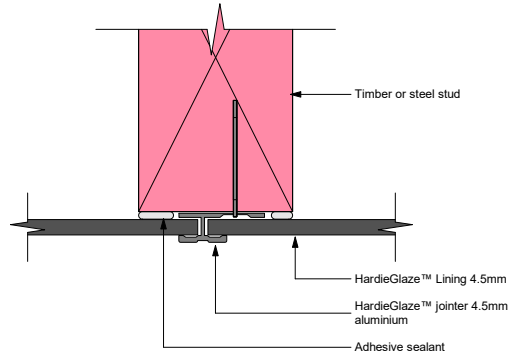

Figure 15: HardieGlaze internal corner 4.5mm aluminium

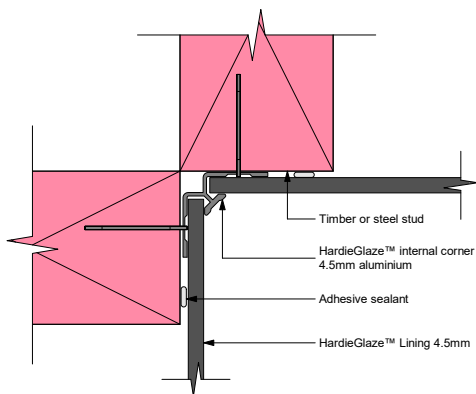
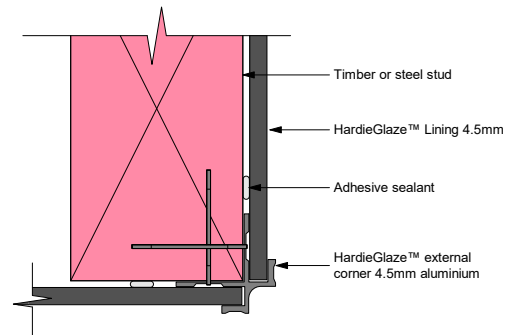

Figure 16: HardieGlaze external corner 4.5mm aluminium



7.1.2 Wall to Ceiling joint

- Use either a timber moulding/cap moulding or James Hardie uPVC scotia mould

Figure 17: HardieGlaze Lining 4.5mm scotia mould options

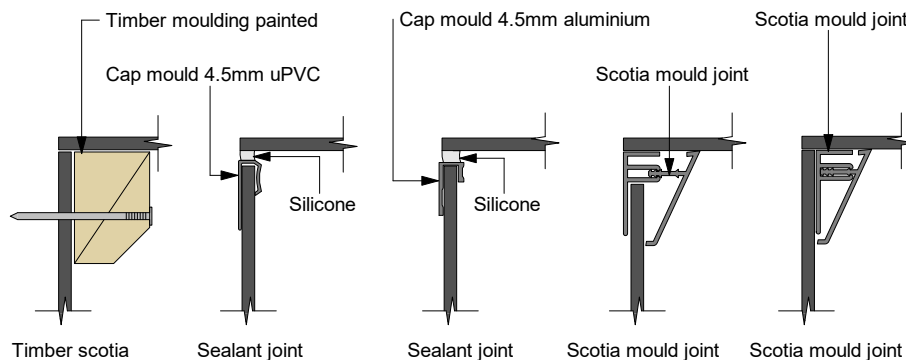

Figure 18: HardieGlaze jointer 6mm uPVC

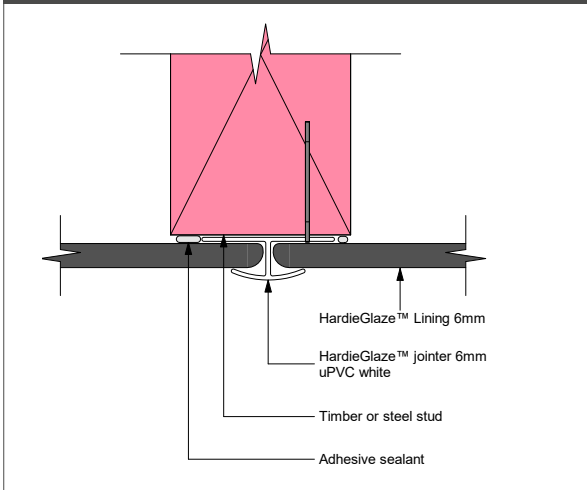

Figure 19: HardieGlaze internal corner 6mm uPVC

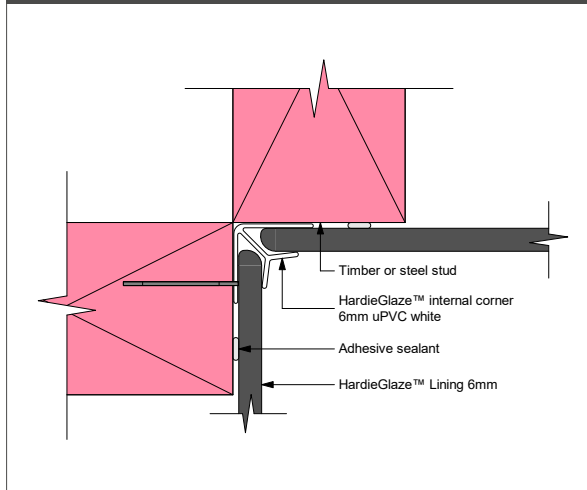

Figure 20: HardieGlaze external corner 6mm uPVC

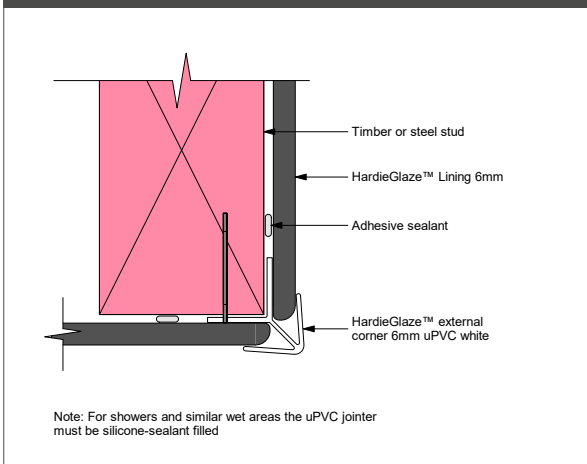

Figure 21: HardieGlaze internal corner 6mm 2part uPVC

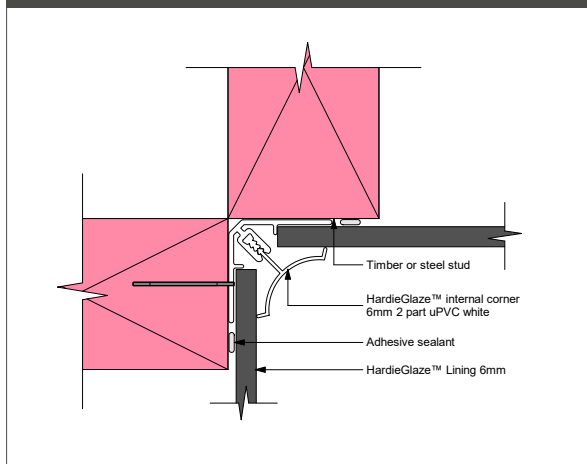

Figure 22: HardieGlaze jointer 6mm aluminium

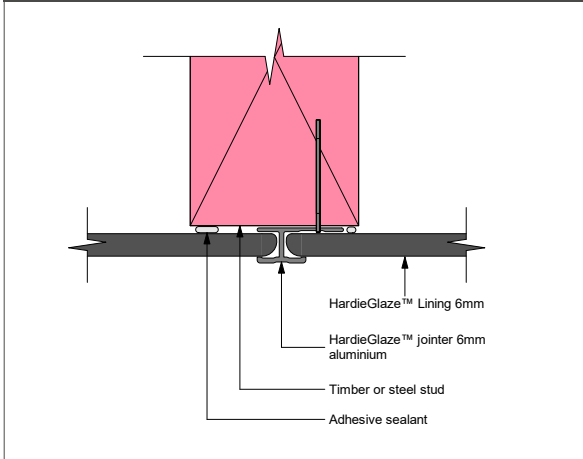

Figure 23: HardieGlaze internal corner 6mm aluminium

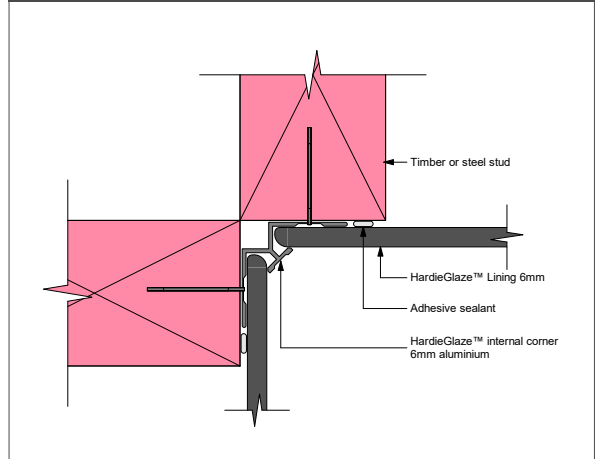

Figure 24: HardieGlaze external corner 6mm aluminium

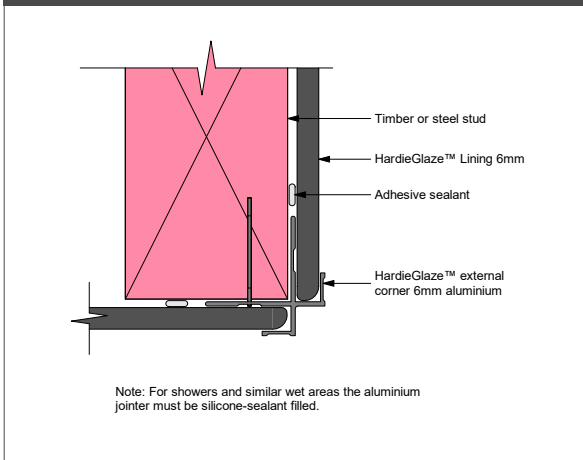
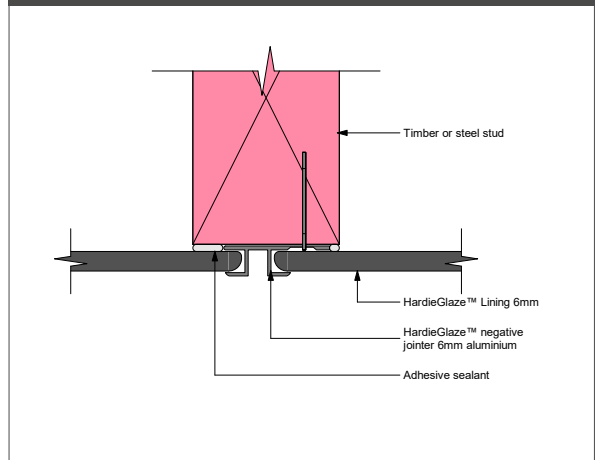

Figure 25: HardieGlaze negative jointer 6mm aluminium



7.2 Silicone Joints

This method only suitable for dry areas.

This method of jointing applies to HardieGlaze Lining 6mm only which has factory radiused edges.

- Fix bondbreaker tape to the framing behind the joints before fixing sheets (refer Figure 26).
- Peel back the protective film from the sheet edge.
- Ensure the sheet edge is prepared for a silicone joint. The factory-painted, radiused sheet edge should be used for all flat joints. (refer Figure 26).
- For an internal corner place the site cut edges sand papered and well primed into corner first, then place factory finished edge 3-4mm from the face of the first sheet.
- Once the sheet edge is prepared, fit the first sheet on one side of the joint, fix a spacer in position at 300mm centres approximately, but do not nail fully in. Place the next sheet on the wall and firmly push onto the spacer to give the correct gap for the silicone joint (refer Figure 26).
- Temporarily brace the edges and centre of the sheet as required. Allow adhesive to be fully cured (as per manufacturer's instructions).
- Accurately mask each side of the joint with the recommended masking tape. Refer Table 5. Incorrect tapes can cause coating removal.
- Prime the joint to be silicone sealed according to the manufacturer's instructions.
- Apply the silicone sealant, neatly finish and remove the masking tape only when all sealant operations are complete and whilst sealant is still wet.
- Do not touch silicone sealant with bare fingers as this can encourage mould growth. Use a plastic spoon, wear rubber gloves or cover finger with a plastic bag.

Figure 26: HardieGlaze Lining 6mm silicone joint

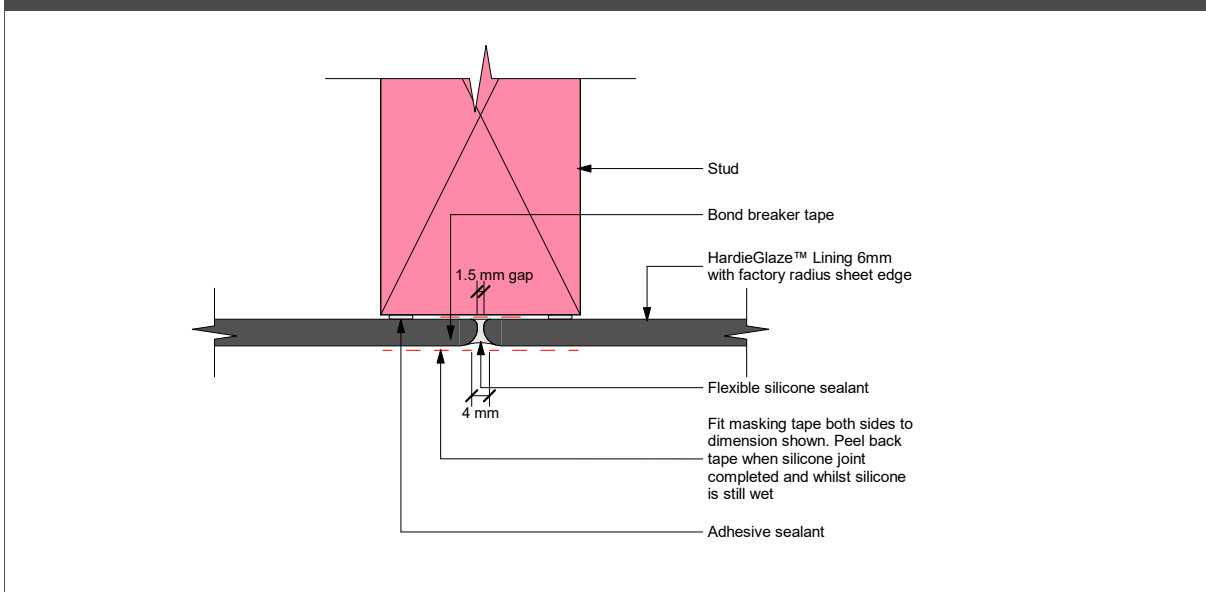

Sealant notes:

1. Cut edges must be site sealed with Dulux 1 Step, Dulux Acraprime 501/1 or similar before sealant is applied.
2. Silicone seal the joint. For full application instructions refer to the sealant manufacturer. Suitable sealants are listed in Table 8.

7.2.2 Wall to Ceiling joint

- Use either a timber moulding/cap moulding or James Hardie uPVC scotia mould

Figure 27: HardieGlaze Lining 6mm scotia mould options

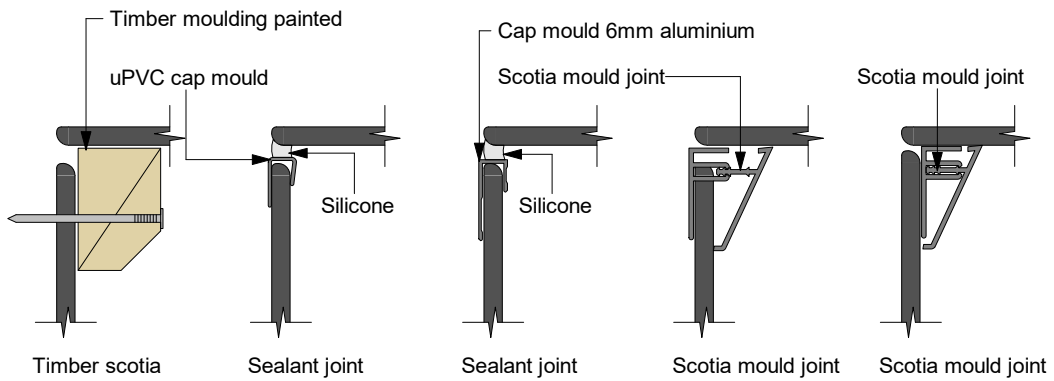

7.3 Wet Area Wall Joints – HardieGlaze Lining

When the uPVC or aluminium jointer method is used for wet area applications, ensure that all the sheet edges have been sealed into jointers with a silicone sealant.

A sealant only joint must not be used in shower applications.

7.3.1 Joints, Corners and Cap

Fix mouldings at max 300mm centres with nail.

When using a cap mould, cut the vertical jointer shorter to suit

HardieGlaze Lining 4.5mm

- uPVC or natural anodised aluminium jointers

HardieGlaze Lining 6mm

- uPVC/natural anodised aluminium/powder coated coloured aluminium jointers

Figure 28: HardieGlaze jointer 4.5mm uPVC

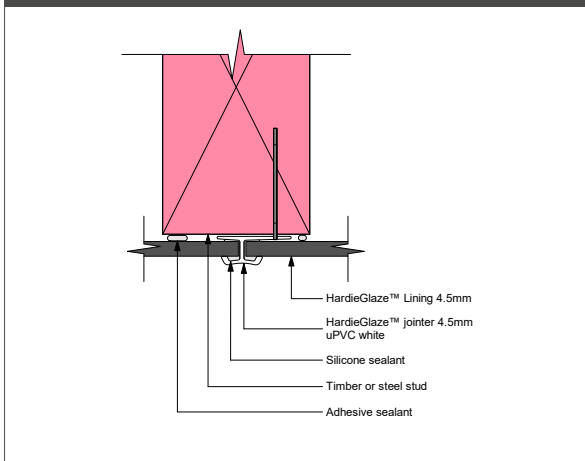

Figure 29: HardieGlaze internal corner 4.5mm uPVC

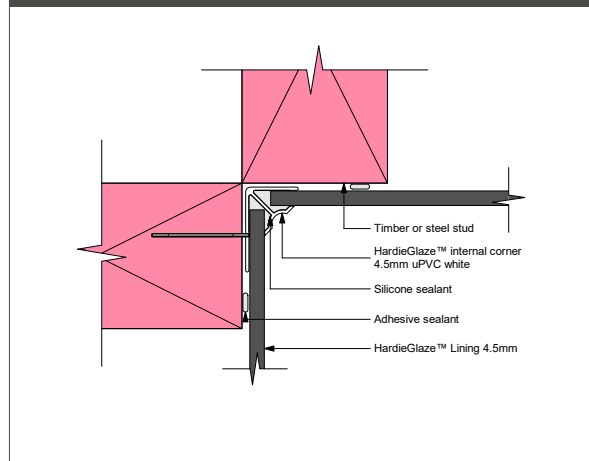

Figure 30: HardieGlaze jointer 4.5mm aluminium

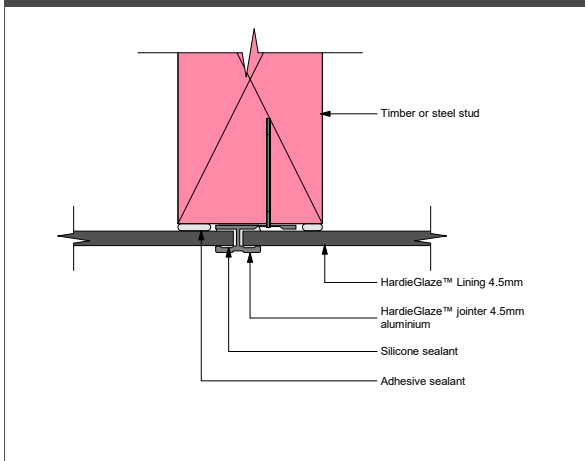

Figure 31: HardieGlaze internal corner 4.5mm aluminium

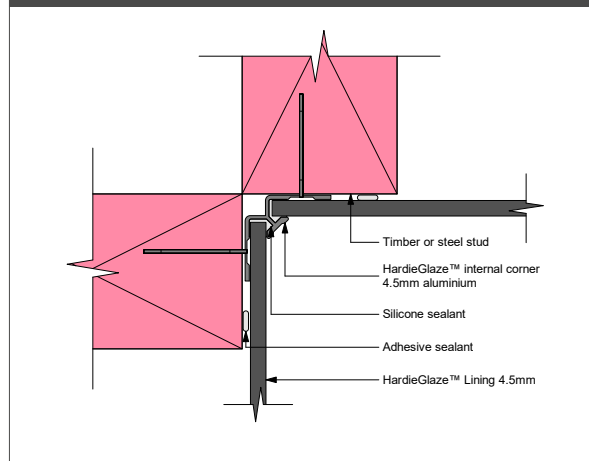
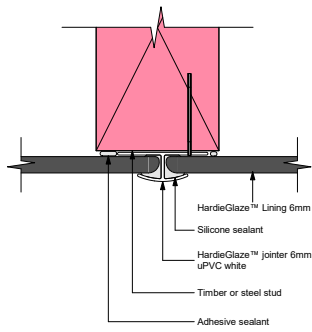

Figure 32: HardieGlaze jointer 6mm uPVC



1. Silicone seal the joint. For full application instructions refer to the sealant manufacturer.
2. The silicone joint is suitable only for radused edge sheets - HardieGlaze Lining Tile and HardieGlaze Lining 6mm. Do not touch silicone with a bare finger.

Figure 33: HardieGlaze internal corner 6mm uPVC

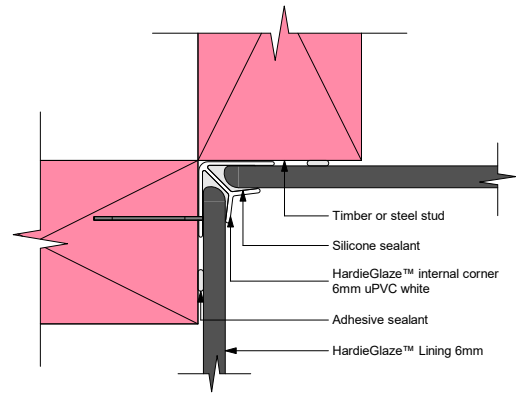

Figure 34: HardieGlaze internal corner 6mm 2part uPVC

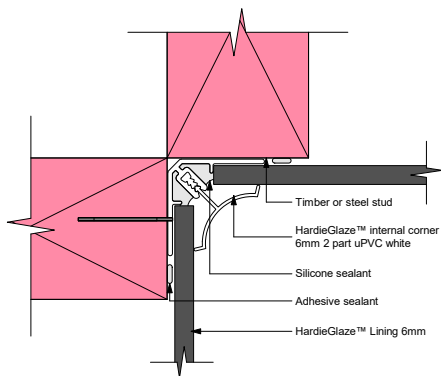

Figure 35: HardieGlaze jointer 6mm aluminium

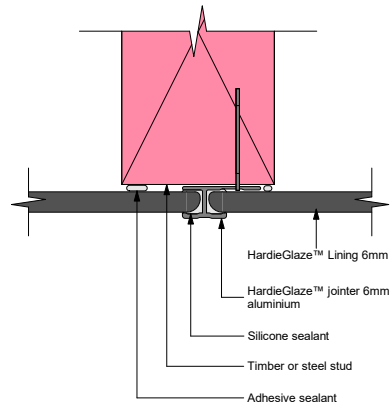

Figure 36: HardieGlaze internal corner 6mm aluminium

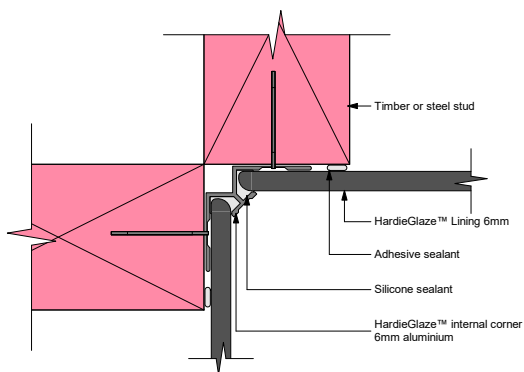
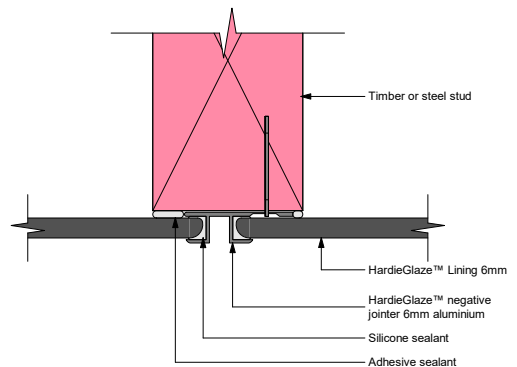

Figure 37: HardieGlaze negative jointer 6mm aluminium



Penetrations:

- Seal all fittings and penetrations through HardieGlaze Lining with a silicone or similar sealant. Use flanges/face plates to cover the penetrations.
- Ensure that adequate moisture management is achieved for the details not covered in this manual. Refer to designer for the details.

Around baths and showers:

- Around baths the silicone detail or uPVC bath mould to be used.

Figure 38: HardieGlaze Lining Bath sealant detail

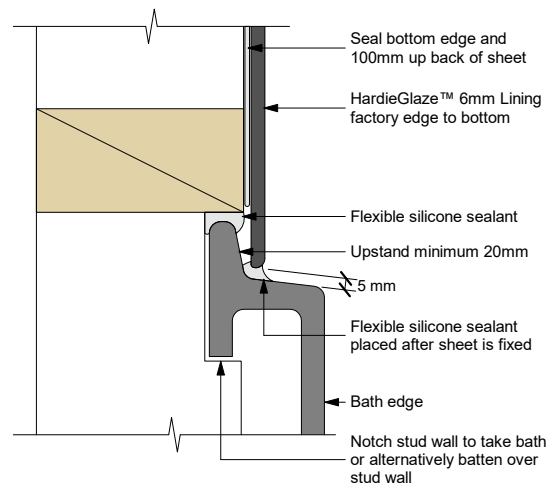

Figure 39: HardieGlaze Lining Bath Mould uPVC

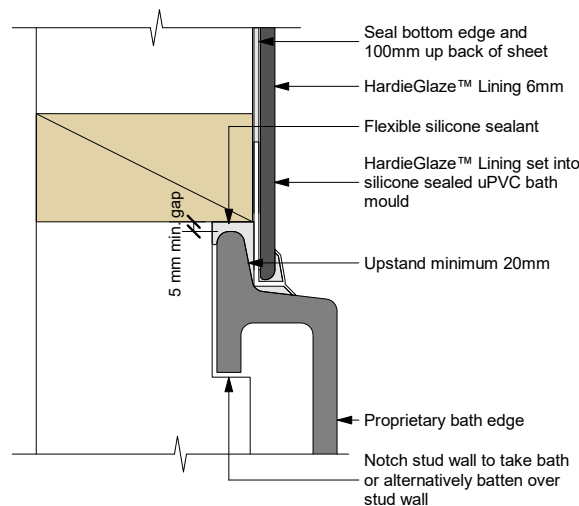
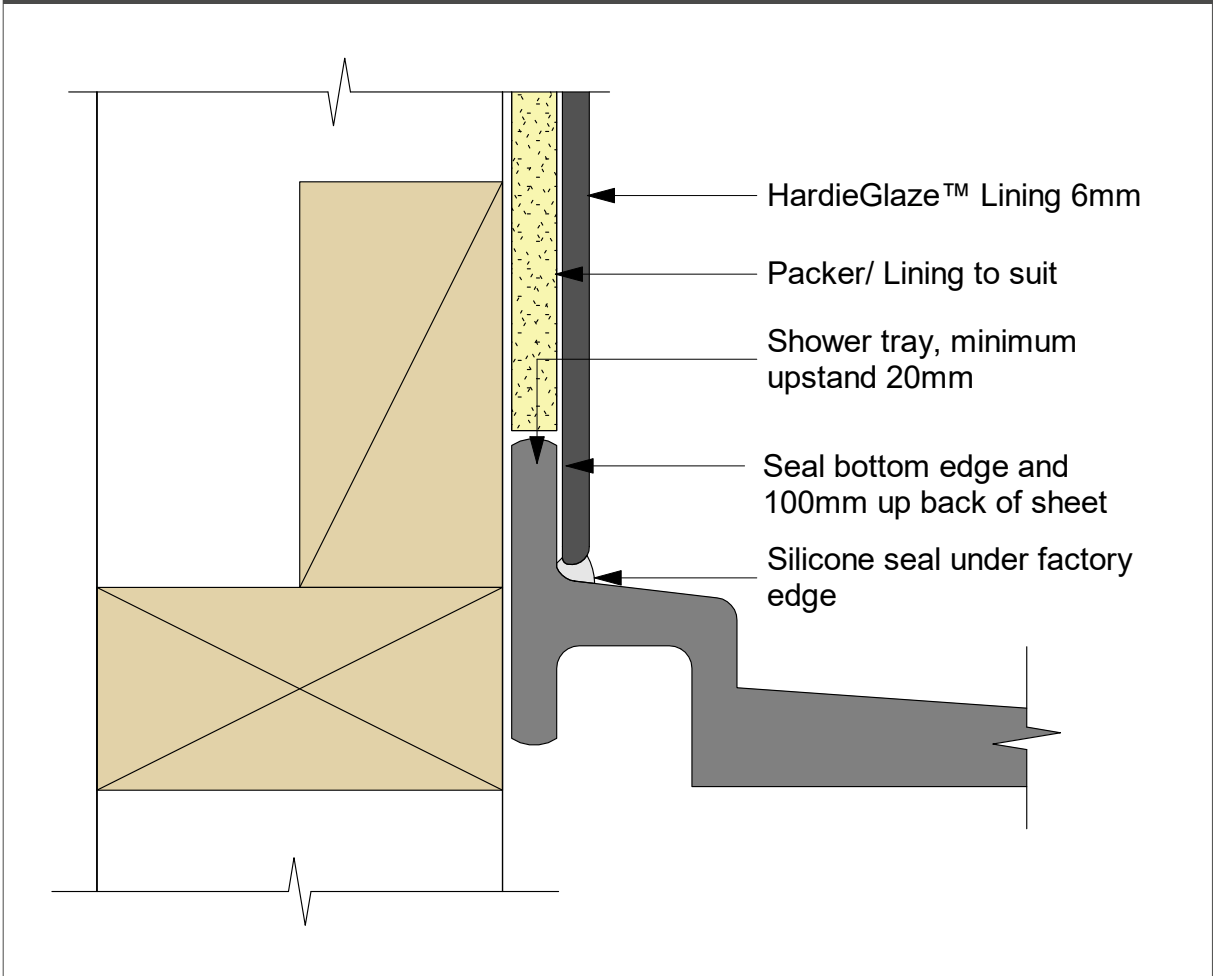

Figure 40: HardieGlaze Lining sealant bath acrylic shower detail



7.3.2 Wet area wall-to-floor joints

- Refer to figures for these junctions
- For a stainless-steel shower installation it is essential that a drip edge is formed at the bottom of the sheet (refer Figure 47).

Figure 41: HardieGlaze Lining Stainless steel shower tray

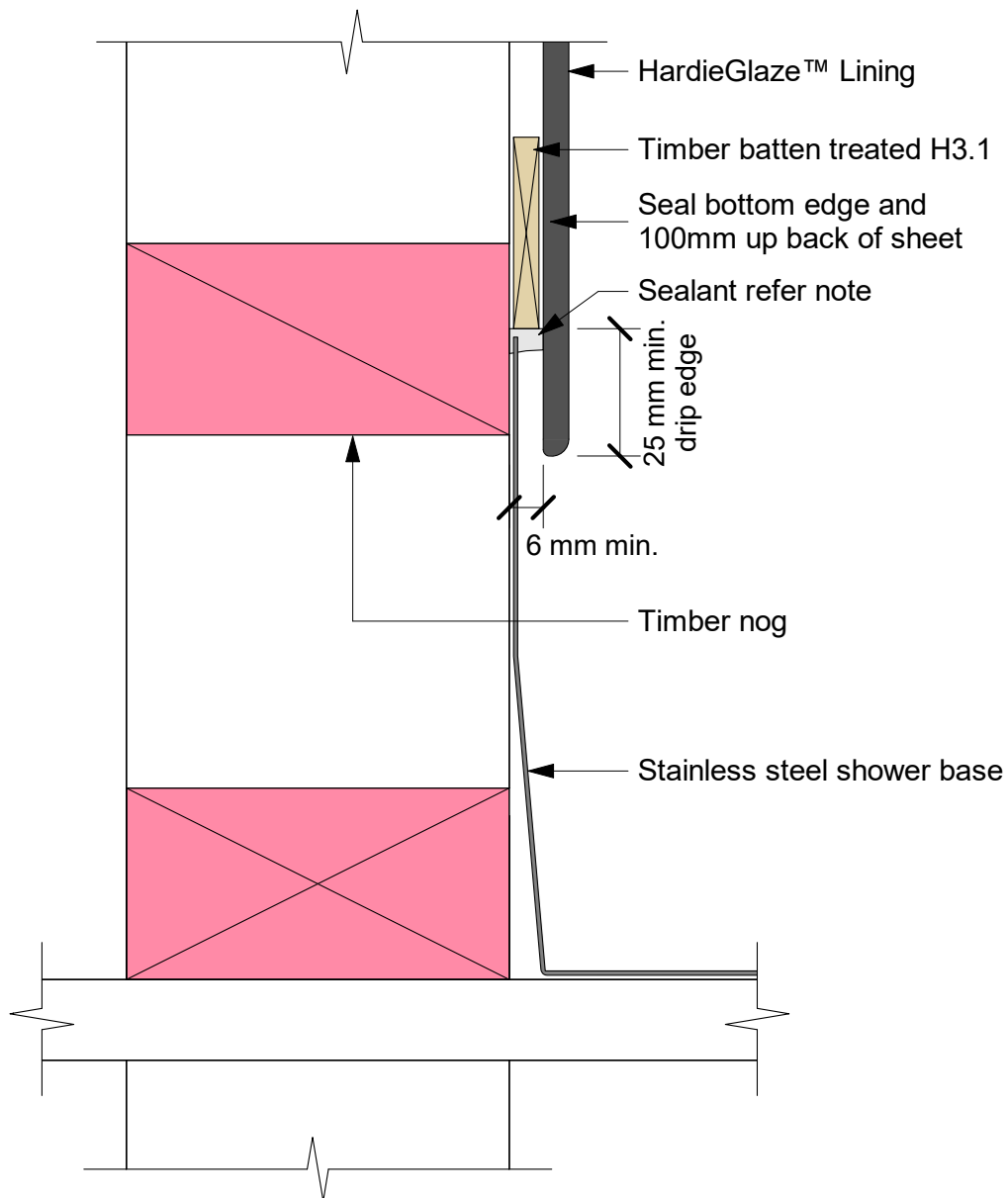

Notes:

It is important to use sealant here to prevent possible damage to the framing.

Note: The shower tray can be notched into the stud to eliminate battening.

Figure 42: HardieGlaze Lining wall to tiled floor

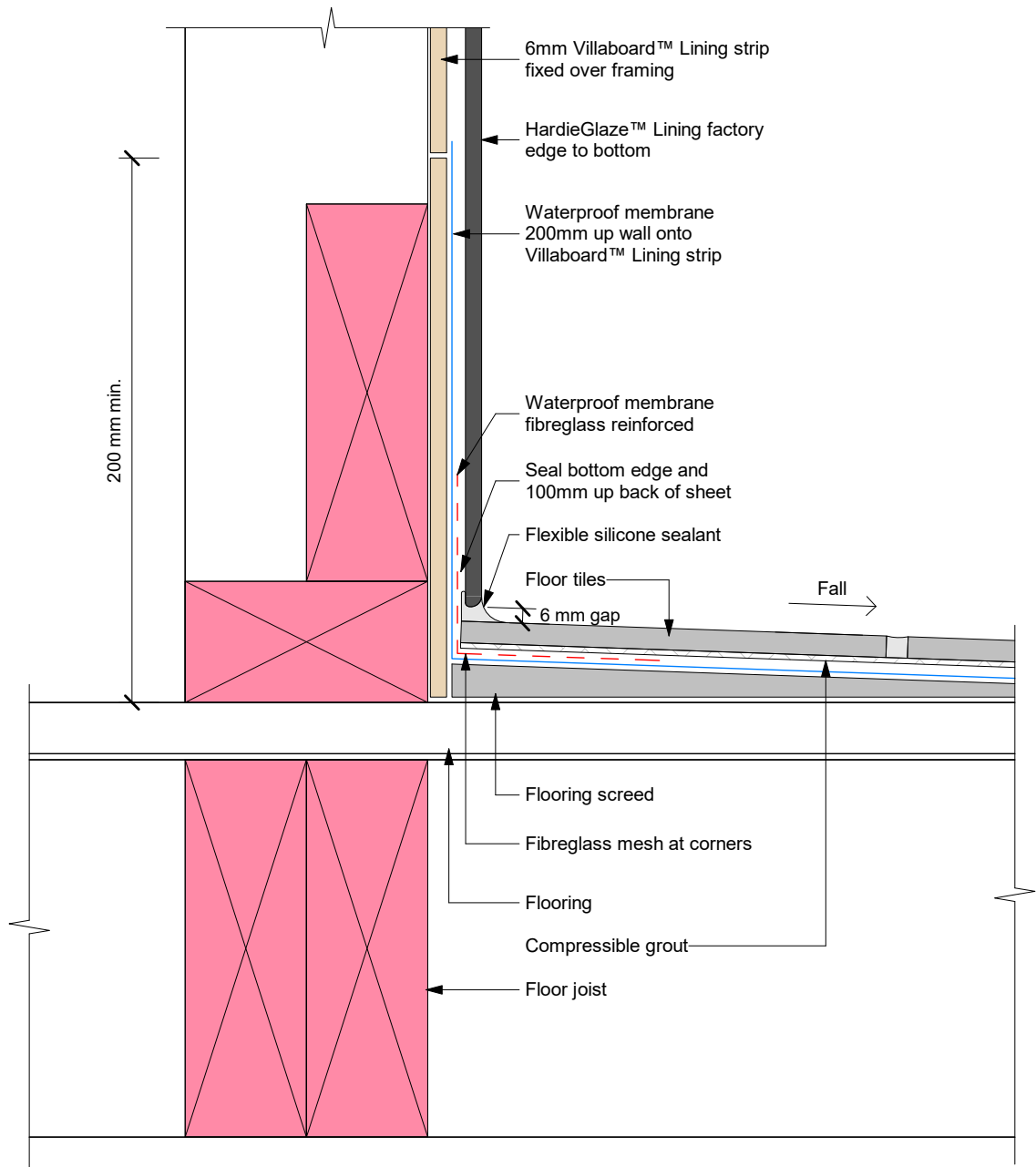

- Notes:**
1. Floor to be laid with two directional falls to corner waste. Perimeter edge of waste hole must be a minimum of 50mm from edge of sheet or wall. Build up falls around waste hole before applying waterproof membrane.
 2. Tiles to be laid prior to HardieGlaze™ Lining installation.

Note: Tiles to be laid prior to HardieGlaze Lining installation

Figure 43: HardieGlaze Lining wall to tiled floor and upstand detail

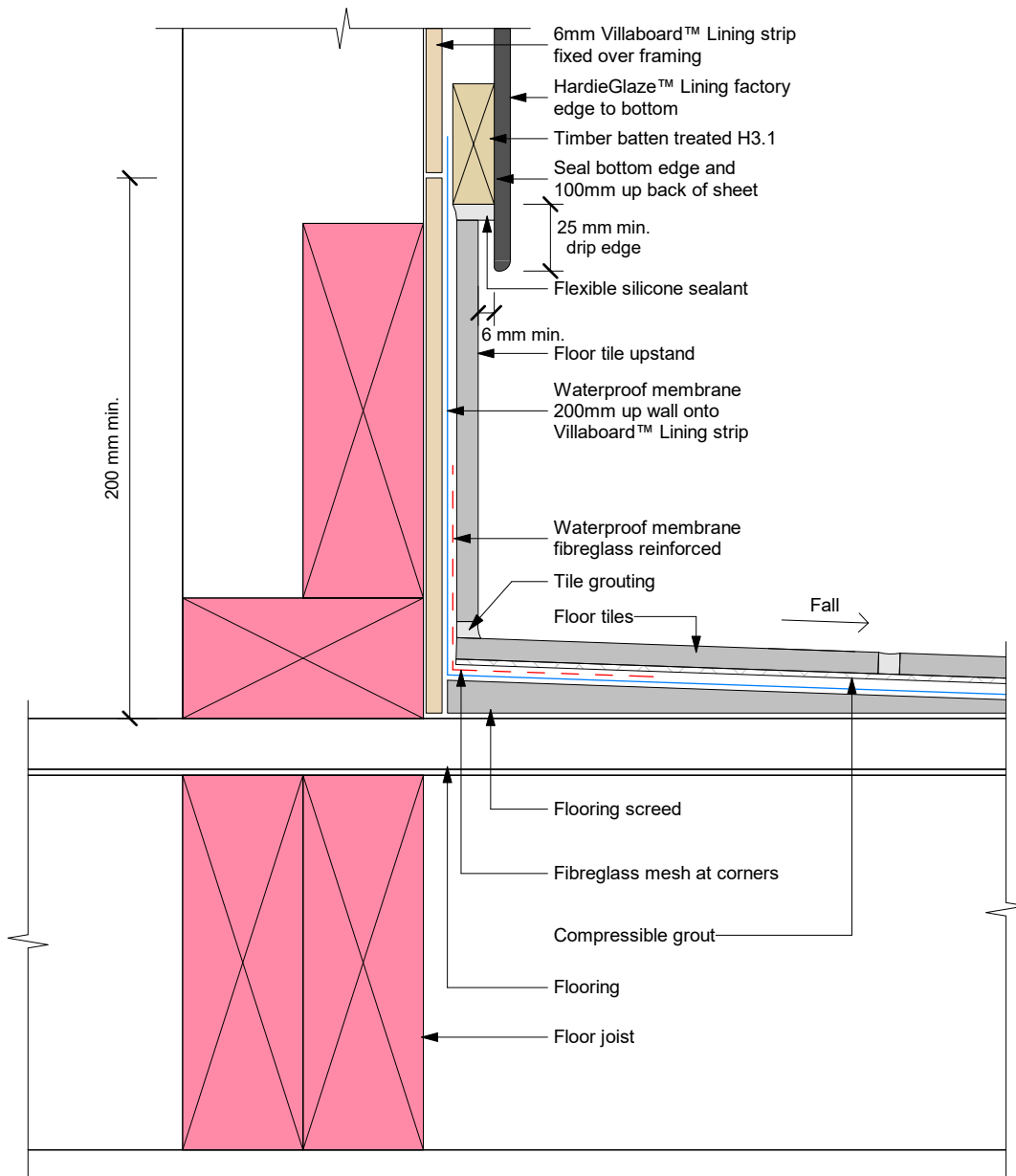

Notes:

1. Perimeter edge of waste hole must be a minimum of 50mm from edge of sheet or wall. Build up falls around waste hole before applying waterproof membrane.
2. Tiles to be laid prior to HardieGlaze™ Lining installation.

Note: Tiles to be laid prior to HardieGlaze Lining installation

Figure 44: HardieGlaze Lining to coved vinyl floor

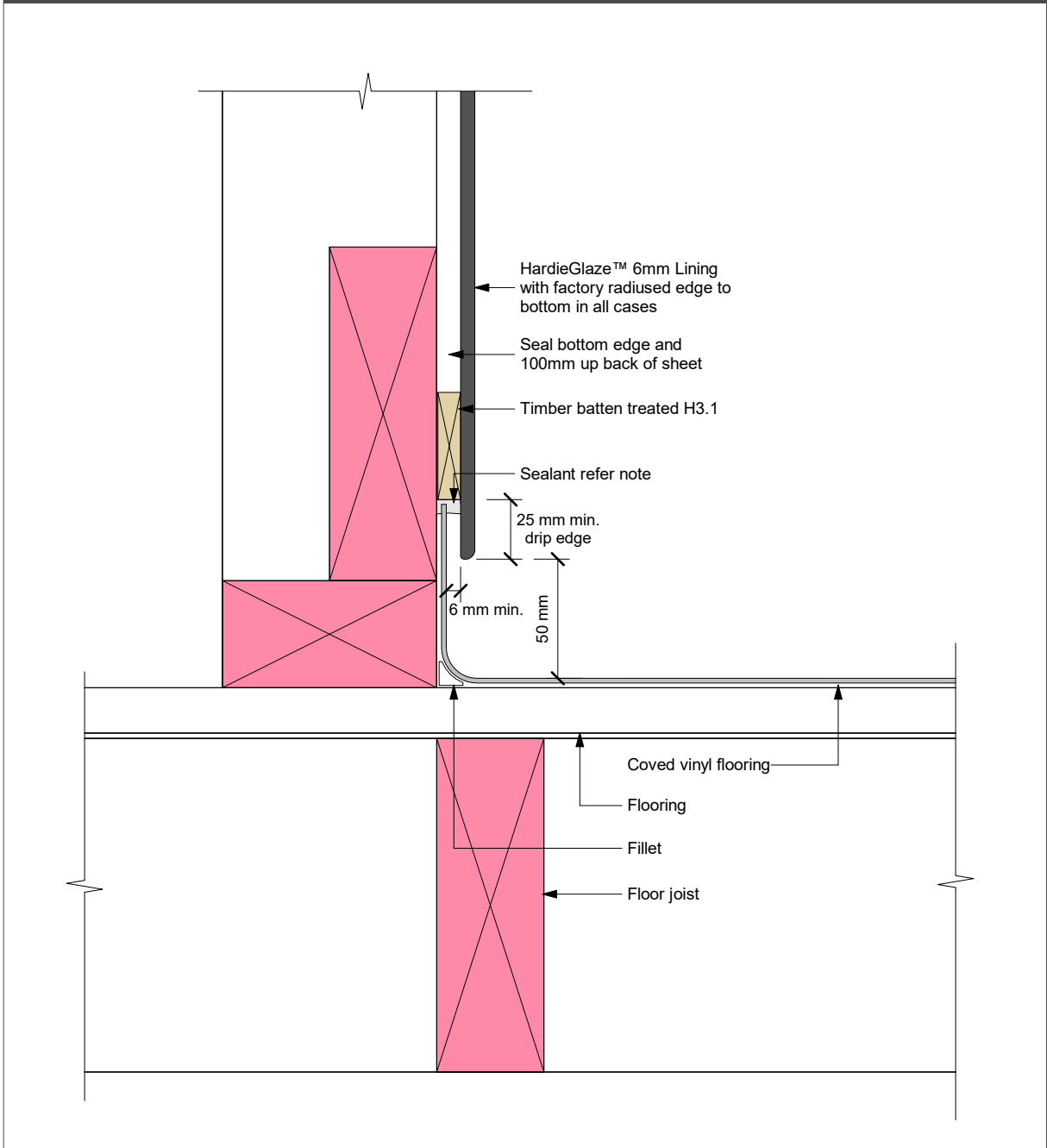

Note: It is important to use sealant here to prevent possible damage to the framing.

8 Special Applications

8.1 Indoor Swimming Pool Applications

A chlorine environment is not suitable for some wallboard adhesives therefore when using HardieGlaze Lining in areas such as indoor swimming pool areas, check with the adhesive manufacturer regarding their suitability in this application or use stainless steel screws with cup washers. It is recommended that a higher level of timber treatment is used for timber framing in this environment.

HardieGlaze Lining must be cleaned more frequently when used in a chlorine environment.

8.2 Splashback

HardieGlaze Lining can be used as a splashback.

Minimum clearance to gas hob being 200mm must be maintained from the closest outer ring of hob.

Minimum clearance to electric element being 100mm must be maintained from the closest outer ring of element.

Figure 45: Splashback clearance

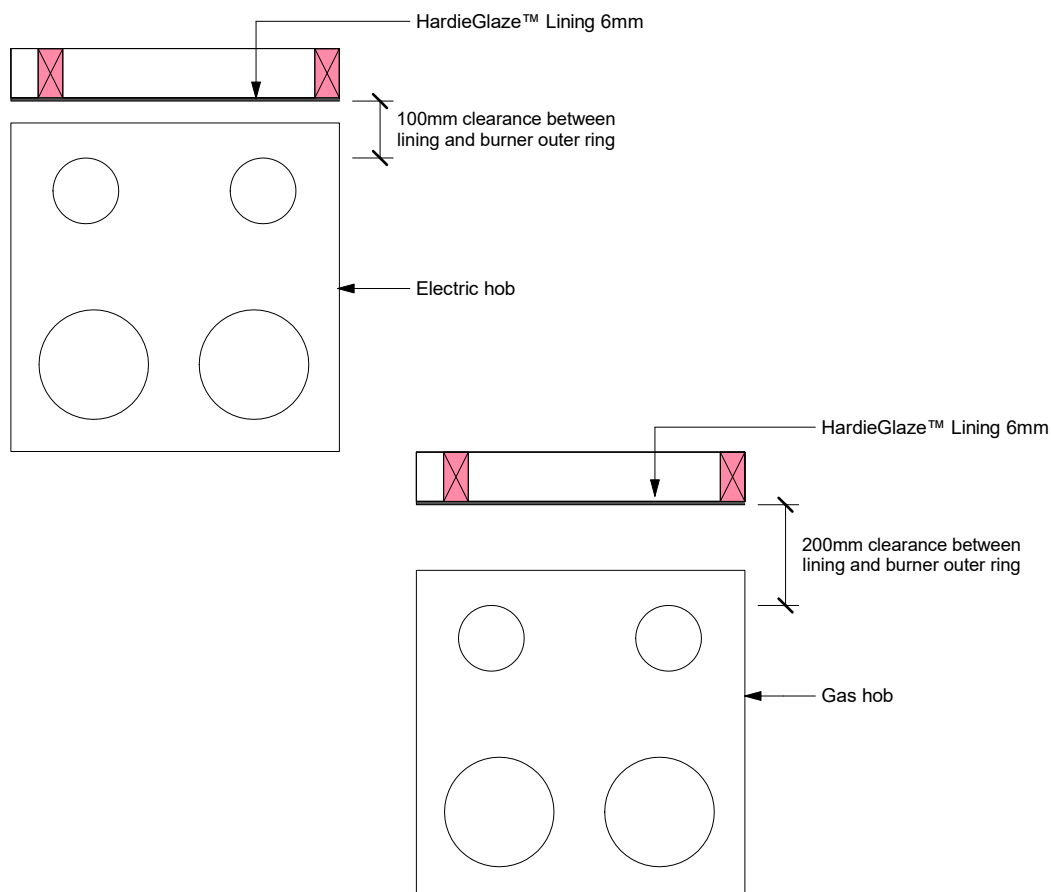

8.3 Wet Area Penetration

Wet area wall caddy can also be used with HardieGlaze Lining.

Figure 46: Optional wet wall caddy

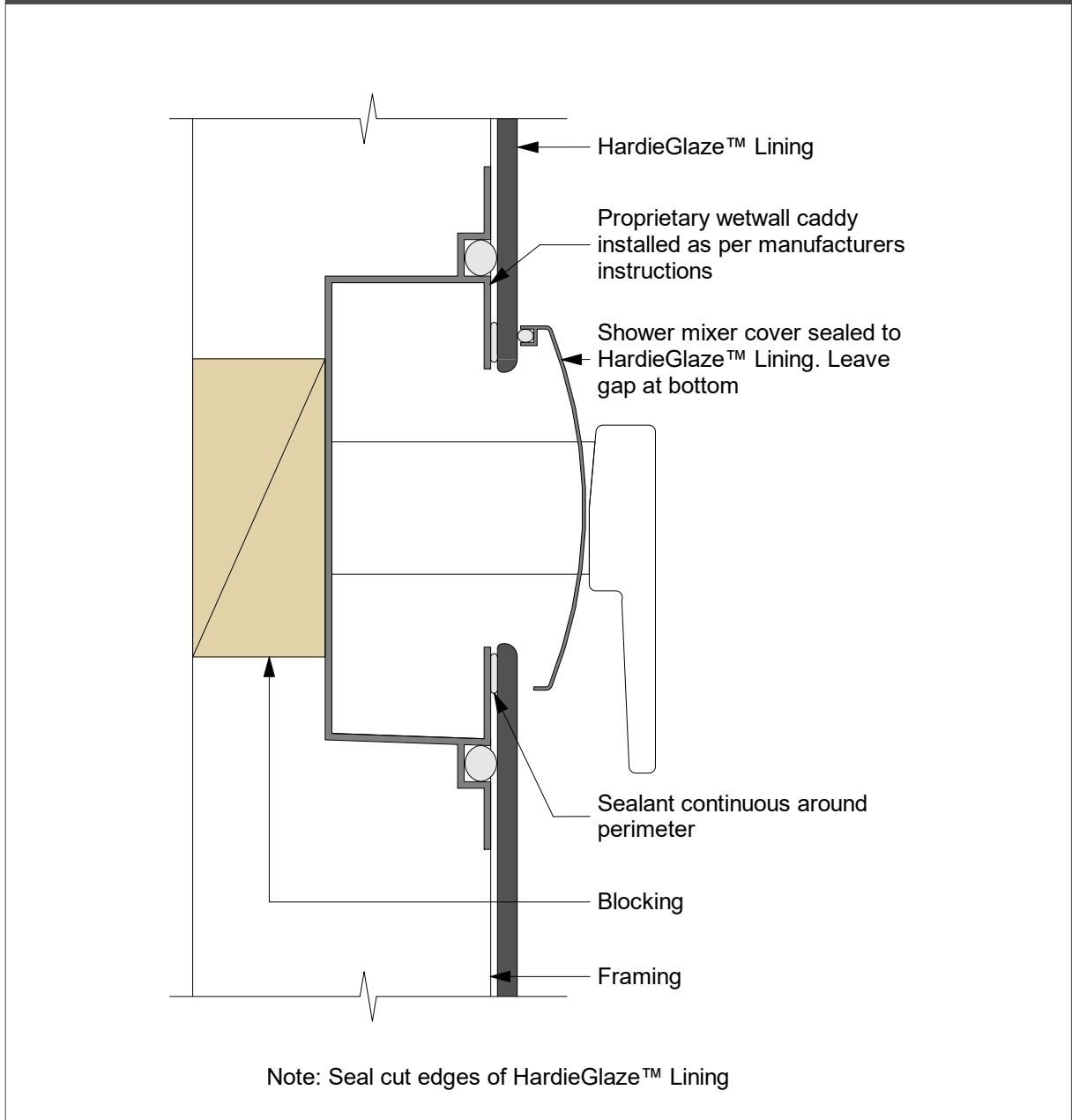

8.4 Sealants

All sealants must demonstrate the ability to meet the relevant requirements of the NZBC and hold a current BRANZ Appraisal. Application and use of sealants must comply with manufacturer's instructions. Sealants, if coated, must be compatible with the paint system.

9 Care and Maintenance

9.1 General

HardieGlaze Lining is resistant to damage from moisture, the sheet must still be installed and maintained to resist the penetration of moisture. It is important that the sealants and jointers are prevented from any damage to ensure that water doesn't penetrate behind HardieGlaze Lining.

Regular inspections are required to determine whether any system components need replacing. Refer to cleaning recommendation in clause 10.2.

9.2 Cleaning procedures

HardieGlaze Lining is low maintenance and easy to clean, in order to keep its appearance and performance, we recommend the following cleaning guidelines:

- Always adhere to cleaning manufacturer's instructions
- Always use non-abrasive soft cloths
- No abrasive liquid or cream cleaners should be used if needed
- Do not use scouring pads or abrasive cloths or cleaners (e.g. steel wool) as these can damage the surface
- The removal of dust from the surface of HardieGlaze Lining can be easily achieved with the use of an electrostatic dusting cloth

Product Warranty

James Hardie New Zealand Limited (“James Hardie”) warrants to the first purchaser of the Product for a period of 15 years from the date of purchase that the HardieGlaze™ Lining (the “Product”), will be free from defects due to defective factory workmanship or materials and, subject to compliance with the conditions below, will be resistant to cracking, rotting, fire and damage from termite attacks to the extent set out in James Hardie’s relevant published literature current at the time of installation. James Hardie warrants for a period of 15 years from the date of purchase that the accessories supplied by James Hardie to be used in conjunction with the Product will be free from defects due to defective factory workmanship or materials.

Nothing in this document shall exclude or modify any legal rights a customer may have under the Consumer Guarantees Act or otherwise which cannot be excluded or modified at law.

CONDITIONS OF WARRANTY:

The warranty is strictly subject to the following conditions:

- a) James Hardie will not be liable for breach of warranty unless the claimant provides proof of purchase and makes a written claim either within 30 days after the defect would have become reasonably apparent or, if the defect was reasonably apparent prior to installation, then the claim must be made prior to installation;
- b) this warranty is not transferable;
- c) the Product must be installed and maintained strictly in accordance with the relevant James Hardie literature current at the time of installation and must be installed in conjunction with the components or products specified in the literature. To obtain copies of such literature please contact ‘Ask James Hardie™ 0800 808 868’. Further, all other products, including coating and jointing systems, applied to or used in conjunction with the Product must be applied or installed and maintained strictly in accordance with the relevant manufacturer’s instructions and good trade practice;
- d) the project must be designed and constructed in strict compliance with all relevant provisions of the current New Zealand Building Code (“NZBC”), regulations and standards;
- e) the claimant’s sole remedy for breach of warranty is (at James Hardie’s option) that James Hardie will either supply replacement product, rectify the affected product or pay for the cost of the replacement or rectification of the affected product;
- f) James Hardie will not be liable for any losses or damages (whether direct or indirect) including property damage or personal injury, consequential loss, economic loss or loss of profits, arising in contract or negligence or howsoever arising. Without limiting the foregoing James Hardie will not be liable for any claims, damages or defects arising from or in any way attributable to poor workmanship, poor design or detailing, settlement or structural movement and/or movement of materials to which the Product is attached, incorrect design of the structure, acts of God including but not limited to earthquakes, cyclones, floods or other severe weather conditions or unusual climatic conditions, efflorescence or performance of paint/coatings applied to the Product, normal wear and tear, growth of mould, mildew, fungi, bacteria, or any organism on any Product surface or Product (whether on the exposed or unexposed surfaces);
- g) all warranties, conditions, liabilities and obligations other than those specified in this warranty are excluded to the fullest extent allowed by law;
- h) if meeting a claim under this warranty involves re-coating of Products, there may be slight colour differences between the original and replacement Products due to the effects of weathering and variations in materials over time.

Disclaimer: The recommendations in James Hardie’s literature are based on good building practice, but are not an exhaustive statement of all relevant information and are subject to conditions (c), (d), (f) and (g) above. James Hardie has tested the performance of HardieGlaze™ Lining when installed in accordance with the HardieGlaze™ Lining installation manual, in accordance with the standards and verification methods required by the NZBC and those test results demonstrate the product complies with the performance criteria established by the NZBC. However, as the successful performance of the relevant system depends on numerous factors outside the control of James Hardie (e.g. quality of workmanship and design) James Hardie shall not be liable for the recommendations made in its literature and the performance of the relevant system, including its suitability for any purpose or ability to satisfy the relevant provisions of the NZBC, regulations and standards, as it is the responsibility of the building designer to ensure that the details and recommendations provided in the relevant James Hardie installation manual are suitable for the intended project and that specific design is conducted where appropriate.

Copyright 2021. © James Hardie New Zealand Limited. TM and ® denotes a Trademark or Registered Mark owned by James Hardie Technology Limited.

HardieGlaze™
LINING

