

# Installation Manual

# Content

1	INTRODUCTION	2
2	SAFE WORKING PRACTICES	4
2.1	Stay healthy when working with building products containing crystalline silica	4
2.2	Avoid breathing in crystalline silica dust!	4
2.3	Storage & delivery	5
2.4	Tips for safe and easy handling	5
3	FRAMING	6
3.1	General	6
3.2	Timber	6
3.3	Steel	6
3.4	Preparation	6
4	INSTALLATION	6
4.1	Sheet Layout	6
4.2	Fasteners	6
4.3	Fixing to Walls	7
4.4	Full Sheet Fixing	7
4.5	Dado Height Fixing	7
4.6	Fixing over Plasterboard Lining	8
4.7	Fixing to Ceilings and Soffits	8
4.8	Fixing to Masonry Substrates	9
5	JOINTING AND CORNERS	9
5.1	Butt Joints	9
5.2	Corners	9
6	PRODUCT INFORMATION	10
6.1	General	10
6.2	Product Mass	10
6.3	Durability	10
6.4	Fire Properties	10
6.5	Finishes	10
6.6	Maintenance	10
	PRODUCT WARRANTY	11

# 1 Introduction

HardieGroove™ Lining combines the appearance of traditional timber tongue and groove wall panelling with the benefits of modern fibre cement.

Because the baseboard is James Hardie fibre cement, it's resistant to fire and damage from moisture, rotting and termites when installed and maintained as directed.

HardieGroove Lining has decorative v-shaped grooves carved into the front face of the 7.5mm sheet, and is sanded, ready to be painted in any colour.

HardieGroove Lining can be fixed to the full height of the wall or at dado height to create a decorative, hard-wearing, impact resistant lining in hallways and to withstand the toughest treatment in family rooms, rumpus rooms, laundries and bathrooms (not suitable for shower areas).

HardieGroove Lining is also ideal for use in ceilings, either to add interest to a modern design, or to create historical detail on a renovation project.

The main features of HardieGroove Lining are:

- Durable internal lining, soffit and ceiling sheet.
- Creates suitable surface for paint finish.
- Sheet edges have a 'half groove' to achieve concealed sheet joints.
- Reliable impact resistant decorative lining. Ideal for wall lining where walls are prone to damage.
- Resistance to damage from moisture making it ideal for bathrooms, laundries and kitchens.
- Joints won't pull or shift apart.
- Authentic v-shaped grooves replicate traditional tongue and groove look and style.
- Ideal as feature wall to dado height.

The specifier or other responsible party for the project must ensure the information and details in this guide are appropriate for the intended application and specific design and detailing is undertaken for areas which fall outside the scope of this documentation.

## **Make sure your information is up to date**

When specifying or installing James Hardie products, ensure you have the current manual. If you're not sure you do, or if you need more information, visit [www.jameshardie.co.nz](http://www.jameshardie.co.nz) or Ask James Hardie™ on 0800 808 868.

## **WE VALUE YOUR FEEDBACK**

To continue with the development of our products and systems, we value your input. Please send any suggestions, including your name, contact details, and relevant sketches to:

### **Ask James Hardie™**

Fax 0800 808 988

[literaturefeedback@jameshardie.co.nz](mailto:literaturefeedback@jameshardie.co.nz)

Table 1

Product	Description	Description
		<p>HardieGroove Lining is a v-grooved internal lining board with the look of timber and the durability of fibre cement.</p> <p>Individual batten widths are 100mm</p> <p>Sheet sizes:</p> <p>2400mm x 1200mm x 7.5mm Product code <b>400246</b></p> <p>2700mm x 1200mm x 7.5mm Product code <b>400245</b></p> <p>3000mm x 1200mm x 7.5mm Product code <b>404917</b></p>

Table 2







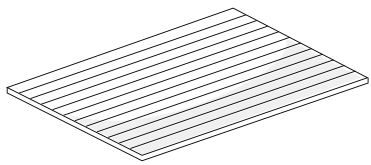
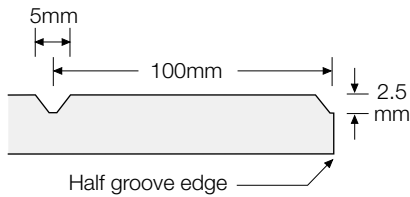



Product/Accessories/Tools supplied by James Hardie					
Product	Description	Product Code	Product	Description	Product Code
	HardieBlade™ Saw Blade 184mm diameter, poly diamond blade, for fast, clean cutting of James Hardie fibre cement.	<b>300660</b>		FibreTEKS® Screw For fastening to 0.75mm to 1.0mm BMT steel frames. Class 3 finish. Length: 30mm x 9g ® denotes a registered mark of Buildex	1000/box <b>303840</b>
	James Hardie Base Coat For finishing fastener heads. Volume: 4kg Pail 15kg Bag	<b>304490</b> <b>304491</b>		HardieDrive™ Screw s/s 316 30mm x 7g	100/jar <b>300928</b>
	Soffit Scotia Mould 2 pcs. (base and cap) 2400mm	<b>300916</b>		Villadrive Wood Screw Envirodrab coating. Length: 30mm x 6g	100/jar <b>300992</b>  5kg/box <b>300993</b>  1000 collated <b>300994</b>
	HardieKnife™ Scoring tool for easy cutting.	<b>305926</b>			

Table3

Product/Accessories/Tools not supplied by James Hardie			
James Hardie recommends the following products for use in conjunction with its HardieGroove Lining. James Hardie does not supply these products and does not provide a warranty for their use. Please contact the component manufacturer for information on their warranties and further information on their products.			
	HardieFlex™ nails 40 x 2.8mm galvanised or stainless steel 316 fibre cement nails for fastening to timber.		Fibreshear Electric cutting tool.
	Adhesive Sealant Sika Sikaflex 11FC, Bostik Seal N Flex-1, Fullers Max Bond, Selley's Liquid Nails		Brad Nail ND 50 To be used in conjunction with 6mm bead of adhesive on a stud/nogs. Only suitable for internal walls.

# 2 Safe working practices

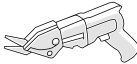
## 2.1 STAY HEALTHY WHEN WORKING WITH BUILDING PRODUCTS CONTAINING CRYSTALLINE SILICA

---

### Crystalline Silica

What is it? Why and when is it a health hazard?

### Crystalline Silica is

- Commonly known as sand or quartz
- Found in many building products e.g. concrete, bricks, grout, wallboard, ceramic tiles, and all fibre cement materials

### Why is Crystalline Silica a health hazard?

- Silica can be breathed deep into the lungs when present in the air as a very fine (respirable) dust
- Exposure to silica dust without taking the appropriate safety measures to minimise the amount being breathed in, can lead to a potentially fatal lung disease – silicosis – and has also been linked with other diseases including cancer. Some studies suggest that smoking may increase these risks.
- The most hazardous dust is the dust you cannot see!

### When is Crystalline Silica a health hazard?







- It's dangerous to health if safety protocols to control dust are not followed when cutting, drilling or rebating a product containing crystalline silica.
- Products containing silica are harmless if intact (e.g. an un-cut sheet of wall board).

**FAILURE TO ADHERE TO OUR WARNINGS, SAFETY DATA SHEETS AND INSTALLATION INSTRUCTIONS WHEN WORKING WITH JAMES HARDIE PRODUCTS MAY LEAD TO SERIOUS PERSONAL INJURY OR DEATH.**

## 2.2 AVOID BREATHING IN CRYSTALLINE SILICA DUST!

---

### Safe working practices

-  NEVER use a power saw indoors or in a poorly ventilated area
-  NEVER dry sweep
-  ALWAYS use M Class extractor unit as a minimum and always hose down with water/wet wipe for clean up
-  NEVER use grinders
-  ALWAYS use a circular sawblade specifically designed to minimise dust creation when cutting fibre cement – preferably a sawblade that carries the HardieBlade™ logo or one with at least equivalent performance.
-  ALWAYS follow tool manufacturers' safety recommendations
-  ALWAYS expose only the minimum required depth of blade for the thickness of fibre cement to be cut
-  ALWAYS wear an approved properly-fitted, approved dust mask (P1 or P2) or respirator

Use one of the following methods based on the required cutting rate:

### BEST

- HardieKnife™
- Hand guillotine
- Fibreshear





### BETTER

- Dust reducing circular saw equipped with HardieBlade™ Saw Blade and M Class extractor unit.





### GOOD

- Dust reducing circular saw with HardieBlade™ Saw Blade

### Working outdoors

-  Make sure you work in a well ventilated area
-  Position cutting station so wind will blow dust away from yourself and others in the working area
-  Cut products with either a HardieKnife or fibre cement shears or, when not feasible, use a HardieBlade™ Saw Blade (or equivalent) and a dust-reducing circular saw attached to a M Class extractor unit
-  When sawing, sanding, rebating, drilling or machining fibre cement products, always:
  - Wear your P1 or P2 mask (correctly fitted in accordance with manufacturers' instructions) and when others are close by, ask them to do the same
  - If you are not clean shaven, then use a powered air respirator with a loose fitting head top.
  - Wear safety glasses
  - Wear hearing protection
  - When others are close by, ask them to do the same.

### Working indoors

-  Never cut using a circular saw indoors
-  Position cutting station in a well ventilated area
-  Cut ONLY using a HardieKnife, hand guillotine or fibreshears (manual, electric or pneumatic)
-  Make sure you clean up BUT never dry sweep. Always hose down with water/wet wipe or use an M Class extractor unit

**IF CONCERN STILL EXISTS ABOUT EXPOSURE LEVELS OR YOU DO NOT COMPLY WITH THE ABOVE PRACTICES, YOU SHOULD ALWAYS CONSULT A QUALIFIED INDUSTRIAL HYGIENIST.**

### Working Instructions

- Refer to Recommended Safe Working Practices before starting any cutting or machining of product.

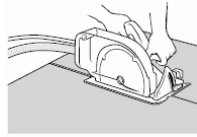

### HardieBlade™ Saw Blade

The HardieBlade™ Saw Blade used with a dust-reducing saw is ideal for fast, clean cutting of James Hardie fibre cement products. A dust-reducing saw uses a dust deflector or a dust collector connected to a vacuum system. When sawing, clamp a straight-edge to the sheet as a guide and run the saw base plate along the straight edge when making the cut.

### Hole-Forming

#### For smooth clean cut circular holes:

- Mark the centre of the hole on the sheet.
- Pre-drill a 'pilot' hole.
- Using the pilot hole as a guide, cut the hole to the appropriate diameter with a hole saw fitted to a heavy duty electric drill.

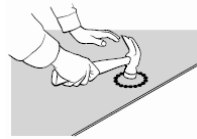

#### For irregular holes:

- Small rectangular or circular holes can be cut by drilling a series of small holes around the perimeter of the hole then tapping out the waste piece from the sheet face.
- Tap carefully to avoid damage to sheets, ensuring that the sheet edges are properly supported.

## 2.3 STORAGE & DELIVERY

### Keeping products and people safe

#### Off loading

- 👍 James Hardie products should be off-loaded carefully by hand or by forklift.
- 👍 James Hardie products should not be rolled or dumped off a truck during the delivery to the jobsite.

#### Storage

##### James Hardie products should be stored:

- 👍 in their original packaging
- 👍 under cover where possible or otherwise protected with a waterproof covering to keep products dry
- 👍 off the ground – either on a pallet or adequately supported on timber or other spacers
- 👍 flat so as to minimise bending

##### James Hardie products must not be stored:

- 👎 directly on the ground
- 👎 in the open air exposed to the elements

**JAMES HARDIE IS NOT RESPONSIBLE FOR DAMAGE DUE TO IMPROPER STORAGE AND HANDLING.**

## 2.4 TIPS FOR SAFE AND EASY HANDLING

### Weatherboard products

- 👍 Do not lift planked products flat and in the middle
- 👍 Carry the products on the edge
- 👍 If only one person is carrying the product, hold it in the middle and spread arms apart to better support the product
- 👍 If two people are carrying the plank, hold it near each end and on edge
- 👍 Exercise care when handling weatherboard products to avoid damaging the edges/corners

### Sheet products

- 👍 Carry with two people
- 👍 Hold near each end and on edge
- 👍 Exercise care when handling sheet products to avoid damaging the edges/corners

# 3 Framing

## 3.1 GENERAL

HardieGroove Lining can be fixed to either timber or light gauge domestic type steel framing. The framing used must comply with the relevant building regulations and standards and the requirements of this manual.

Note: HardieGroove Lining must not be used in shower areas.

## 3.2 TIMBER

Timber framing must comply with the durability requirements of Clause 'B2' of NZBC. Timber must be treated as per the requirements of NZS 3602.

Timber framing sizes and set out must satisfy the minimum requirements of NZS 3604 and this installation guide.

The minimum stud width of 35mm may be used. However, where butt jointing is used the minimum stud width is 45mm at the joint. See Figure 13.

Reference NZS 3604 'Timber Framed Buildings'.

## 3.3 STEEL

The minimum size for steel stud framing should be 64mm deep x 0.55mm base metal thickness (BMT). Steel framing shall comply with NASH 3405 Steel Framed Buildings. Steel sections shall be galvanised or zinc coated of 0.55mm – 1.6mm BMT. Studs must not be less than 38mm wide at butt joints.

Figure 1: Frame straightness



## 3.4 PREPARATION

Ensure frame is square and work from a central datum line. Frames must be straight and true to provide a flush face to receive the sheeting.

A suggested maximum tolerance of between 3mm and 4mm in any 3000mm length of frame will give best results. HardieGroove Lining will not straighten excessively warped or distorted frames and any warping may still be visible after the internal lining is installed.

# 4 Installation

## 4.1 SHEET LAYOUT

HardieGroove Lining is usually fixed vertically. Sheet joints must coincide with the centre line of the framing member.

The long edges of the sheet have a unique half groove, which achieves a concealed joint.

Note: Where fixing half height sheets as a dado wall, provide a row of noggings to allow for fastening of the sheet edge.

When fixing around window openings, best practice would be to align the sheet joints with the window jamb.

## 4.2 FASTENERS

Fasteners must have the appropriate level of durability required for the intended project.

Fasteners must be fully compatible with all other material that they are in contact with to ensure the durability and integrity of the assembly.

- On timber frame use Villadrive screws 30mm x 6g or HardieDrive stainless steel screws for quick installation of HardieGroove sheets.
- Alternatively the HardieGroove sheets can be fixed with 40 x 2.8mm HardieFlex nails or ND 50 brad nails.
- For fixing HardieGroove Lining to 0.55 – 1.0mm BMT steel framing, use 30mm Buildex FibreTEKS collated screws.

Nails must be finished flush (Figure 2). Screws can be driven 0.5mm below the sheet surface to achieve the required finish level (Figure 2). In steel framing the fasteners should be driven as close as possible to the stud corners to avoid deflection of the stud flange, see Figure 3.

Note: Do not place nails or screws within 100mm of the adhesive daubs.

Figure 2: Fastener depth

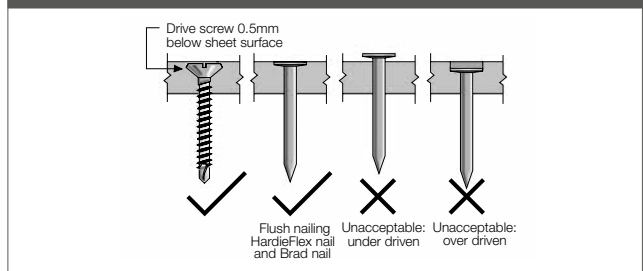
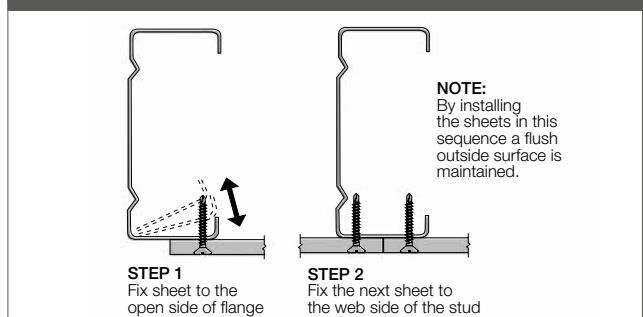

Figure 3: Screw fastening



### 4.3 FIXING TO WALLS

#### Step 1

Place 6.0mm off-cut packers along floor as temporary support for sheets.

This allows provision for frame movement. Put sheet in place as shown.



#### Step 2

Fix sheet starting from the centre of sheet and working outwards to avoid any druminess. For fastener spacings refer to Figures 6 and 8 for full height and dado height walls respectively.



#### Final step

Fix remaining sheets in similar sequence.

### 4.4 FULL SHEET FIXING

When fixing full sheets of HardieGroove Lining to framed walls, fasten sheets as shown in Figure 6. Sheet butt joints must coincide with the centre line of framing members.

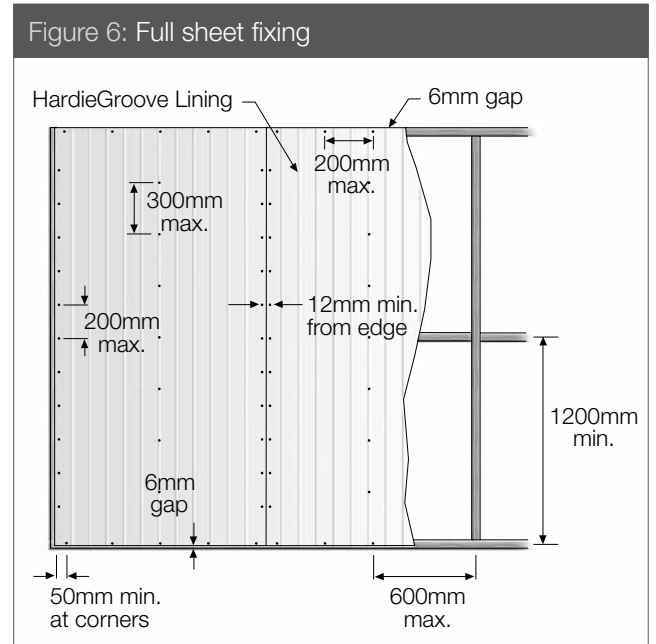

#### NOTES:

1. To reduce the number of visible fixings the centre of the sheet can be fixed with adhesive. See Figure 8 and 9 for details.
2. HardieGroove Lining can also be fixed using brad nails in conjunction with adhesives to reduce visible fixings.

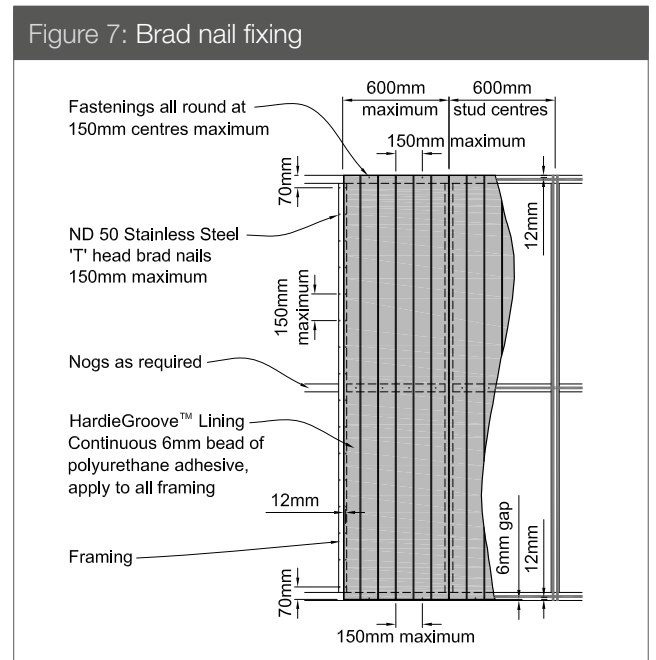

## 4.5 DADO HEIGHT FIXING

HardieGroove Lining may be installed to half the wall height to create a dado appearance. Ensure top of sheet is fixed to an in-line row of noggings as shown in Figure 8 and 9.

Figure 8: Dado height fixing with brads

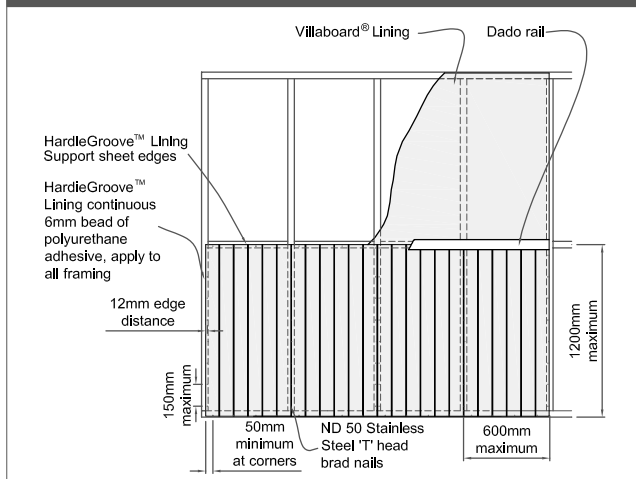
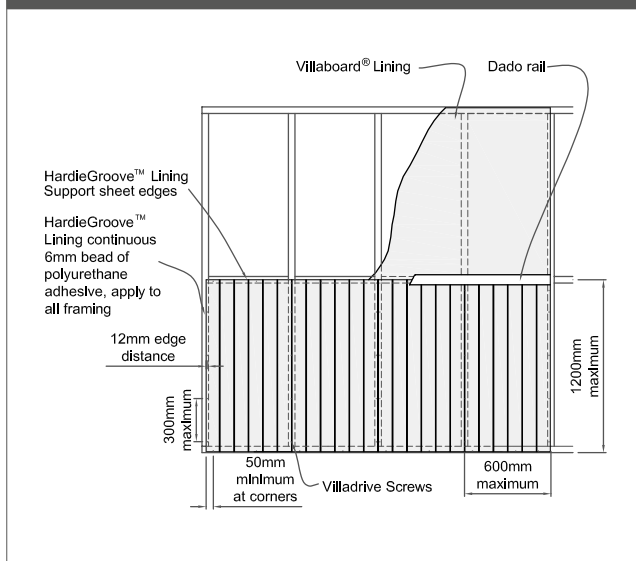

Figure 9: Dado height fixing with screws



## 4.6 FIXING OVER PLASTERBOARD LINING

HardieGroove Lining can be fixed over an existing plasterboard lining. The sheet must be fixed with minimum 50mm nail or a screw 40mm x 8g.

## 4.7 FIXING TO CEILING AND SOFFITS

For Fixing HardieGroove Lining to soffit/ceiling, refer to Eaves and Soffit Linings Installation Manual for further detailed information.

In ceiling applications HardieGroove Lining can be fixed either parallel or perpendicular to framing. See Figure 10.

Figure 10: Along joints

Across joists

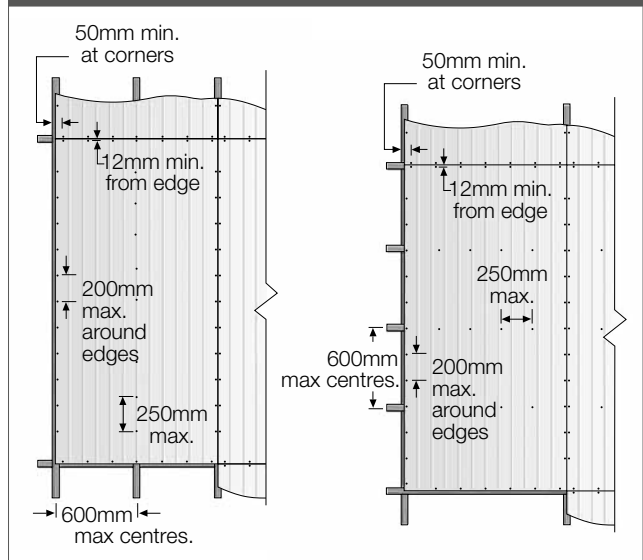

### NOTES:

1. Fastener fixing method is shown, however, fastener/adhesive fixing method may also be used. See Figure 8 and 9.
2. In ceiling applications do not fix sheets to the bottom chord of roof trusses. Instead, fix to timber battens or metal furring channels.
3. Do not use brad nails in ceiling/soffit applications.
4. When butt jointing short ends of HardieGroove Lining in ceiling/soffit applications, the short edges must be cut square and have chamfer formed.

## 4.8 FIXING TO MASONRY SUBSTRATES

HardieGroove Lining can be installed over masonry substrates. Refer Figure 11.

Figure 11: Batten/furring channel

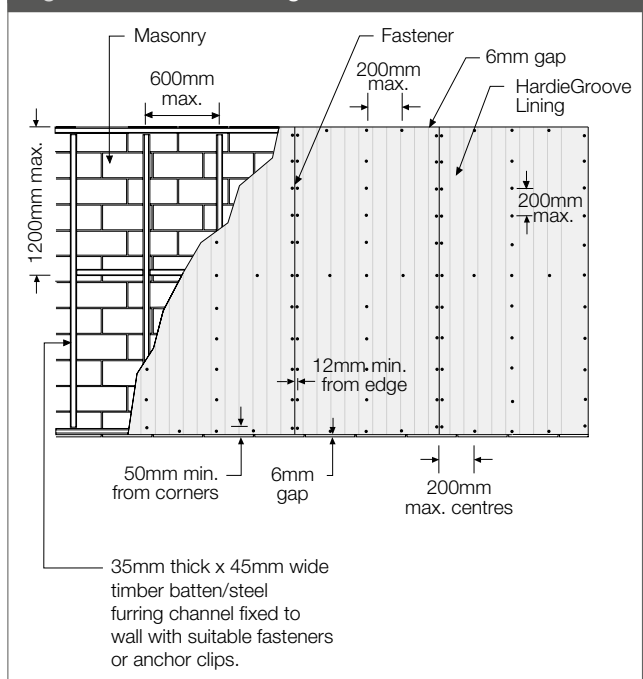



# 5 Jointing and corners

## 5.1 BUTT JOINTS

HardieGroove Lining is butt jointed by joining two factory finished half groove sheet edges on stud. This creates a grooved look consistent with the rest of the sheet. See Figures 12 and 13.

Figure 12: Butt joint

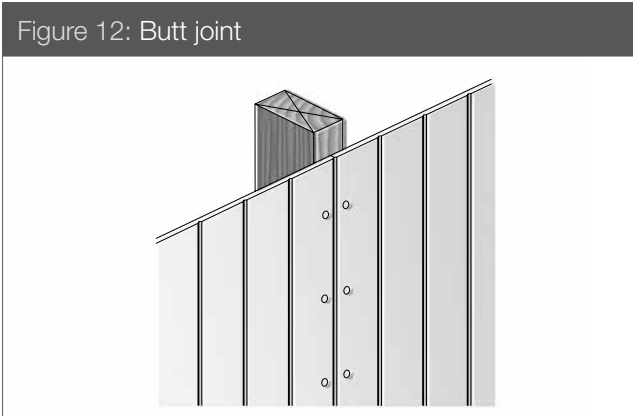
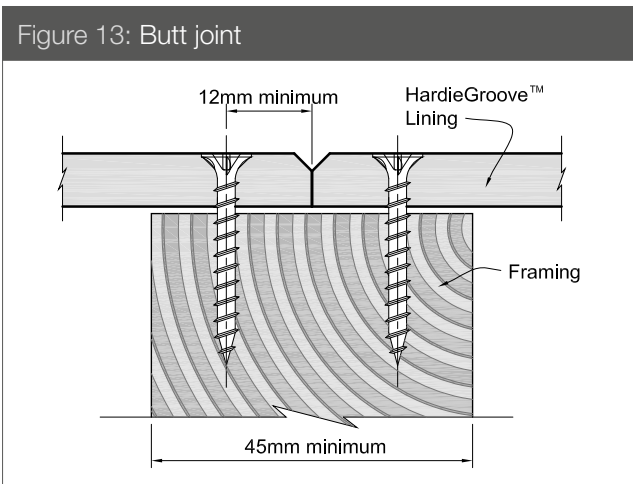

Figure 13: Butt joint



## 5.2 CORNERS

External and internal corners are created by butting sheet edges as shown, see Figures 14 to 16. If sheets need to be trimmed, for best appearance place the cut sheet edge into corner first ensuring that it is hidden by the overlapping sheet. Alternatively a suitable timber moulding may be used.

Figure 14: Corner details

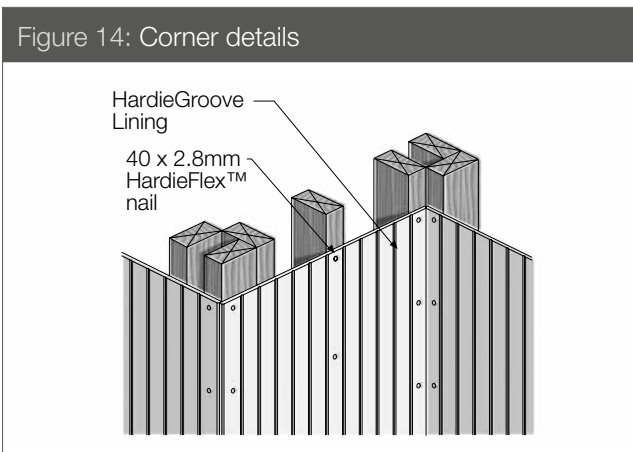

Figure 15: External corner

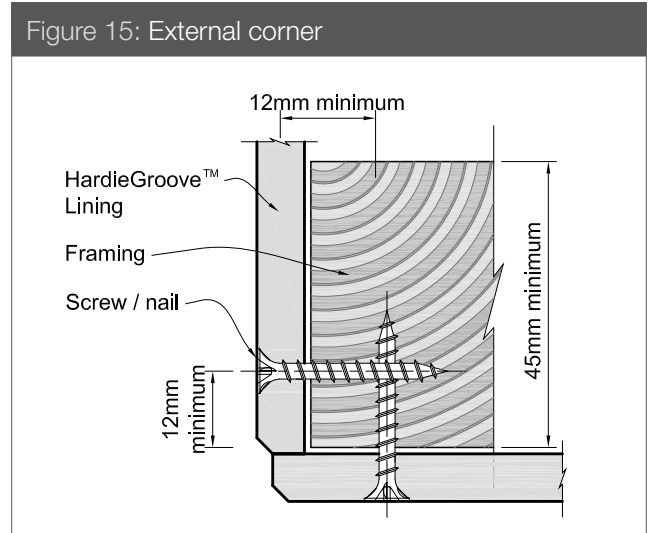
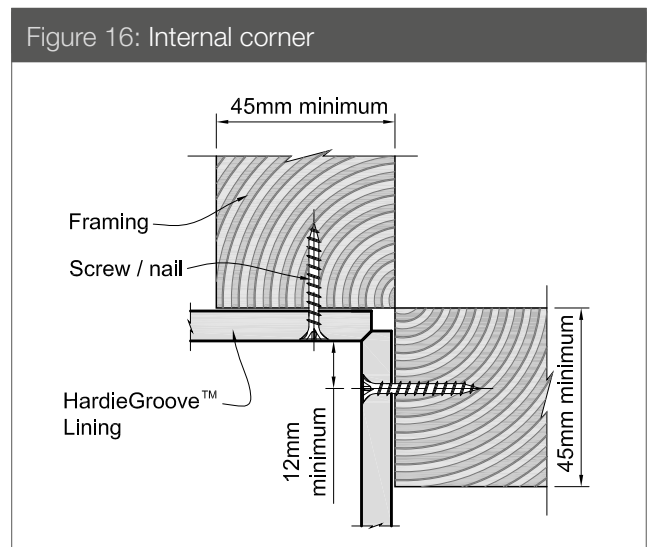

Figure 16: Internal corner



# 6 Product information

## 6.1 GENERAL

---

HardieGroove Lining is a cellulose fibre reinforced cement building product. The basic composition is Portland cement, ground sand, cellulose fibre and water.

HardieGroove Lining is manufactured to AS/NZS 2908.2 'Cellulose-Cement Products Part 2: Flat Sheets' (ISO 8336 'Fibre Cement Flat Sheets').

HardieGroove Lining is classified Type B, Category 3 in accordance with AS/NZS 2908.2 'Cellulose-Cement Products'.

For Material Safety Data Sheets (MSDS) visit [www.jameshardie.co.nz](http://www.jameshardie.co.nz) or Ask James Hardie™ on 0800 808 868.

## 6.2 PRODUCT MASS

---

Based on equilibrium moisture content the approximate mass of HardieGroove Lining is 10.44kg/m<sup>2</sup>.

## 6.3 DURABILITY

---

### Resistance to moisture/rotting

HardieGroove Lining has demonstrated resistance to permanent moisture induced deterioration (rotting) and has passed the following tests in accordance with AS/NZS 2908.2:

- Heat rain (Clause 6.5)
- Water permeability (Clause 8.2.2)
- Warm water (Clause 8.2.4)
- Soak dry (Clause 8.2.5)

## 6.4 FIRE PROPERTIES

---

Maximum service temperature for the HardieGroove Lining is 60°C.

HardieGroove Lining sheet has been tested for heat release rate as per AS/NZS 3837 and the product has a Heat Release Rate below 50 kw/m<sup>2</sup>.

HardieGroove Lining has a 'Group Number' classification of 1-S as per the requirements of clause C of the NZBC.

## 6.5 FINISHES

---

Once HardieGroove Lining has been fixed in place, fill over all fixings with James Hardie Base Coat compound.

Villadrive or HardieDrive screws should be finished 0.5mm below the surface.

When dry, lightly sand smooth and finish with a suitable paint system. Refer to the paint manufacturer for paint suitability, mixing and application.

If staining HardieGroove Lining, care must be taken to ensure the desired finish is achieved. It is advisable to test the stain on an off-cut, paying particular attention to fasteners and filled areas.

## 6.6 MAINTENANCE

---

James Hardie recommends that the cleaning and maintenance of the HardieGroove Lining be undertaken regularly as per the recommendations of the coating manufacturer. Joints must also be maintained and be free of dirt and grime.

James Hardie New Zealand Limited (“James Hardie”) warrants to the first purchaser of the Product for a period of 15 years from the date of purchase that the HardieGroove™ Lining (the “Product”), will be free from defects due to defective factory workmanship or materials and, subject to compliance with the conditions below, will be resistant to cracking, rotting, fire and damage from termite attacks to the extent set out in James Hardie’s relevant published literature current at the time of installation. James Hardie warrants for a period of 15 years from the date of purchase that the accessories supplied by James Hardie to be used in conjunction with the Product will be free from defects due to defective factory workmanship or materials.

Nothing in this document shall exclude or modify any legal rights a customer may have under the Consumer Guarantees Act or otherwise which cannot be excluded or modified at law.

## CONDITIONS OF WARRANTY

The warranty is strictly subject to the following conditions:

- (a) James Hardie will not be liable for breach of warranty unless the claimant provides proof of purchase and makes a written claim either within 30 days after the defect would have become reasonably apparent or, if the defect was reasonably apparent prior to installation, then the claim must be made prior to installation;
- (b) this warranty is not transferable;
- (c) the Product must be installed and maintained strictly in accordance with the relevant James Hardie literature current at the time of installation and must be installed in conjunction with the components or products specified in the literature. To obtain copies of such literature please contact ‘Ask James Hardie™ 0800 808 868’. Further, all other products, including coating and jointing systems, applied to or used in conjunction with the Product must be applied or installed and maintained strictly in accordance with the relevant manufacturer’s instructions and good trade practice;
- (d) the project must be designed and constructed in strict compliance with all relevant provisions of the current NZBC, regulations and standards;
- (e) the claimant’s sole remedy for breach of warranty is (at James Hardie’s option) that James Hardie will either supply replacement product, rectify the affected product or pay for the cost of the replacement or rectification of the affected product;
- (f) James Hardie will not be liable for any losses or damages (whether direct or indirect) including property damage or personal injury, consequential loss, economic loss or loss of profits, arising in contract or negligence or howsoever arising. Without limiting the foregoing James Hardie will not be liable for any claims, damages or defects arising from or in any way attributable to poor workmanship, poor design or detailing, settlement or structural movement and/or movement of materials to which the Product is attached, incorrect design of the structure, acts of God including but not limited to earthquakes, cyclones, floods or other severe weather conditions or unusual climatic conditions, efflorescence or performance of paint/coatings applied to the Product, normal wear and tear, growth of mould, mildew, fungi, bacteria, or any organism on any Product surface or Product (whether on the exposed or unexposed surfaces);
- (g) all warranties, conditions, liabilities and obligations other than those specified in this warranty are excluded to the fullest extent allowed by law;
- (h) if meeting a claim under this warranty involves re-coating of Products, there may be slight colour differences between the original and replacement Products due to the effects of weathering and variations in materials over time.

DISCLAIMER: The recommendations in James Hardie’s literature are based on good building practice, but are not an exhaustive statement of all relevant information and are subject to conditions (c), (d), (f) and (g) above. James Hardie has tested the performance of HardieGroove™ Lining when installed in accordance with the HardieGroove™ Lining installation manual, in accordance with the standards and verification methods required by the NZBC and those test results demonstrate the product complies with the performance criteria established by the NZBC. However, as the successful performance of the relevant system depends on numerous factors outside the control of James Hardie (e.g. quality of workmanship and design) James Hardie shall not be liable for the recommendations made in its literature and the performance of the relevant system, including its suitability for any purpose or ability to satisfy the relevant provisions of the NZBC, regulations and standards, as it is the responsibility of the building designer to ensure that the details and recommendations provided in the relevant James Hardie installation manual are suitable for the intended project and that specific design is conducted where appropriate.

Copyright April 2019. © James Hardie New Zealand Limited. TM and ® denotes a Trademark or Registered Mark owned by James Hardie Technology Limited.

