



# CLD Structural Cavity Batten Technical Specification

# Content

|          |  |          |           |                                  |           |
|----------|--|----------|-----------|----------------------------------|-----------|
| <b>1</b> | <b>APPLICATION AND SCOPE</b>           | <b>3</b> | <b>5</b>  | <b>BATTEN INSTALLATION</b>       | <b>6</b>  |
| 1.1      | Application                            | 3        | 5.1       | CLD™ Structural Cavity Batten    | 6         |
| 1.2      | Scope                                  | 3        | 5.2       | Batten Layout                    | 6         |
| 1.3      | Details                                | 3        | 5.3       | Intermediate Support             | 6         |
|          |  |          | 5.4       | Batten Fasteners                 | 6         |
| <b>2</b> | <b>DESIGN</b>                          | <b>3</b> | <b>6</b>  | <b>PANEL INSTALLATION</b>        | <b>7</b>  |
| 2.1      | Specific Design                        | 3        | 6.1       | General                          | 7         |
| 2.2      | Compliance                             | 3        | 6.2       | Titan™ Façade Panel Installation | 7         |
| 2.3      | Responsibility                         | 3        | 6.3       | Fastener Durability              | 8         |
| 2.4      | Site and Foundation                    | 3        | 6.4       | Adhesive Sealant                 | 8         |
| 2.5      | Surface Clearances                     | 4        |           |                                  |           |
| 2.6      | Moisture Management                    | 4        | <b>7</b>  | <b>JOINTS</b>                    | <b>8</b>  |
| 2.7      | Structure                              | 4        | 7.1       | Vertical Joint                   | 8         |
| 2.8      | Seismic Deflections                    | 4        | 7.2       | Horizontal Joint                 | 8         |
| 2.9      | Structural Bracing                     | 4        | 7.3       | Horizontal Drainage Joint        | 8         |
| 2.10     | Fire Rated Walls                       | 4        | 7.4       | External and Internal Corners    | 8         |
| 2.11     | Energy Efficiency                      | 4        |           |                                  |           |
| <b>3</b> | <b>FRAMING</b>                         | <b>5</b> | <b>8</b>  | <b>FINISHING</b>                 | <b>9</b>  |
| 3.1      | General                                | 5        | 8.1       | Painting                         | 9         |
| 3.2      | Timber Framing                         | 5        | 8.2       | Flexible Sealant                 | 9         |
| 3.4      | Tolerances                             | 5        | 8.3       | Epoxy Fillers                    | 9         |
| <b>4</b> | <b>PREPARATION</b>                     | <b>5</b> | <b>9</b>  | <b>STORAGE AND HANDLING</b>      | <b>10</b> |
| 4.1      | Flexible Underlay/HomeRAB Pre-Cladding | 5        | <b>10</b> | <b>MAINTENANCE</b>               | <b>10</b> |
| 4.2      | RAB™ Board                             | 5        | <b>11</b> | <b>PRODUCT INFORMATION</b>       | <b>10</b> |
| 4.3      | Vent Strip                             | 6        | 11.1      | Material                         | 10        |
| 4.4      | Flashing                               | 6        | 11.2      | Durability                       | 10        |
| 4.5      | Junctions and Penetrations             | 6        |           |                                  |           |
|          |  |          | <b>12</b> | <b>SAFE WORKING PRACTICES</b>    | <b>11</b> |
|          |  |          | <b>13</b> | <b>PRODUCT AND ACCESSORIES</b>   | <b>12</b> |
|          |  |          | <b>14</b> | <b>DETAILS</b>                   | <b>14</b> |
|          |  |          |           | <b>PRODUCT WARRANTY</b>          | <b>35</b> |

## WE VALUE YOUR FEEDBACK

To continue with the development of our products and systems, we value your input. Please send any suggestions, including your name, contact details, and relevant sketches to:

Ask James Hardie™

[literaturefeedback@jameshardie.co.nz](mailto:literaturefeedback@jameshardie.co.nz)

**THIS TECHNICAL SPECIFICATION IS FOR TITAN™ FAÇADE  
PANEL FIXED TO CLD™ STRUCTURAL CAVITY BATTEN.**

# 1 Application and scope

## 1.1 APPLICATION

---

The Titan™ Façade Panel installed as per this specification provides a durable, expressed joint panel appearance for residential/commercial building façades. Titan Façade Panel cladding can be fixed over timber frame or lightweight construction steel-framed walls. A wide range of colours can be used over Titan Façade Panels.

### Specifier

If you are a specifier or other responsible party for a project ensure that the information in this document is appropriate for the application you are planning and that you undertake specific design and detailing for areas which fall outside the scope of these specifications.

### Installer

If you are an installer ensure that you follow the design, moisture management principles, associated details and material selection provided by the designer. All the details provided in this document must be read in conjunction with the specifier's specification.

### Make sure your information is up to date

When specifying or installing James Hardie products, ensure you have the current manual. If you're not sure you do, or you need more information, visit [www.jameshardie.co.nz](http://www.jameshardie.co.nz) or Ask James Hardie™ on 0800 808 868.

## 1.2 SCOPE

---

This specification covers the use of Titan Façade Panel on buildings, where the maximum wind pressure exerted on the building façade is up to 2.5kPa (ULS).

This specification is intended for use by architects or designers/specifier and installers who may be involved with the specification of Titan Façade Panel, CLD™ Structural Cavity Battens and their installation. The specification must be read in conjunction with the figures provided at the rear of this document and project specific drawing/specifications.

### NOTE:

For installing Titan Façade Panel using timber cavity battens, refer to Titan Façade Panel/ExoTec Façade Panel Rainscreen technical specification available for download at [www.jameshardie.co.nz](http://www.jameshardie.co.nz)

## 1.3 DETAILS

---

Various typical Titan Façade Panel construction details are provided in the Details section of this document. All dimensions shown are in millimetres unless noted otherwise. These details are also available in CAD file format and can be downloaded from our website at [www.jameshardie.co.nz](http://www.jameshardie.co.nz).

# 2 Design

## 2.1 SPECIFIC DESIGN

---

For the use of Titan Façade Panel and CLD Structural Cavity battens outside the scope of this specification, the designer, architect or engineer must ensure that the relevant clauses of the New Zealand Building Code (NZBC) have been considered and the intent of their design meets the requirements of the NZBC. Project specific details are required to be developed if they are not covered in this literature.

## 2.2 COMPLIANCE

---

Titan Façade Panel and CLD Structural Cavity Battens installed as per this technical specification have been tested in a NATA accredited testing laboratory and complies with the requirements of Structure B1, Durability B2 and External Moisture E2 Clauses of the NZBC.

## 2.3 RESPONSIBILITY

---

The specifier or the other party responsible for the project is responsible for ensuring that the information and details included in this technical specification are suitable for the intended application.

The specifier shall accommodate the appropriate provisions required by the NZBC. Careful detailing of all penetrations through the flexible underlay/rigid air barrier is required and must be appropriately flashed and weatherproofed. The other materials and components that are used to manage moisture must be installed as per their manufacturers' instructions and comply with the requirements of the relevant standards and the NZBC.

The designer/specifier must ensure that all the reference documents and standards referred to in this document or during the design and construction process are current editions and are complied with. The designer must identify the moisture related risks associated with the particular building design. The design and construction must effectively manage the external moisture.

For the latest information in relation to designing for weathertightness refer to [www.branz.co.nz](http://www.branz.co.nz) and [www.building.govt.nz](http://www.building.govt.nz) websites.

James Hardie conducts stringent quality checks to ensure that any product manufactured falls within our quality spectrum. It is the responsibility of the builder to ensure that the product meets aesthetic requirements before installation. James Hardie will not be responsible for rectifying obvious aesthetic surface variations following installation.

## 2.4 SITE AND FOUNDATION

---

The site on which the building is situated must comply with E1 'Surface Water' Clause of the NZBC. The grade of adjacent finished ground must slope away from the building to avoid any possibility of water accumulation as per the NZBC requirements.

For SED 'Specific Engineering Design' projects the foundation must be designed and certified by a qualified structural engineer and comply with all relevant codes, regulations and standards.

## 2.5 SURFACE CLEARANCES

---

The clearance between the bottom edge of cladding and paved/unpaved ground must comply with section 9.1.3 of 'E2 /AS1'. The finished floor level must also comply with these requirements. These clearances must be maintained throughout the life of the building.

Titan Façade Panels must overhang the bottom plate on a concrete slab by a minimum of 50mm.

Titan Façade Panel must always maintain a clearance of 100mm from paved grounds and 175mm from unpaved grounds. On roofs and decks etc. a minimum clearance of 50mm must be maintained.

Do not install Titan Façade Panels such that it may remain in contact with standing water.

## 2.6 MOISTURE MANAGEMENT

---

It is the responsibility of the specifier to identify moisture related risks associated with any particular building design. Wall construction design must effectively manage moisture, considering both the interior and exterior environment of buildings, particularly in buildings that have a higher risk of wind driven rain penetration or that are artificially heated or cooled. Walls must include those provisions as required by the NZBC Acceptable Solution 'E2/AS1-External Moisture'. In addition, all wall openings, penetrations, junctions, connections, windowsills, heads and jambs must incorporate appropriate flashings for waterproofing. The other materials, components and installation methods used to manage moisture in external walls, must comply with requirements of NZBC and any other regulations or standards applicable. For further guidance on designing for weathertightness refer to BRANZ Ltd and the Ministry of Business Innovation and Employment (MBIE) updates on the following websites respectively, [www.branz.co.nz](http://www.branz.co.nz) and [www.building.govt.nz](http://www.building.govt.nz).

In addition, the following points must be considered:

- Flexible sealant in vertical panel joints must be applied as detailed in this technical specification
- For projects within the scope of E2/AS1 where the walls are higher than two storeys, it is necessary to provide a horizontal flashing joint after two floors to drain the cavity
- The installation of smoke chimneys, pipe penetrations and other fixtures etc. must not restrict the free flow of moisture to the exterior

## 2.7 STRUCTURE

---

### 2.7.1 Timber Framing

For residential buildings the timber framing must be provided in accordance with NZS 3604 (Timber-framed Buildings). When the framing is provided as per the specific engineering design, the framing stiffness must be equivalent to, or more than the minimum stiffness requirements of NZS 3604.

For specific engineering frame design, refer to NZS 3603 and AS/NZS 1170 for framing design.

For timber frame walls longer than 12m, it is best practice to allow for construction joints to accommodate movements generated due to timber shrinkage or deflection etc.

### 2.7.2 Steel Framing

Steel-framed buildings are outside the scope of this specification. Refer to James Hardie for information on steel frame construction.

### 2.7.3 Wind Loading

Titan Façade Panel cladding installed as per this technical specification is suitable for use up to maximum wind pressures of 2.5kPa (ULS).

## 2.8 SEISMIC DEFLECTIONS

---

Titan Façade Panel installed in accordance with this technical specification is capable of withstanding deflections of the support structure (for example seismic drift) up to a magnitude of span/250 or maximum of 15mm, as determined at the Serviceability Limit State (SLS).

## 2.9 STRUCTURAL BRACING

---

Titan Façade Panels installed as per this specification have not been tested and therefore cannot be used to achieve structural bracing. However, bracing can be achieved by using RAB™ Board fixed direct to the framing or by using internal linings such as Villaboard™ Lining or plasterboard.

## 2.10 FIRE RATED WALLS

---

A fire rating of up to 60 minutes can be achieved when using a RAB Board in lieu of a flexible underlay and installing Titan Façade Panels as per this specification. Ask James Hardie on 0800 808 868 for further information.

## 2.11 ENERGY EFFICIENCY

---

External walls constructed using James Hardie Titan Façade Panel and bulk insulation, where the area of glazing is 30% or less of the total wall area, complies with the requirements for walls in the NZBC Acceptable Solution H1/AS1 (NZBC Clause H1 Energy Efficiency), Table 1.

To meet thermal insulation requirements for the construction, the bulk insulation as specified in Table 1 must be used. This insulation may be substituted with insulations having higher R-values. The thermal insulation of a wall gets affected when the depth of the timber framing is increased or decreased. The calculation used in Table 1 is based on a timber framing size 90 x 45mm and using an internal lining material such as Villaboard Lining or a 10mm plasterboard.

Table 1

| Insulation capability |                                  |  |
|-----------------------|----------------------------------|--|
| Climate zone          | Construction R-value requirement | Minimum R-value of insulation required |
| 1 and 2               | 1.9 m <sup>2</sup> °C/W          | R2.0 <sup>#</sup>                      |
| 3                     | 2.0 m <sup>2</sup> °C/W          | R2.2 <sup>#</sup>                      |

Total construction R-value depends on the insulation material used and the framing ratio. The insulation material R-values specified in this table are for studs spaced at 600mm centres and nogs spaced at 800mm centres.

\* To achieve higher R-values of construction the wall insulation must be replaced with an insulation material having higher R-values to suit the requirements.

For further guidance on insulation requirement refer to the current edition of 'House Insulation Guide' published by BRANZ.

## 3 Framing

### 3.1 GENERAL

Titan Façade Panels can be installed to timber-framed or steel-framed structures. Fixing to any other framing material is subject to a specific engineering design.

- Stud spacing must not exceed 600mm centres
- Nog/dwang spacing must not exceed 800mm centres when studs are at 600mm centres

NOTE: Titan Façade Panel fastener spacings are provided in Table 3 Section 6.

### 3.2 TIMBER FRAMING

#### 3.2.1 Dimensions

A minimum 45mm stud width is required.

#### 3.2.2 Structural Grade

Minimum structural grade of timber framing to be used must be in accordance with those specified in NZS 3604.

#### 3.2.3 Durability

The external framing must be treated to minimum H1.2 treatment. Higher treatment levels may be used but check for the compatibility of treatment chemicals with other materials. Refer to The NZBC Acceptable Solution B2/AS1 'Durability' for further information about the durability requirements.

For timber treatment and allowable moisture content information refer to NZS 3602 (Timber and Wood-Based Products for use in Buildings) and NZS 3640 (Chemical Preservation of Round Sawn Timber) for minimum timber treatment selection and treatment requirements. Also refer to framing manufacturer's literature for further guidance on timber selection. Framing must be protected from moisture on site in accordance with the recommendations of the framing manufacturers.

NOTE: Refer to NZS 3602 for information about the allowable moisture content in timber framing.

### 3.2.4 Frame Construction

The framing must be rigid and not rely on the cladding panel for stability.

All timber framing sizes and set out must comply with NZS 3604 or specific engineering design requirements and as specified in this specification.

In case of gable end trusses sitting on top plates of the external wall frame, the frame size must be in accordance with truss design and specification supplied by the frame and truss manufacturer/supplier supported by an independent design producer statement.

Note: It is recommended that the CLD Structural Cavity Battens be installed prior to plumbing, electrical and other services within the frame. This will prevent these services from being damaged by fasteners used to install the battens.

### 3.3 TOLERANCES

In order to achieve the required performance and an acceptable wall finish, it is imperative that framing is straight and true. Framing tolerances must comply with the relevant codes, manufacturer's specifications and design requirements. All framing shall be made flush.

## 4 Preparation

### 4.1 FLEXIBLE UNDERLAY/HOMERAB PRE-CLADDING

Flexible underlay or HomeRAB™ Pre-Cladding must be provided as per the requirements of the NZBC Acceptable Solution E2/AS1 'External Moisture' and NZS 3604. The flexible underlay must comply with Table 23 of E2/AS1 and AS/NZS 4200.1. The flexible underlay must be fixed in accordance with E2/AS1, NZS 3604 and AS/NZS 4200.2 'Pliable Building Membranes and Underlay – Installation' standard and the underlay manufacturer's recommendations.

Walls which are not lined on the inside face (e.g. garage walls or gable ends) must include a rigid sheathing or an air barrier behind the cladding which complies with the requirements of the NZBC Acceptable Solution E2/AS1 Table 23. For attached garages, wall underlays must be selected in accordance with the NZBC Acceptable Solution E2/AS1, Paragraph 9.1.3.4. HomeRAB Pre-Cladding is suitable for use in these applications. It must be installed in accordance with the James Hardie Rigid Air Barriers installation manual.

### 4.2 RAB BOARD

General flexible underlay or HomeRAB Pre-Cladding is suitable for use up to very high wind speed zone (50m/sec).

When an EH wind zone or for specific design projects where the wind pressure is higher than 1.5kPa, RAB Board must be used instead of flexible underlay.

To achieve the temporary weathertightness using James Hardie

# 5 Batten installation

rigid air barriers, windows/doors need to be temporarily installed. Refer to James Hardie Rigid Air Barriers installation manual for information regarding its installation.

## 4.3 VENT STRIP

The James Hardie uPVC cavity vent strip must be installed at the bottom of all walls constructed using the drained and ventilated cavity construction method. It is important that the openings in the vent strip are kept clear of obstructions to allow free drainage and ventilation of cavities. James Hardie uPVC vent strip has an opening area of 1000mm<sup>2</sup>/m length, refer to Figure 4.

## 4.4 FLASHING

All wall openings, penetrations, intersections, connections, window sills, heads and jambs must be flashed prior to panel installation. Please refer to moisture management requirements in Clause 2.6. The flexible underlay or James Hardie rigid air barrier must be appropriately taped around the penetrations and lapped/taped to flashings. Materials must be lapped in such a way that water tracks down to the exterior of a building. The selected flashing materials must comply with the durability requirements of the NZBC. For information refer to Table 20 of clause E2 of the NZBC.

When using James Hardie rigid air barriers, the entire framing around window opening must be protected with a flashing tape. The tape must be finished over the face of James Hardie rigid air barriers. The flashing tapes like SUPER-STICK Building Tape® by Marshall Innovation or 3M™ All Weather Flashing Tape 8067 by 3M™ are recommended for use with James Hardie rigid air barriers. Refer to tape manufacturer's literature for further information regarding their installation.

## 4.5 JUNCTIONS AND PENETRATIONS

Refer to Clause 2.6 of this specification for moisture management requirements. All windows and doors must be detailed as per the requirements of this specification. James Hardie has developed the window details for Titan Façade Panel which meet the performance requirements of E2 'External Moisture', an approved document of the NZBC, refer to Figures 17 to 19.

## 5.1 CLD STRUCTURAL CAVITY BATTEN

The CLD Structural Cavity Batten is suitable to have Titan Façade Panel fixed into them. The battens are 2450mm long, 70mm wide and 19mm thick. The battens are fully sealed on all faces. Refer to Section 14 Details for information about installation.

NOTE: For installing Titan Façade Panel using timber cavity battens, refer to Titan Façade Panel/ExoTec Façade Panel Rainscreen technical specification available for download at [www.jameshardie.co.nz](http://www.jameshardie.co.nz)

## 5.2 BATTEN LAYOUT

CLD Structural Cavity Battens must be fixed to the wall framing over building underlay or James Hardie rigid air barriers. The smoother face of batten should face towards the cladding.

CLD Structural Cavity Battens are suitable to withstand wind pressures up to 2.5kPa (ULS). For batten fixing, refer to clause 5.4. Ensure the battens are straight and provide a flat surface to fix Titan Façade Panel to. Site cut ends of battens must be sealed on site with Dulux® Acraprime 501/1 sealer or Resene Quick Dry.

The battens are run continuously over the studs but they must not be run continuously over the floor joists. There must be a 15mm gap between the battens at floor joist level to allow for structural shrinkages and deflections. Refer to Figure 22.

CLD Structural Cavity Battens can be butt jointed over the studs within the floor height. The batten ends must be cut between 20° to 45° and be installed in a way that the butt joint deflects the moisture to the exterior. The ends must be sealed and jointed with the adhesive sealant before butting them together. Refer to Figure 16.

The designer must ensure that the CLD Structural Cavity Battens are not used in situations where design wind pressures are above 2.5kPa (ULS).

CLD Structural Cavity Battens must not be used to a length smaller than 300mm.

At corners install over polypropylene tape refer to Figures 13 and 14.

## 5.3 INTERMEDIATE SUPPORT

A nylon strap or galvanised wire must be at 300mm centres fixed horizontally and drawn taut to restrain the insulation from bulging into the cavity, where the studs are spaced at 600mm centres. When RAB Board is used or the studs are spaced at maximum 400mm centres, no intermediate support is required.

## 5.4 BATTEN FASTENERS

The CLD Structural Cavity Batten must be fixed to the framing as specified in Table 2. The fasteners must be driven at a minimum distance of 50mm from the batten ends.

Table 2

| Batten fixing  |                          |  |                          |                           |
|--|--------------------------|--|--------------------------|---------------------------|
| Fixing type  | Framing                  | Design wind pressure kPa (ULS)               | Batten centres max. (mm) | Fixings centres max. (mm) |
| 65mm x 2.8mm RounDrive ring shank nail hot dip galv./s.steel | Timber                   | Up to 1.5 (up to and including VH wind zone) | 600                      | 250                       |
|  |                          | Up to 2.5 (>VH wind zone)                    | 400                      | 200                       |
| 50mm x 9-10g Countersunk head steel screw class 3/4          | Steel 0.55 to 1.6mm BMT* | Up to 1.5 (up to and including VH wind zone) | 600                      | 250                       |
|  |                          | Up to 2.5 (> VH wind zone)                   | 400                      | 200                       |

\*When fixing CLD Structural Cavity Batten over steel frame, provide a 10mm thick HDP batten under the underlay or RAB Board to achieve thermal break. Ensure a minimum 15mm penetration of screw into steel frame. Refer to James Hardie steel framing supplement for further information.

For fastener durability information, refer to Clause 6.3 of this document.

CLD Structural Cavity Battens less than 400mm in length must have fixings at maximum 150mm centres.

## 6 Panel installation

### 6.1 GENERAL

Titan Façade Panel and CLD Structural Cavity Battens must be kept under cover whilst in storage or at sites and they must be dry at the time of their installation. All site cut panel edges must be sealed with Dulux AcraPrime 501/1, Resene® Quick Dry or similar sealer compatible with the finish coat before installation. It is recommended to fix from the centre of the panel and work outwards. The straightness of timber framing is essential to achieve the flatness on panel surface. Ensure that panels are hard against the battens to avoid drumminess.

When Titan Façade Panel is to be cut in sizes smaller than 1200 x 1190mm, or where the Titan Façade Panel is cut to narrower widths eg 600mm or 400mm and fixed horizontally, the CLD Structural Cavity Batten must be installed at 400mm maximum centres.

Apply a continuous 6mm thick bead of Bostik® Seal N Flex®-1 or Sika® Sikaflex-11FC adhesive sealant to the face of CLD

Structural Cavity Batten to adhere the Titan Façade Panel to it. Titan Façade Panel must be pushed hard against the CLD Structural Cavity Batten when fixing.

Always consider panel layout carefully to minimise site wastage. It is best practise to panelise around the window/door openings by aligning the negative joint with jambs or window/door heads/sills, refer to Figure 3.

### 6.2 TITAN FAÇADE PANEL INSTALLATION

The Titan Façade Panels are fixed to CLD Structural Cavity Battens using one of the following fixings specified in Table 3:

Table 3

| Titan Façade Panel fixing                                  |   |  |
|--|---|--|
| Types of fixings to be used with adhesive sealants         | Suitable up to design wind pressure kPa (ULS) | Fixing to CLD Structural Cavity Battens centres (mm) |
| C-25 'T'- Head stainless steel brad nail                   | 1.5 (Up to and including VH wind zone)        | 150  |
| 25 x 2.5mm annular threaded fibre cement nail              | 2.5 (> VH wind zone)                          | 200  |
| 25mm x 10g counter sunk screw class 3/4 or stainless steel | 2.5 (> VH wind zone)                          | 200  |
| 25mm x 8-15g OR Pan/Wafer head exposed screw class 3/4     | 2.5 (> VH wind zone)                          | 200  |

#### 6.2.1 T-Head Brad Nails

A combination of stainless steel straight T-head brad nail and Bostik Seal N Flex -1 or Sika 'Sikaflex-11FC' adhesive sealant provides a fast and efficient method of panel installation. It also minimises the preparation required before painting the panels. T-head brad nails are fired using the brad nail guns and nail heads finished flush with panel surface.

This fixing method is only suitable for projects within the scope of NZS 3604 or up to 1.5kPa design wind pressures.

Apply a 6mm thick continuous bead of Bostik Seal N Flex-1 or Sika 'Sikaflex-11FC' adhesive sealant to the face of CLD Structural Cavity Batten first then fix the panel with T-head brad nails securing the panel in place while the adhesive cures. A good practice is to set the brad nail gun to fire nails 2-3mm proud of the panel surface keeping a consistent pressure on the panel while fixing. Let the adhesive go off for approximately 1-2 hours whilst continuing work on the next section. Come back later and hammer the nails flush with panel surface. Use Paslode® C-25 304 stainless steel brad nails.

The edge distance required for fixing T-head brad nails is 12mm, refer to Figure 6.

NOTE: Do not use this fixing method in specific engineering design (SED) wind zones.

### 6.2.2 Fibre Cement Nails

Titan Façade Panel can be installed using a 25mm x 2.5mm annular threaded fibre cement nail. These nails must be driven flush with the panel surface. Apply a 6mm thick continuous bead of Bostik Seal N Flex-1 or Sika Sikaflex-11FC adhesive sealant over the CLD Structural Cavity Batten before fixing Titan Façade Panels, refer to section 6.3 for the durability requirements.

Always ensure that the fibre cement nails are finished flush prior to finishing, refer to section 8.

The edge distance required for fixing fibre cement nails is 12mm, refer to Figure 7.

### 6.2.3 Countersunk Screws

Titan Façade Panels must be pre-drilled on the ground before installation using a JH counter sunk drill bit. A 25mm x 10g countersunk screw is suitable for this installation method. The screw head must be countersunk to a depth of 2mm maximum below the Titan Façade Panel surface. Apply a 6mm thick continuous bead of Bostik Seal N Flex-1 or Sika Sikaflex-11FC adhesive sealant over the CLD Structural Cavity Batten before fixing the Titan Façade Panels.

The typical edge distance required for screw fixing is 18mm, refer to Figure 9.

The torque setting of the drill used to fix screws must be set to a low torque level to ensure the screw is not over driven into the CLD Structural Cavity Batten. The screws must be manually tightened prior to epoxy filling.

The counter sunk screw holes are flush finished with two part epoxy filler. Allow epoxy to cure, sand the epoxy to a smooth finish with 60-80 grit sandpaper then prime over. Ensure the epoxy manufacturer's recommendations are followed.

### 6.2.4 Exposed Head Screws

Exposed head screws, e.g. pan, wafer and hex head fasteners may be colour coated to match the panel finish. Use a 25mm x 8-15g screw.

Titan Façade Panels must be pre-drilled with a masonry drill bit. Apply a 6mm thick continuous bead of Bostik Seal N Flex-1 or Sika Sikaflex-11FC adhesive sealant over the CLD Structural Cavity Batten before fixing the Titan Façade Panel over it. Titan Façade Panel must be pushed hard against the CLD Structural Cavity Batten when fixing.

The edge distance required for fixing screws is 18mm.

A nylon washer must be used under the exposed screw heads for sealing against the Titan Façade Panel surface, refer to Figure 11.

## 6.3 FASTENER DURABILITY

Fasteners must comply with the minimum durability requirements of the NZBC. The NZS 3604 specifies the requirements for fixing materials to be used in relation to exposure zones and are summarised in Table 4.

Fasteners must be fully compatible with other materials they are to be in contact with, to ensure the durability of complete assembly.

For steel framing ensure that the fasteners used are compatible with steel framing.

Contact fastener manufacturers for more information.

Table 4

| Exposure conditions and nail selection prescribed by NZS 3604 |             |                            |
|---|-------------|----------------------------|
| Zone  | Application | Nail material              |
| D<br>(Sea Spray)*   | General     | Stainless steel<br>304/316 |
|   | Fire        |                            |
|   | Bracing     |                            |
| C and B and<br>Geothermal<br>hot spots                        | General     | Hot Dip<br>Galvanised**    |
|   | Fire        |                            |
|   | Bracing     |                            |

\*(Zone C areas where local knowledge dictates that increased durability is required, appropriate selection shall be made)

Microclimate conditions as detailed in NZS 3604, paragraph 4.2.4 require SED.

Also refer to the NZBC Acceptable Solution 'E2/AS1' Table 20 and 22 for information regarding the selection of suitable fixing materials and their compatibility with other materials.

\*\*When using brad nails for panel fixing, they must be stainless steel regardless of the exposure zone.

## 6.4 ADHESIVE SEALANT

A polyurethane adhesive sealant Seal 'N' Flex-1 manufactured by Bostik or Sikaflex-11FC by Sika have been tested and must be used as per this specification. Apply a 6mm continuous bead of this adhesive sealant over the face of CLD Structural Cavity Batten before fixing the Titan Façade Panel.

NOTE:

Do not use excessive adhesive sealant.



# 7 Joints

Titan Façade Panels are fixed keeping a 10mm nominal gap between panels at vertical and horizontal joints.

## 7.1 VERTICAL JOINT

CLD Structural Cavity Batten is fixed over the studs and a vertical joint is formed over the batten. A 10mm gap is required between the panels to form a vertical expressed joint. After the installation of panels to CLD Structural Cavity Battens, the joints must be sealed with a flexible sealant. Refer to Figures 6, 8, 10 and 12.

When Titan Façade Panel is laid horizontally, ensure correct length of panel so vertical joint is centred over the CLD Structural Cavity Batten.

## 7.2 HORIZONTAL JOINT

Aluminium 'T' socket or a Z flashing is used to form a horizontal joint between the panels.

When using a 'T' socket, it is cut to suit the exact width of each panel. Two 6mm thick continuous beads of adhesive sealant are run over the bottom (short) portion of 'T' socket and the socket is glued to the lower panel, refer to Figure 21. The 'T' lip sits over the top edge of lower Titan Façade Panel.

When a horizontal joint using a 'T' socket is formed at the floor joist level, a cavity batten flashing is required at the CLD Structural Cavity Batten joint, refer to Figure 22.

At internal and external corners a CLD Structural Cavity Batten corner flashing is used, refer to Figure 23.

At every floor a horizontal joint flashing is required.

## 7.3 HORIZONTAL DRAINAGE JOINT

The wall cavities must be drained every two floors to facilitate moisture drainage and ventilation, refer to Figure 24.

## 7.4 EXTERNAL AND INTERNAL CORNERS

Two CLD Structural Cavity Battens are fixed in the corners to facilitate the fixing of Titan Façade Panel to battens on each side. Ensure 200mm minimum wide polypropylene or flashing tape is applied to building paper over timber framing prior to CLD Structural Cavity Battens installation. Refer to Figures 13 and 14.

A 10mm gap is required between the Titan Façade Panels to form a vertical expressed joint at corners. Ensure the correct batten panel orientation for panel installation and a continuous bead of adhesive sealant is applied between CLD Structural Cavity Battens. Refer to Figures 13 and 14.

Alternatively, an aluminium box corner can be used, refer to Figure 15.

# 8 Finishing

## 8.1 PAINTING

Painting of Titan Façade Panel is mandatory to meet the durability requirements of the NZBC and the 15 year James Hardie product warranty. Titan Façade Panels must be dry and free of any dust or grime before painting. The panels must be painted within 90 days of their installation. There is no restriction on the LRV of paint to be applied on the Titan Façade Panel.

Titan Façade Panels are pre-primed and are suitable for site applied acrylic paints. Pre-finished panels can also be installed using exposed head fasteners.

In order to seal cut edges or sanded patches, Dulux® AcraPrime 501/1 acrylic primer, Dulux 1 Step, Watty® Granoprime or a similar product should be applied. The primer should be compatible with the paint to be used.

Where panels are fixed with brad nails, the nail heads must be finished flush with panel surface. The nail heads can be skimmed over with an exterior grade 2 part builders fill, if required. The skimmed area must be primed prior to site-applied finishing.

For site-applied finishes where brad nails or exposed head screws are used, James Hardie recommends a minimum of two coats of high build acrylic paint. Follow the paint manufacturer's recommendations to prepare the surface and to adequately cover and conceal the panel fixings.

For site-applied finishes when countersunk screws are used, the recommendation is one coat of acrylic primer and two coats of high build acrylic paint (total DFT not less than 150 microns).

## 8.2 FLEXIBLE SEALANT

Sealant used must comply with the relevant requirements of the NZBC. Their application and usage must be in accordance with the manufacturer's instructions. Check with the sealant manufacturer prior to coating over sealant. Some sealant manufacturers do not recommend coating over their product.

## 8.3 EPOXY FILLERS

All countersunk screw holes must be filled with a two part epoxy e.g. Nuplex® Fairing Cream or a similar epoxy filler. The screw and screw holes must be clean and dry before they are filled with epoxy. The epoxy filler must be sanded flush with panel surface. Always refer to the epoxy manufacturer recommendation before use.

# 9 Storage and handling

Titan Façade Panel, CLD Structural Cavity Batten and RAB Board must be laid flat on a smooth level surface. Edges and corners must be protected from chipping. To ensure optimum performance, store panels under cover and keep dry prior to fixing. If the sheets become wet, allow them to dry thoroughly before fixing. Do not carry sheets or CLD Structural Cavity Battens on the flat, carry in the vertical position to avoid excessive bending.

# 10 Maintenance

The extent and nature of maintenance required will depend on the geographical location and exposure of the building. It is the responsibility of the specifier to determine normal maintenance requirements to maintain the effectiveness of the cladding. As a guide, it is recommended that the basic normal maintenance tasks shall include, but not be limited to:

- Washing down exterior surfaces every 6-12 months\*
- Re-coating exterior protective finishes\*\*
- Regular inspection and repair if necessary of the sealants, Inseal® strips and fillers etc
- Cleaning out gutters, down pipes and overflow pipes as required
- Pruning back vegetation which is close to or touching the cladding as well as ensuring the NZBC ground clearance requirements are maintained especially where gardens are created
- The clearance between the bottom edge of the Titan Façade Panel cladding and the finished/unfinished ground must always be maintained
- Refilling the countersunk holes where the cracks start appearing in the paint film around epoxy fillers or where fastener read through becomes significant

\* Do not use a water blaster to wash down the cladding. In extreme coastal conditions or sea spray zones, wash every 3-4 months.

\*\* Refer to the paint manufacturer for washing down and recoating requirements related to ongoing paint performance.

# 11 Product information

## 11.1 MATERIAL

Titan Façade Panel and RAB Board are high quality autoclaved medium density fibre cement products manufactured by James Hardie. The basic composition is Portland cement, ground sand, cellulose fibre and water. The products are easily identified by the name Titan or RAB written on the rear face. Titan Façade Panel is sealed and primed on the face and back in clear sealed. HomeRAB Pre-Cladding, RAB Board is face sealed.

CLD Structural Cavity Battens are manufactured using a low density fibre cement formulation. The basic composition is Portland cement, ground sand, cellulose fibre, water and proprietary additives. The battens are factory sealed on all sides.

Titan Façade Panels, HomeRAB Pre-Cladding, RAB Board and CLD Structural Cavity Battens are manufactured to AS/NZS 2908.2 'Cellulose-Cement Products' Part 2 (ISO 8336 'Fibre-Cement Flat Sheet'). James Hardie New Zealand Limited is an ISO 9001 'Telarc' certified manufacturer. Titan Façade Panel, HomeRAB Pre-Cladding, RAB Board and CLD Structural Cavity Battens are classified Type A, Category 3 in accordance with AS/NZS 2908.2 'Cellulose-Cement Products' standard.

The approximate mass of 9mm Titan Façade Panel is 13kg/m<sup>2</sup>. For panel sizes see Table 5.

## 11.2 DURABILITY

Titan Façade Panel, HomeRAB Pre-Cladding, RAB Board and CLD Structural Cavity Batten installed and maintained as per this technical specification will meet the durability requirement for claddings as per 'B2 Durability' clause of the NZBC.

### 11.2.1 Resistance to Moisture/Rotting

Titan Façade Panel, HomeRAB Pre-Cladding, RAB Board and CLD Structural Cavity Batten has demonstrated resistance to permanent moisture induced deterioration (rotting) and has passed the following tests in accordance with AS/NZS 2908.2:

- Heat Rain (Clause 6.5)
- Water Permeability (Clause 8.2.2)
- Warm Water (Clause 8.2.4)
- Soak Dry (Clause 8.2.5)

### 11.2.2 Control of External Fire Spread

Titan Façade Panel meets the requirements of Appendix 'C' of C/AS2-6 and is suitable for use where 'non-combustible' cladding materials are required to comply with paragraph 5.8.1 of C/AS2-6 of the NZBC.

### 11.2.3 Alpine Regions

In regions subject to freeze/thaw conditions, Titan Façade Panel, HomeRAB Pre-Cladding, RAB Board and CLD Structural Cavity Battens must not be in direct contact with snow and/or ice build up for extended periods, e.g. external walls in alpine regions be cleared from snowdrifts over winter. These products have been tested for resistance to frost in accordance with AS/NZS 2908.2 Clause 8.2.3.

# 12 Safe working practices

## 12.1 STAY HEALTHY WHEN WORKING WITH BUILDING PRODUCTS CONTAINING CRYSTALLINE SILICA

---

### Crystalline Silica

What is it? Why and when is it a health hazard?

### Crystalline Silica is

- Commonly known as sand or quartz
- Found in many building products e.g. concrete, bricks, grout, wallboard, ceramic tiles, and all fibre cement materials

### Why is Crystalline Silica a health hazard?

- Silica can be breathed deep into the lungs when present in the air as a very fine (respirable) dust
- Exposure to silica dust without taking the appropriate safety measures to minimise the amount being breathed in, can lead to a potentially fatal lung disease – silicosis – and has also been linked with other diseases including cancer. Some studies suggest that smoking may increase these risks
- The most hazardous dust is the dust you cannot see!

### When is Crystalline Silica a health hazard?









- It's dangerous to health if safety protocols to control dust are not followed when cutting, drilling or rebating a product containing crystalline silica
- Products containing silica are harmless if intact (e.g. an un-cut sheet of wall board)

**FAILURE TO ADHERE TO OUR WARNINGS, SAFETY DATA SHEETS AND INSTALLATION INSTRUCTIONS WHEN WORKING WITH JAMES HARDIE PRODUCTS MAY LEAD TO SERIOUS PERSONAL INJURY OR DEATH.**

## 12.2 AVOID BREATHING IN CRYSTALLINE SILICA DUST!

---

### Safe working practices

-  NEVER use a power saw indoors or in a poorly ventilated area
-  NEVER dry sweep
-  ALWAYS use M Class extractor unit as a minimum and always hose down with water/wet wipe for clean up
-  NEVER use grinders
-  ALWAYS use a circular sawblade specifically designed to minimise dust creation when cutting fibre cement – preferably a sawblade that carries the HardieBlade™ logo or one with at least equivalent performance
-  ALWAYS follow tool manufacturers' safety recommendations
-  ALWAYS expose only the minimum required depth of blade for the thickness of fibre cement to be cut
-  ALWAYS wear an approved properly-fitted, approved dust mask (P1 or P2) or respirator

Use one of the following methods based on the required cutting rate:





### BEST

- HardieKnife™
- Hand guillotine
- Fibreshear





### BETTER

- Dust reducing circular saw equipped with HardieBlade™ Saw Blade and M Class extractor unit.

### Working outdoors

-  Make sure you work in a well ventilated area
-  Position cutting station so wind will blow dust away from yourself and others in the working area
-  Cut products with either a HardieKnife™ or fibre cement shears or, when not feasible, use a HardieBlade™ Saw Blade (or equivalent) and a dust-reducing circular saw attached to a M Class extractor unit
-  When sawing, sanding, rebating, drilling or machining fibre cement products, always:
  - Wear your P1 or P2 mask (correctly fitted in accordance with manufacturers' instructions) and when others are close by, ask them to do the same
  - If you are not clean shaven, then use a powered air respirator with a loose fitting head top
  - Wear safety glasses
  - Wear hearing protection
  - When others are close by, ask them to do the same

### Working indoors

-  Never cut using a circular saw indoors
-  Position cutting station in a well ventilated area
-  Cut ONLY using a HardieKnife™, hand guillotine or fibreshears (manual, electric or pneumatic)
-  Make sure you clean up BUT never dry sweep. Always hose down with water/wet wipe or use an M Class extractor unit

**IF CONCERN STILL EXISTS ABOUT EXPOSURE LEVELS OR YOU DO NOT COMPLY WITH THE ABOVE PRACTICES, YOU SHOULD ALWAYS CONSULT A QUALIFIED INDUSTRIAL HYGIENIST.**

### Working Instructions

- Refer to Recommended Safe Working Practices before starting any cutting or machining of product

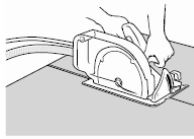

### HardieBlade™ Saw Blade

The HardieBlade™ Saw Blade used with a dust-reducing saw is ideal for fast, clean cutting of James Hardie fibre cement products. A dust-reducing saw uses a dust deflector or a dust collector connected to a vacuum system. When sawing, clamp a straight-edge to the sheet as a guide and run the saw base plate along the straight edge when making the cut

### Hole-Forming

#### For smooth clean cut circular holes:

- Mark the centre of the hole on the sheet
- Pre-drill a 'pilot' hole
- Using the pilot hole as a guide, cut the hole to the appropriate diameter with a hole saw fitted to a heavy duty electric drill

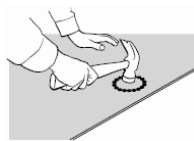

#### For irregular holes:

- Small rectangular or circular holes can be cut by drilling a series of small holes around the perimeter of the hole then tapping out the waste piece from the sheet face
- Tap carefully to avoid damage to sheets, ensuring that the sheet edges are properly supported

## 12.3 STORAGE AND DELIVERY

### Keeping products and people safe

#### Off loading

- 👍 James Hardie products should be off-loaded carefully by hand or by forklift
- 👍 James Hardie products should not be rolled or dumped off a truck during the delivery to the jobsite

#### Storage

##### James Hardie products should be stored:

- 👍 In their original packaging
- 👍 Under cover where possible or otherwise protected with a waterproof covering to keep products dry
- 👍 Off the ground – either on a pallet or adequately supported on timber or other spacers
- 👍 Flat so as to minimise bending

##### James Hardie products must not be stored:

- 👎 Directly on the ground
- 👎 In the open air exposed to the elements

**JAMES HARDIE IS NOT RESPONSIBLE FOR DAMAGE DUE TO IMPROPER STORAGE AND HANDLING.**

## 12.4 TIPS FOR SAFE AND EASY HANDLING

### Weatherboard products

- 👍 Do not lift planked products flat and in the middle
- 👍 Carry the products on the edge
- 👍 If only one person is carrying the product, hold it in the middle and spread arms apart to better support the product
- 👍 If two people are carrying the plank, hold it near each end and on edge
- 👍 Exercise care when handling weatherboard products to avoid damaging the edges/corners

### Sheet products

- 👍 Carry with two people
- 👍 Hold near each end and on edge
- 👍 Exercise care when handling sheet products to avoid damaging the edges/corners



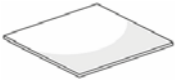

# 13 Product and accessories

Table 5

| Titan Façade Panel information  |  |                |             |            |        |
|---|--|----------------|-------------|------------|--------|
| Product   | Description  | Size           |             |            | Code   |
|   |  | Thickness (mm) | Length (mm) | Width (mm) |        |
|  | <b>Titan Façade Panel</b><br>A square edge panel for expressed jointed building façades. Titan Façade Panel is primed with a distinctive primer, which accepts a wide range of paint finishes. The panel must be installed with the primed side facing outwards. | 9              | 2400        | 1190       | 403023 |
|   |  | 9              | 2700        | 1190       | 403022 |
|   |  | 9              | 3000        | 1190       | 403021 |











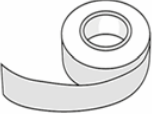

All dimensions and masses provided are approximate only and subject to manufacturing tolerances.

Table 6

| Accessories/tools supplied by James Hardie  |   |  |                                      |
|---|---|--|--------------------------------------|
|   | Description   | Quantity/size (approx)                                   | Product code                         |
|    | <b>CLD Structural Cavity Batten</b><br>19mm thick fibre cement cavity batten installed over RAB Board or a building underlay. Titan Façade Panels are fixed to the battens. | 19 x 70mm, 2450mm long<br>Pack of 96 battens             | 403870                               |
|    | <b>Aluminium 'T' Socket</b><br>T socket is used to form a horizontal negative joint.  | 2400mm and 3000mm  | 304103<br>304105                     |
|   | <b>JH 9mm Panel Aluminium External Box Corner</b><br>A box corner mould to form the external joints. 9mm etch primed.   | 2450mm long<br>2750mm long<br>3000mm long<br>4000mm long | 304509<br>304510<br>305150<br>305808 |
|  | <b>James Hardie Countersunk Tungsten Carbide Drill Bit</b><br>9mm Countersinking bit.   | Each   | 300567                               |
|  | <b>Annular Threaded Nail</b><br>25 x 2.5mm nail.  | 500gm  | 300390                               |
|  | <b>Nylon Washer</b><br>Neoprene washer is used to between the panel and screw head for weather tightness.   | 1,000 per pack   | 302761                               |
|  | <b>CLD Batten Flashing Aluminium</b><br>Used to flash the battens normally at floor joist levels.   | Pack of 20   | 304651                               |
|  | <b>CLD Batten Corner Flashing Aluminium</b><br>Used to flash the battens around corners at floor joist levels.  | Pack of 20   | 304652                               |
|  | <b>uPVC Vent Strip</b><br>75mm x 18mm wide x 3000mm   | 25 per pack  | 302490                               |
|  | <b>uPVC Horizontal Flashing</b><br>For RAB Board horizontal joint.  |  | 305152                               |
|  | <b>HardieBlade™ Saw Blade</b><br>Diamond tip 184mm diameter fibre cement circular saw blade. Spacers not included.  | Each   | 300660                               |
|  | <b>HardieKnife™</b>   |  | 305926                               |

## Accessories/tools not supplied by James Hardie

James Hardie recommends the following products for use in conjunction with Titan Façade Panel, HomeRAB Pre-Cladding, RAB Board and CLD Structural Cavity Batten. James Hardie does not supply these products and does not provide a warranty for their use. Please contact component manufacturer for information on their warranties and further information on their products.

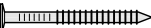
| Product  | Description   |
|--|---|
|   | Flexible Underlay<br>Must comply with Table 23 of E2/AS1  |
|   | Flexible Window Opening Flashing Tape<br>A flexible self-adhesive tape used in preparation of a window. Refer to the window installation section in this manual for more information. e.g. SUPER-STICK Building Tape® or 3m™ All Weather Flashing Tape 8067 by 3M<br>Marshall Innovations: 0800 776 9727<br>3M™: 0800 474 787   |
|   | HomeRAB Pre-Cladding/RAB Board Vertical Joint Sealing Tape<br>The tape to be used to seal HomeRAB Pre-Cladding/ RAB Board vertical joints.<br>SUPER-STICK Building Tape® by Marshall Innovations or 3M™ All Weather Flashing Tape 8067 by 3M<br>Marshall Innovations: 0800 776 9727<br>3M™: 0800 474 787  |
|   | Polypropylene DPC Tape 200mm wide<br>Product used over flexible underlay at external and internal corners   |
|   | Titanium Drill Bit<br>Used to pre-drill clearance holes for exposed head screws.  |
|    | Epoxy Flush Sealing (2 Part)<br>Countersunk head screws are flush sealed using Nuplex Fairing cream or similar epoxy.   |
|   | ADOS CRC Builders Fill to skim over brad nails  |
|   | Adhesive Sealant<br>Sikaflex-11FC Polyurethane adhesive sealant manufactured by Sika® for applying between the panels and battens. Refer to section 7 for more information.<br>SIKA 0800 SIKANZ.<br>Seal N Flex-1 Polyurethane adhesive sealant manufactured by Bostik for applying between the panels and battens. Refer to section 7 for more information.<br>Bostik: AKL: (09) 579 6253, WGTN: (04) 567 5119, CHCH: (03) 366 2583. |
|   | Flexible Sealant<br>Required to seal the vertical joints. Bostik Seal N Flex-1, Sikaflex AT-Façade or similar.  |
| <b>Fasteners</b>   |   |
|   | Countersunk Screw<br>25mm x 8-10g countersunk screws (Class 3/4 or stainless steel) for fixing of Titan Façade Panels to CLD Structural Cavity Battens.<br>EDL stainless steel 304 screw square drive CODE: 03S101T17US.<br>Black Fasteners stainless steel 304 Code: WSSFSSQ08M.   |
|   | Exposed Head Fasteners<br>25mm x 8-10g pan head screws (Class 3/4 or stainless steel) for fixing of Titan Façade Panels to CLD Structural Cavity Battens.   |
|   | C-25 Stainless Steel Brad Nails<br>304SS brad nails used to install Titan Façade Panels to the CLD Structural Cavity Battens using a straight bradder. Paslode: (09) 477 3000   |
|   | 65 x 2.87mm RounDrive Ring Shank Nail<br>For fixing CLD Structural Cavity Battens to the framing.<br>Paslode: (09) 477 3000   |
|   | HardieFlex™ Hot Dipped Galvanised and Stainless Steel 316 Nail<br>For HomeRAB Pre-Cladding/RAB Board Fixing. 40 x 2.8mm   |
| <b>Sika, Sikaflex, Bostik, Seal N Flex, 3M, Resene, Paslode, Protecto Wrap, Dulux AcraPrime, are trademarks registered to their manufacturers.</b> |   |

# 14 Details

Various details outlined in the following table are available on pages 16 to 38

| Details   |           |      |
|---|-----------|------|
| Description   | Figure    | Page |
| Framing setout  | Figure 1  | 16   |
| Batten fixing setout  | Figure 2  | 16   |
| Panel layout options  | Figure 3  | 17   |
| Panel fixing setout   | Figure 4  | 17   |
| Foundation detail   | Figure 5  | 18   |
| Vertical expressed joint using 'T' head brad nails              | Figure 6  | 18   |
| Intermediate stud fixing using 'T' head brad nails              | Figure 7  | 19   |
| Alternate vertical expressed joint using annular threaded nails | Figure 8  | 19   |
| Alternate intermediate stud fixing using annular threaded nails | Figure 9  | 20   |
| Alternate vertical expressed joint using countersunk screws     | Figure 10 | 20   |
| Alternate intermediate stud fixing using countersunk screws     | Figure 11 | 21   |
| Alternate vertical expressed joint using exposed screws         | Figure 12 | 21   |
| Internal corner   | Figure 13 | 22   |
| External corner   | Figure 14 | 22   |
| Alternate external corner                                       | Figure 15 | 23   |
| Jointing of CLD structural cavity batten                        | Figure 16 | 23   |
| Window sill   | Figure 17 | 24   |
| Window jamb   | Figure 18 | 24   |
| Window head   | Figure 19 | 25   |
| Soffit detail   | Figure 20 | 25   |
| Nil soffit  | Figure 21 | 26   |
| Mid floor aluminium socket joint                                | Figure 22 | 27   |
| 'T' socket joint at floor joist                                 | Figure 23 | 28   |
| 'T' socket joint at floor joist corner                          | Figure 24 | 29   |
| Drained flashing joint at floor joist                           | Figure 25 | 30   |
| Enclosed deck   | Figure 26 | 31   |
| One piece apron flashing joint                                  | Figure 27 | 31   |
| Roof to wall junction detail                                    | Figure 28 | 32   |
| Parapet flashing  | Figure 29 | 32   |
| Meter box at sill   | Figure 30 | 33   |
| Meter box at jamb   | Figure 31 | 33   |
| Meter box at head   | Figure 32 | 34   |
| Socket joint detail at window head                              | Figure 33 | 34   |
| 'T' socket joint at window head                                 | Figure 34 | 35   |
| 'T' socket joint at window jamb                                 | Figure 35 | 36   |
| Cavity pipe penetration   | Figure 36 | 36   |
| Garage head   | Figure 37 | 37   |
| Garage jamb   | Figure 38 | 37   |
| Cavity vertical batten joint                                    | Figure 39 | 38   |
| External corner with facings                                    | Figure 40 | 38   |

Figure 1: Framing setout

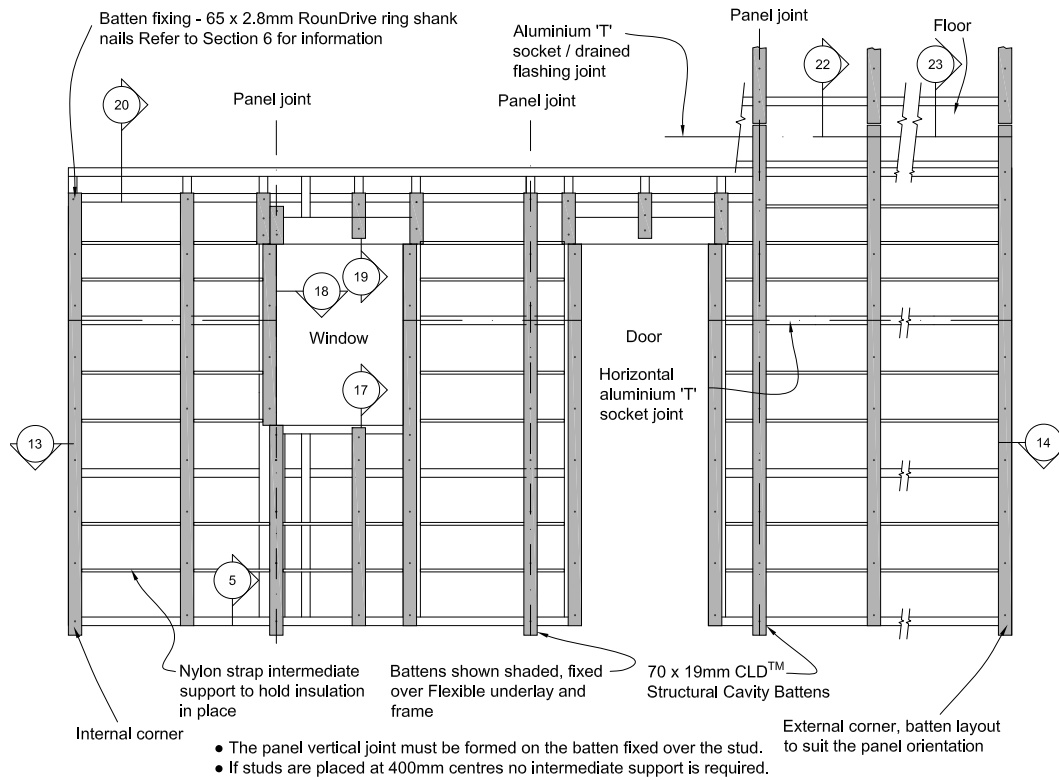

Figure 2: Batten fixing setout

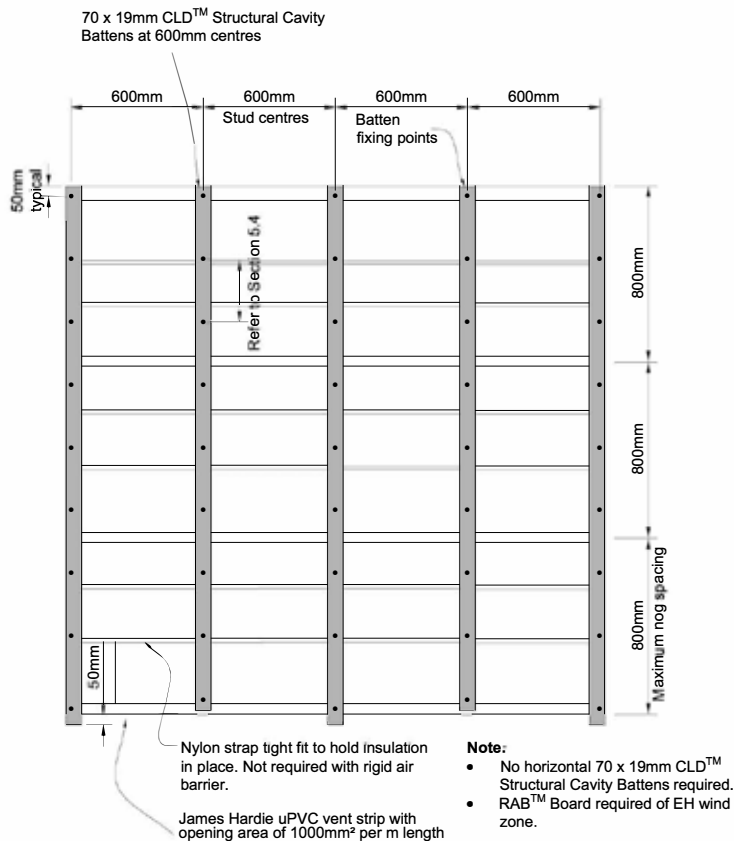



Figure 3: Panel Layout Options

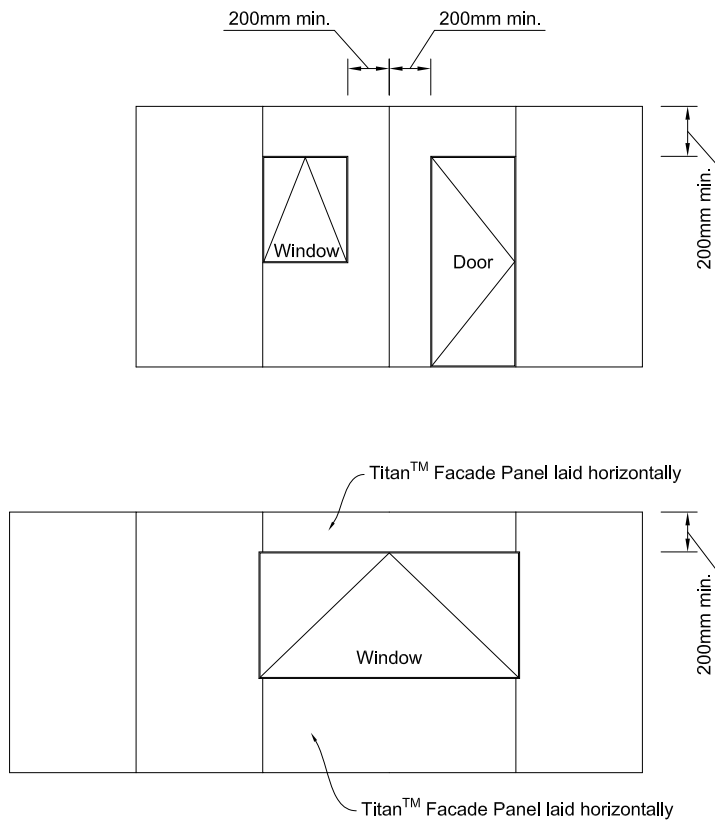

Figure 4: Panel fixing setout

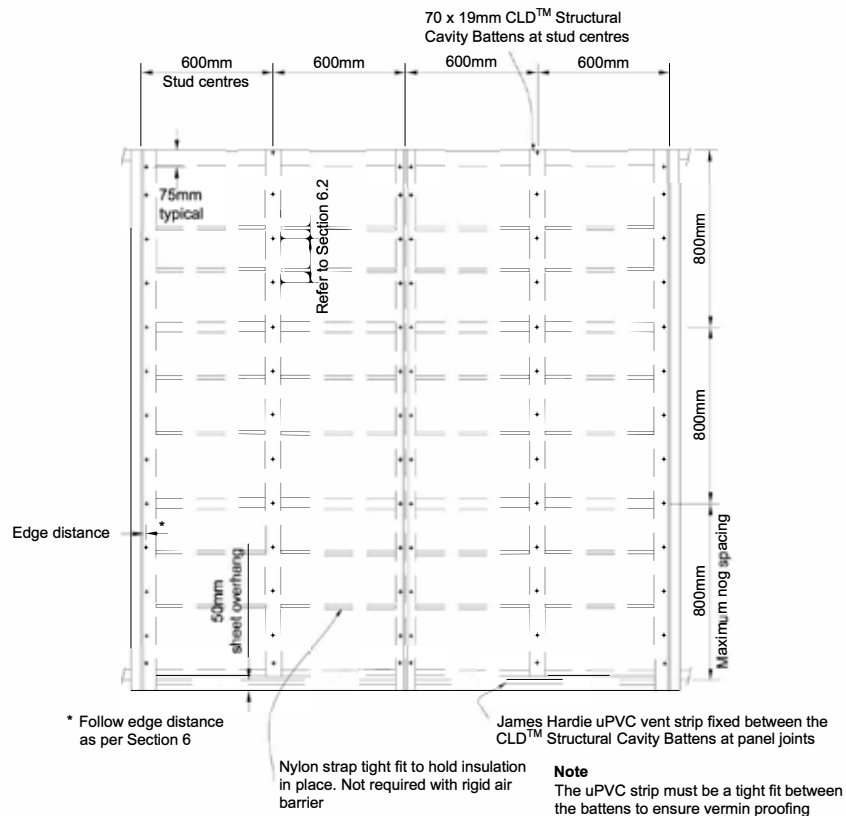
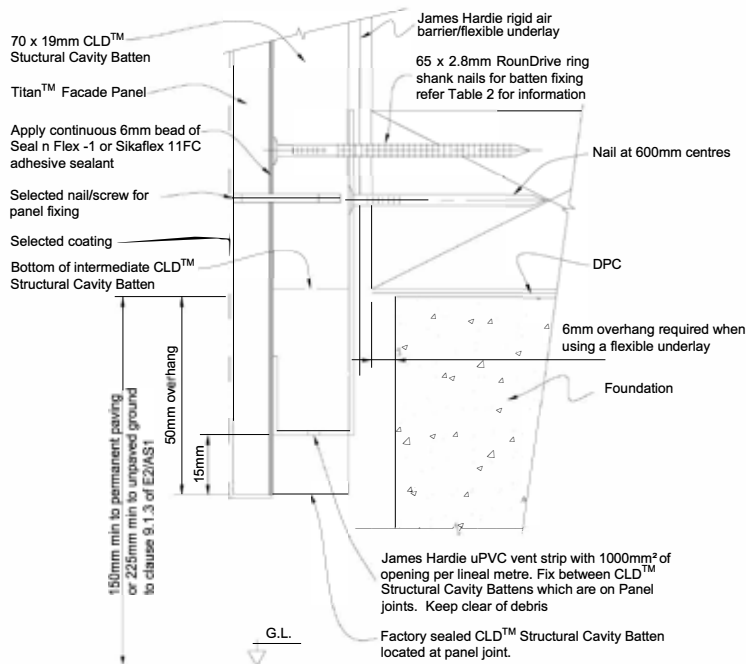

Figure 5: Foundation detail



**Notes:**

- Check panel extends past bottom plate as specified in Architects specification (50mm min).
- uPVC Vent strip must remain level and secure during construction. Cut and fix uPVC vent strip between CLD™ Structural Cavity Battens fixed under the panel joints.
- Check vent strip is free from site debris.
- Refer to Table 3 for Titan™ Facade Panel fixing options.
- Push panel hard against CLD™ Structural Cavity Batten.

Figure 6: Vertical expressed joint using 'T' head brad nails

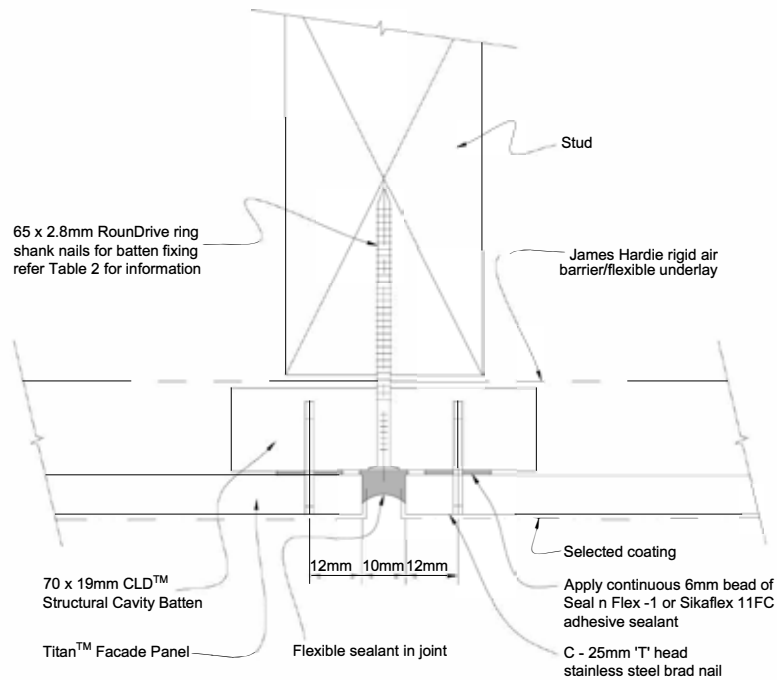

**Notes:**

- Ensure that a continuous 6mm bead of adhesive sealant is applied between CLD™ Structural Cavity Batten and Titan™ Facade Panel.
- Ensure that the required edge distance is maintained when fixing.
- Seal cut edges with a primer compatible with final coatings.
- Refer to Table 3 for Titan™ Facade Panel fixing options.
- Push panel hard against CLD™ Structural Cavity Batten.

Figure 7: Intermediate stud fixing using 'T' head brad nails

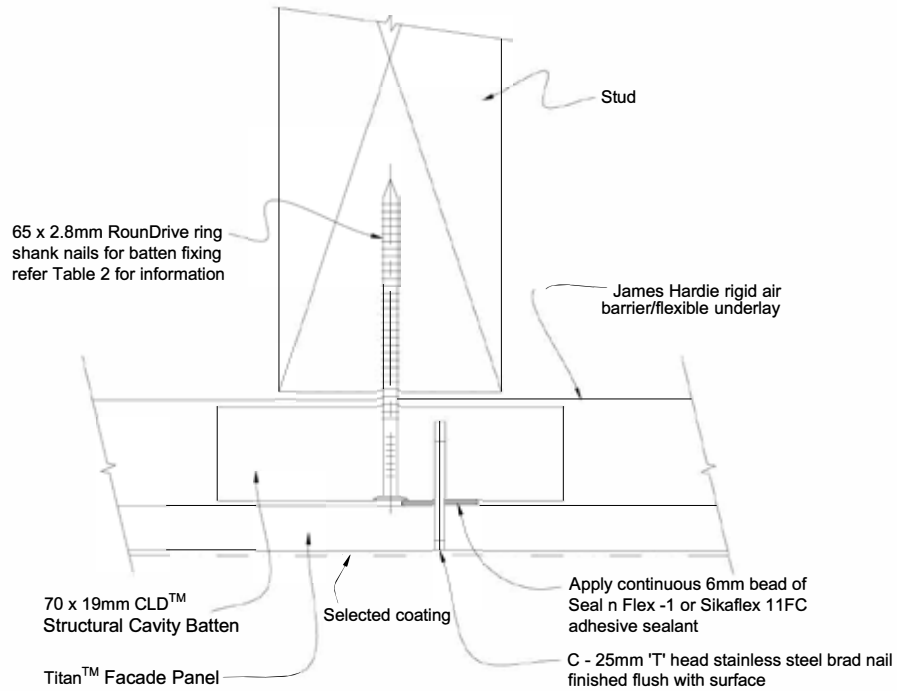

**Notes:**

- Fix panel from the middle of the board outwards.
- Refer to Table 3 for Titan™ Facade Panel fixing options.
- Push panel hard against CLD™ Structural Cavity Batten.

Figure 8: Alternate vertical expressed joint using annular threaded nails

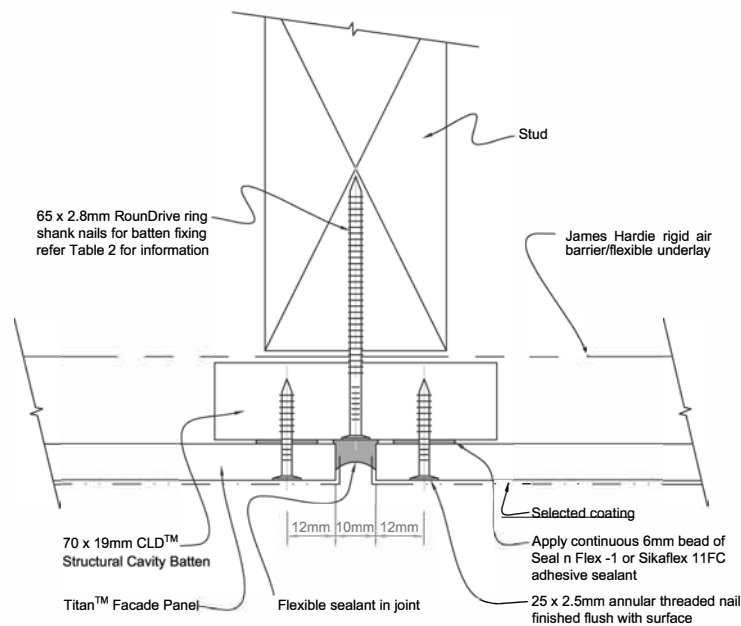

**Notes:**

- Ensure that a continuous 6mm bead of adhesive sealant is applied between CLD™ Structural Cavity Batten and Titan™ Facade Panel.
- Ensure that the required edge distance is maintained when fixing.
- Seal cut edges with a primer compatible with final coatings.
- Refer to Table 3 for Titan™ Facade Panel fixing options.
- Push panel hard against CLD™ Structural Cavity Batten.

Figure 9: Alternate intermediate stud fixing using annular threaded nails

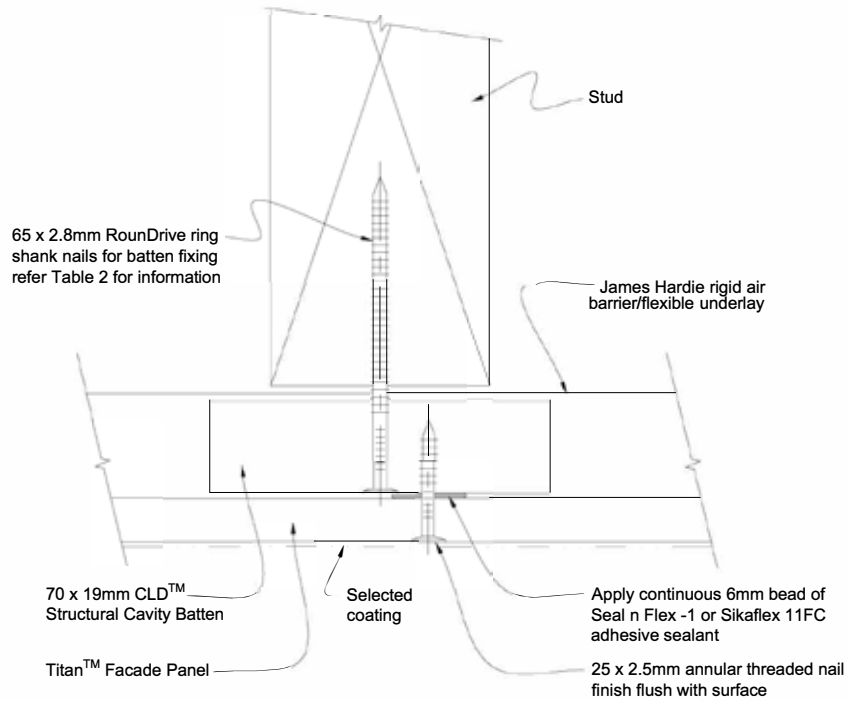

**Notes:**

- Fix panel from the middle of the board outwards.
- Refer to Table 3 for Titan™ Façade Panel fixing options.
- Push panel hard against CLD™ Structural Cavity Batten.

Figure 10: Alternate vertical expressed joint using countersunk screws

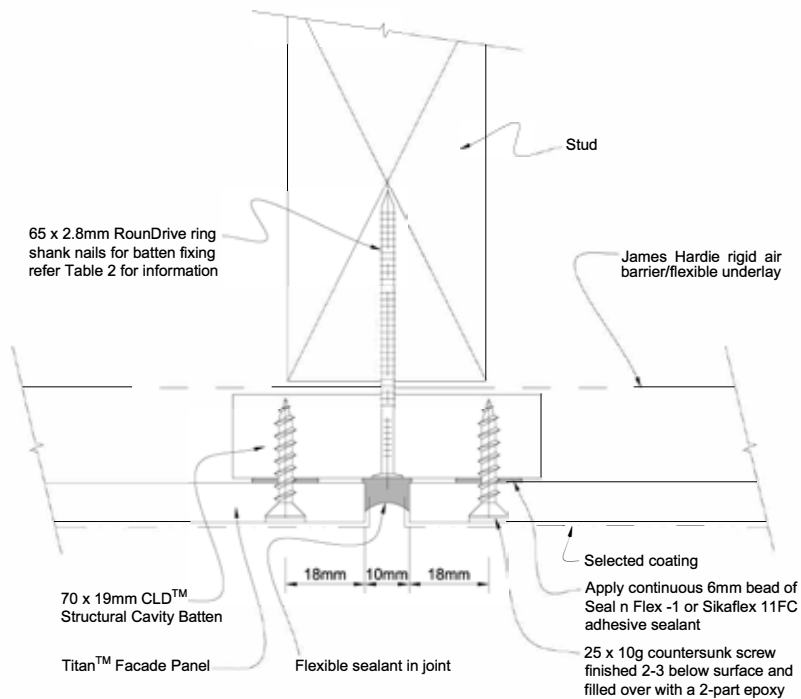

**Notes:**

- Ensure that a continuous 6mm bead of adhesive sealant is applied between CLD™ Structural Cavity Batten and Titan™ Façade Panel.
- Ensure that the required edge distance is maintained when fixing.
- Seal cut edges with a primer compatible with final coatings.
- Refer to Table 3 for Titan™ Façade Panel fixing options.
- Push panel hard against CLD™ Structural Cavity Batten.

Figure 11: Alternate intermediate stud fixing using countersunk screws

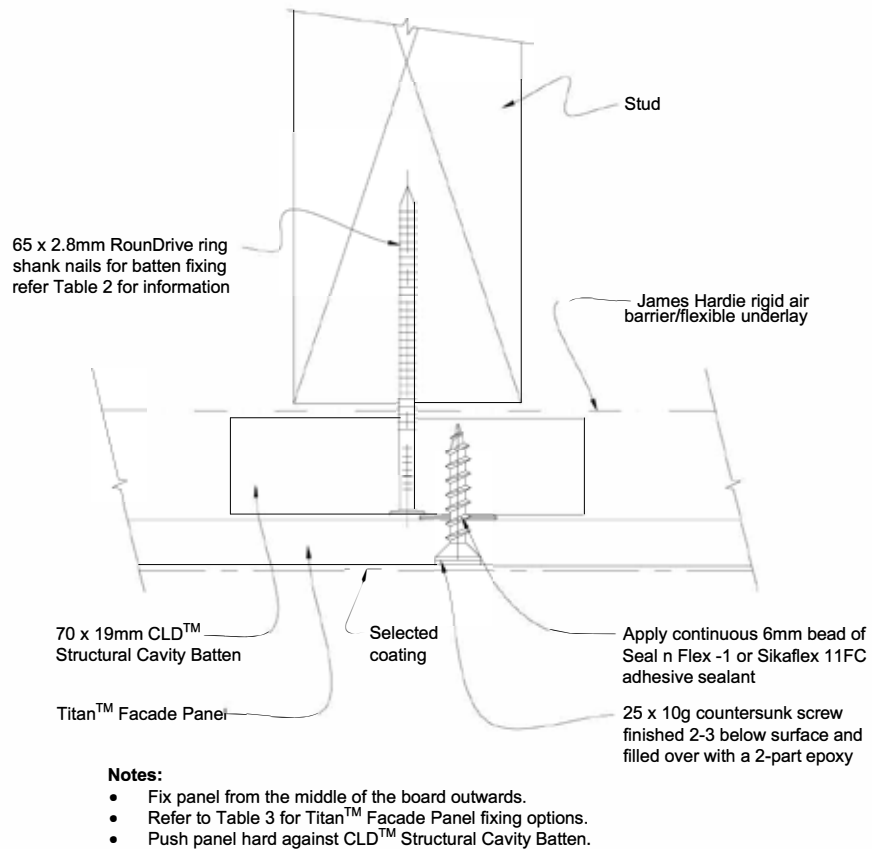

Figure 12: Alternate vertical expressed joint using exposed screws

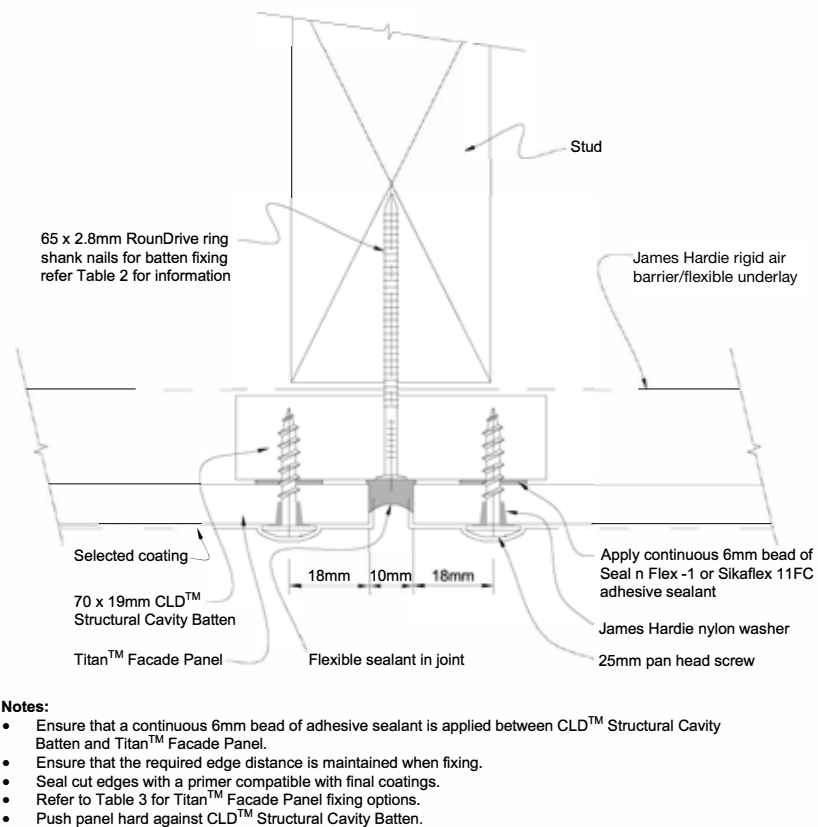

Figure 13: Internal corner

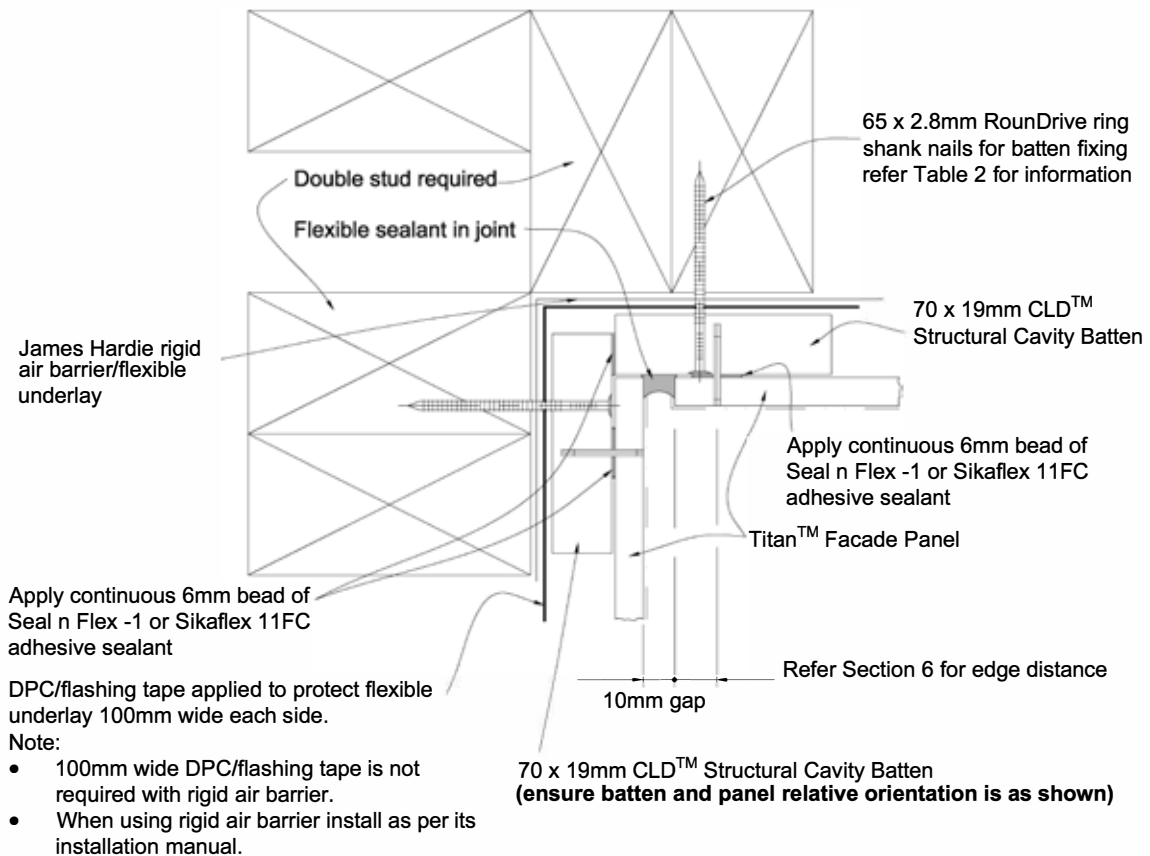

Figure 14: External corner

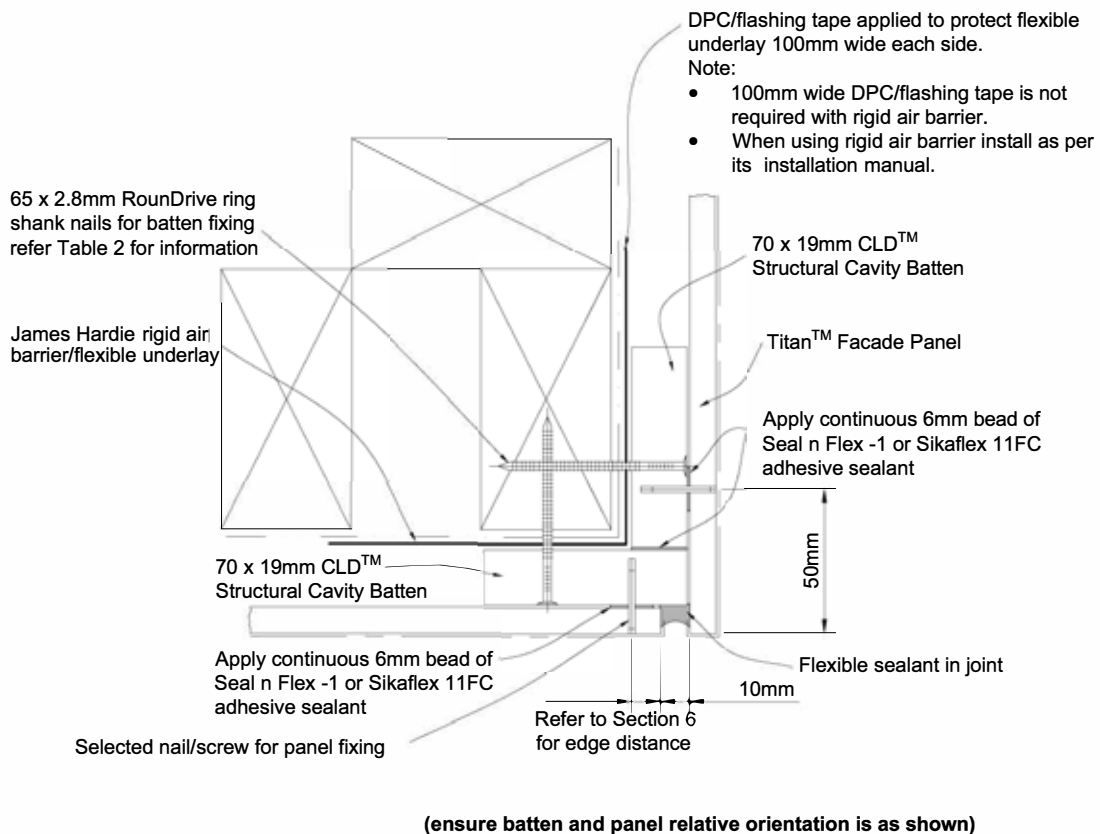

Figure 15: Alternative external corner

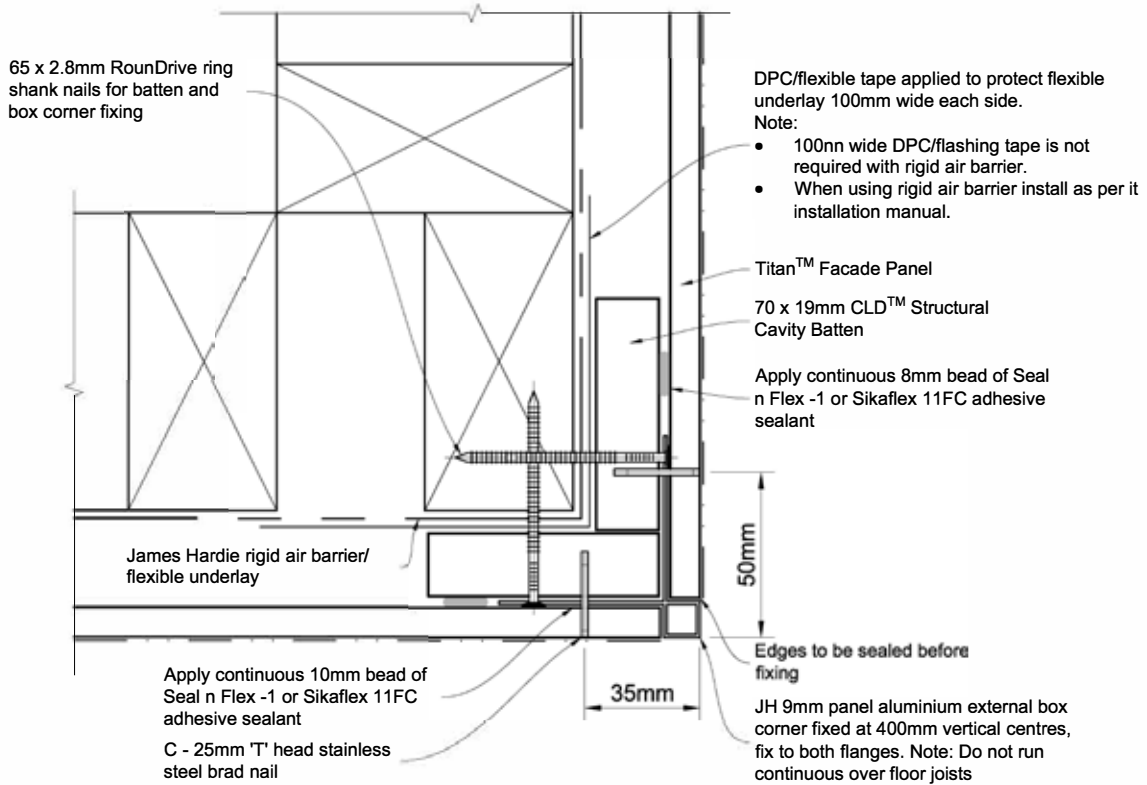

Figure 16: Jointing of CLD Structural Cavity Batten

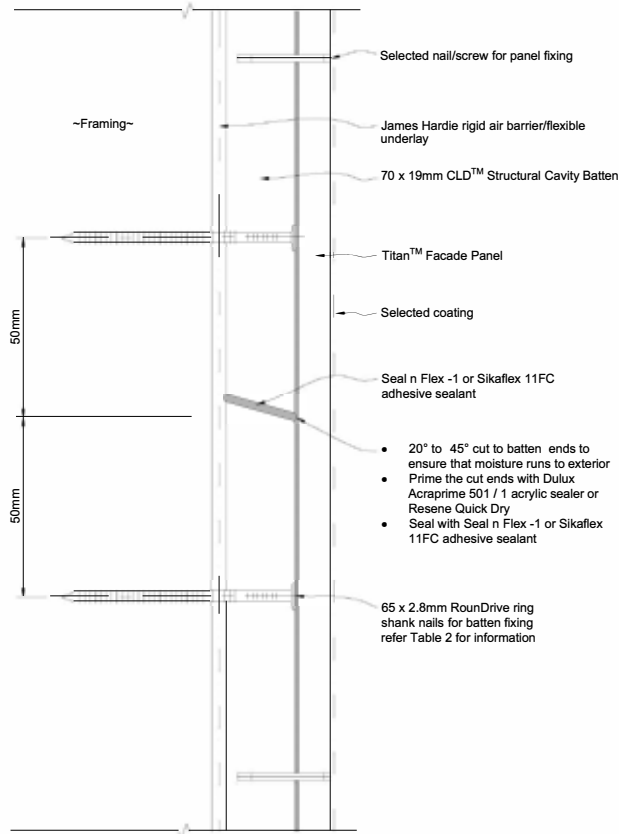
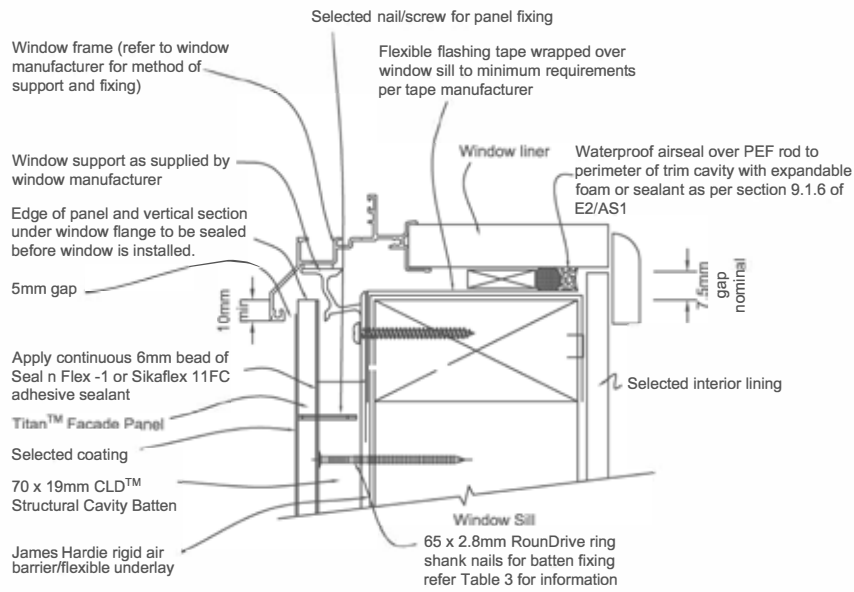

Figure 17: Window sill



**General notes for materials selection**

- Flashing materials must be selected based on environmental exposure, refer to NZS 3604 and Table 20 of NZBC E2/AS1.
- Flashing tape must have proven compatibility with the selected flexible underlay and other materials with which it comes into contact.

Refer to the manufacturer or supplier for technical information for these materials.

Figure 18: Window jamb

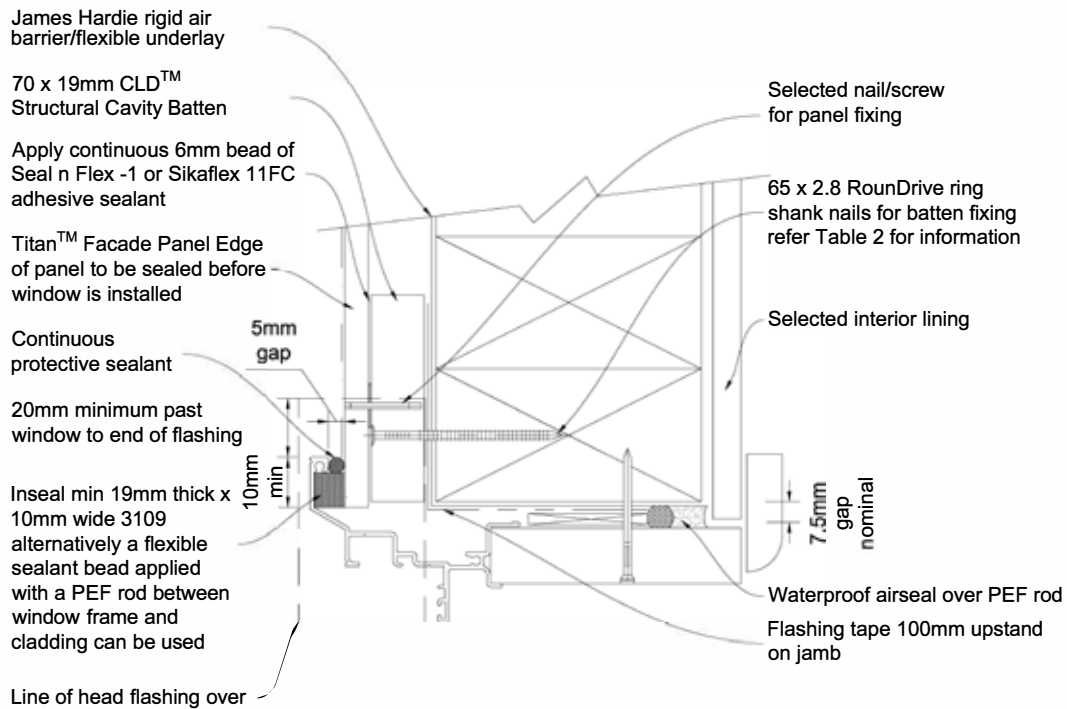

**Note:** When James Hardie rigid air barrier is used flashing tape to be applied to the entire window opening



Figure 19: Window head

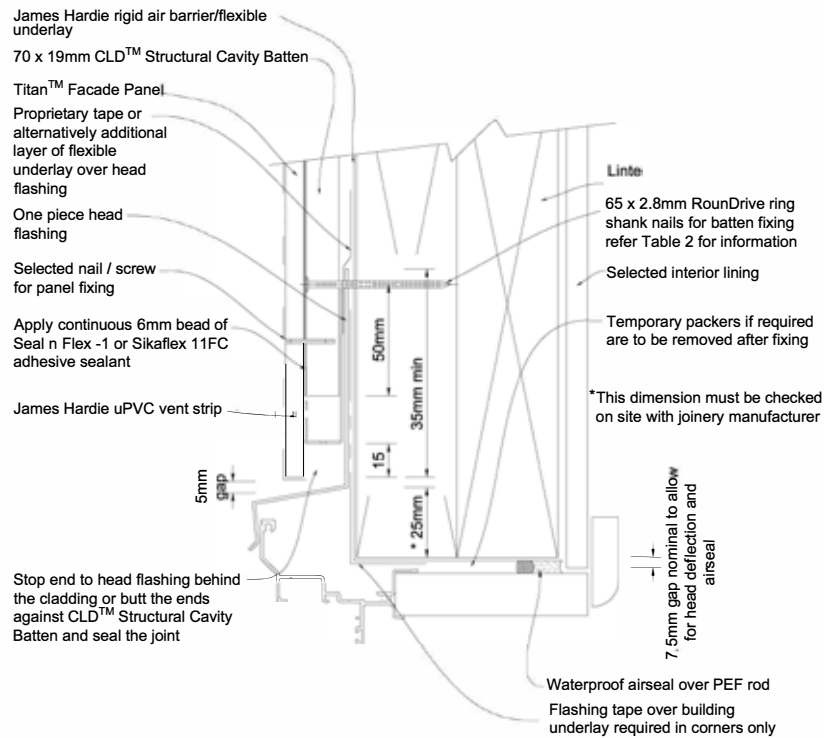

Note:

- When James Hardie rigid air barriers are used flashing tape to be applied to the entire window opening.
- Sealant must be installed between head flashing and window flange in VH and EH wind zones and SED projects.
- Alternatively, the head flashing can be formed with stop ends as per E2/AS1

Figure 20: Soffit detail

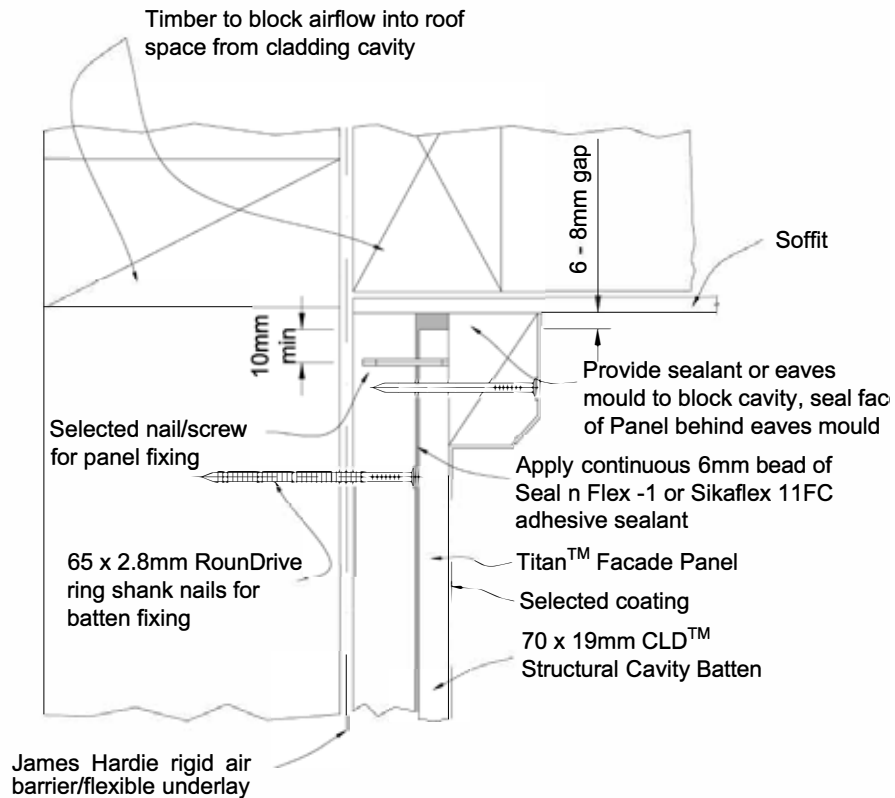

Figure 21: Nil soffit

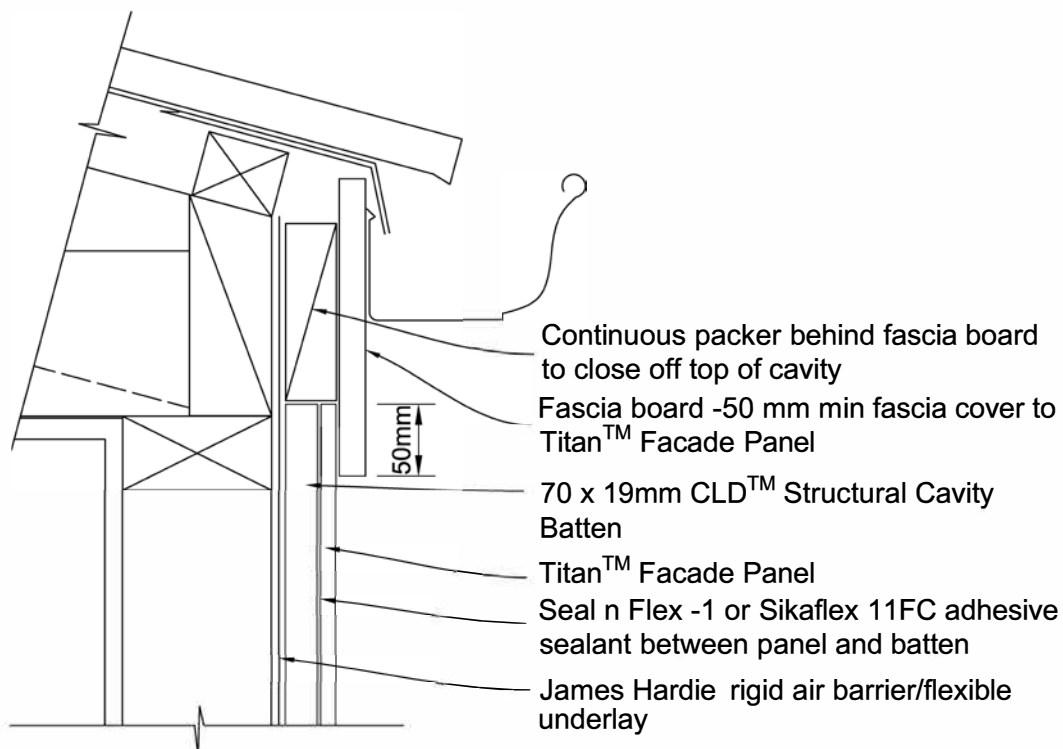
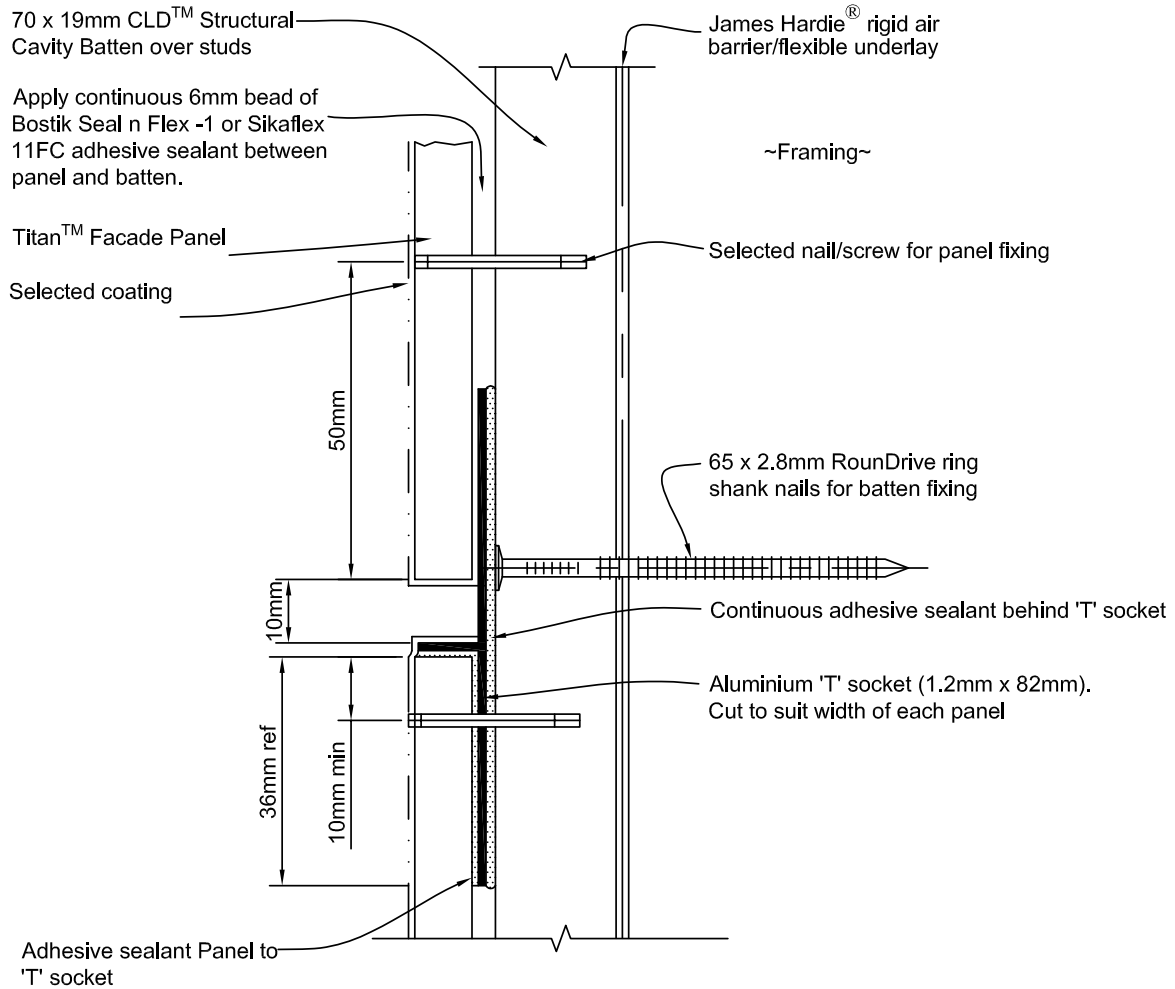

Figure 22: Mid floor aluminium socket joint



**Step 1**

- Ensure that flexible underlay/James Hardie® rigid air barrier is in place.

**Step 2**

- 70 x 19mm CLD™ Structural Cavity Battens to be installed over the studs.
- Nylon strapping intermediate support to be provided to hold insulation in place between studs.

**Step 3**

- Install the lower panel complete with Aluminium 'T' socket.
- Install the upper panel keeping a 10mm gap.

**Notes:**

- The Aluminium 'T' socket can be glued onto the back of the sheet on the ground. Apply two 6mm thick lines of adhesive sealant on the bottom portion of the Aluminium 'T' socket to seal. Take care to ensure continuous seal is formed between the panel and Aluminium 'T' socket. The sealant must continue between socket flange and top panel edge.
- The Aluminium 'T' socket must be sealed using adhesive sealant to the CLD™ Structural Cavity Batten.
- For edge distance of fixings refer to Section 6.
- Push panel hard against CLD™ Structural Cavity Batten.

Figure 23: 'T' socket joint at floor joist

Apply 6mm bead of Bostik Seal n Flex -1 or Sikaflex 11FC adhesive sealant between panel and batten

James Hardie rigid air barrier/flexible underlay

70 x 19mm CLD™ Structural Cavity Batten

Titan™ Facade Panel

75mm wide flashing with 15° slope

Adhesive sealant

120mm

10mm

30mm

10mm

'T' socket

15mm gap

min 10mm

Adhesive sealant panel to Aluminium 'T' socket

Selected coating

65 x 2.8mm RoundDrive ring shank nails for batten fixing

~Bottom plate~

~Top plate~

~Ceiling batten~

~Floor joist~

40mm flashing

Flexible sealant between Panel and 'T' socket

Continuous adhesive sealant behind 'T' socket

**Step 1**

- Check Architect's specification to confirm the type of horizontal joint required.

**Step 2**

- Check fixing centres and edge distances.
- Cut edges need to be primed on site.

**Step 3**

- Flash the horizontal gap between battens with batten flashing and seal as shown.
- Aluminium 'T' socket to be cut flush to the vertical edges of panels and should start below the batten flashing.

**Step 4**

- Do not fix panels or battens into floor joists.
- For edge distance of fixings refer to Section 6.

Figure 24: 'T' socket joint at floor joist corner

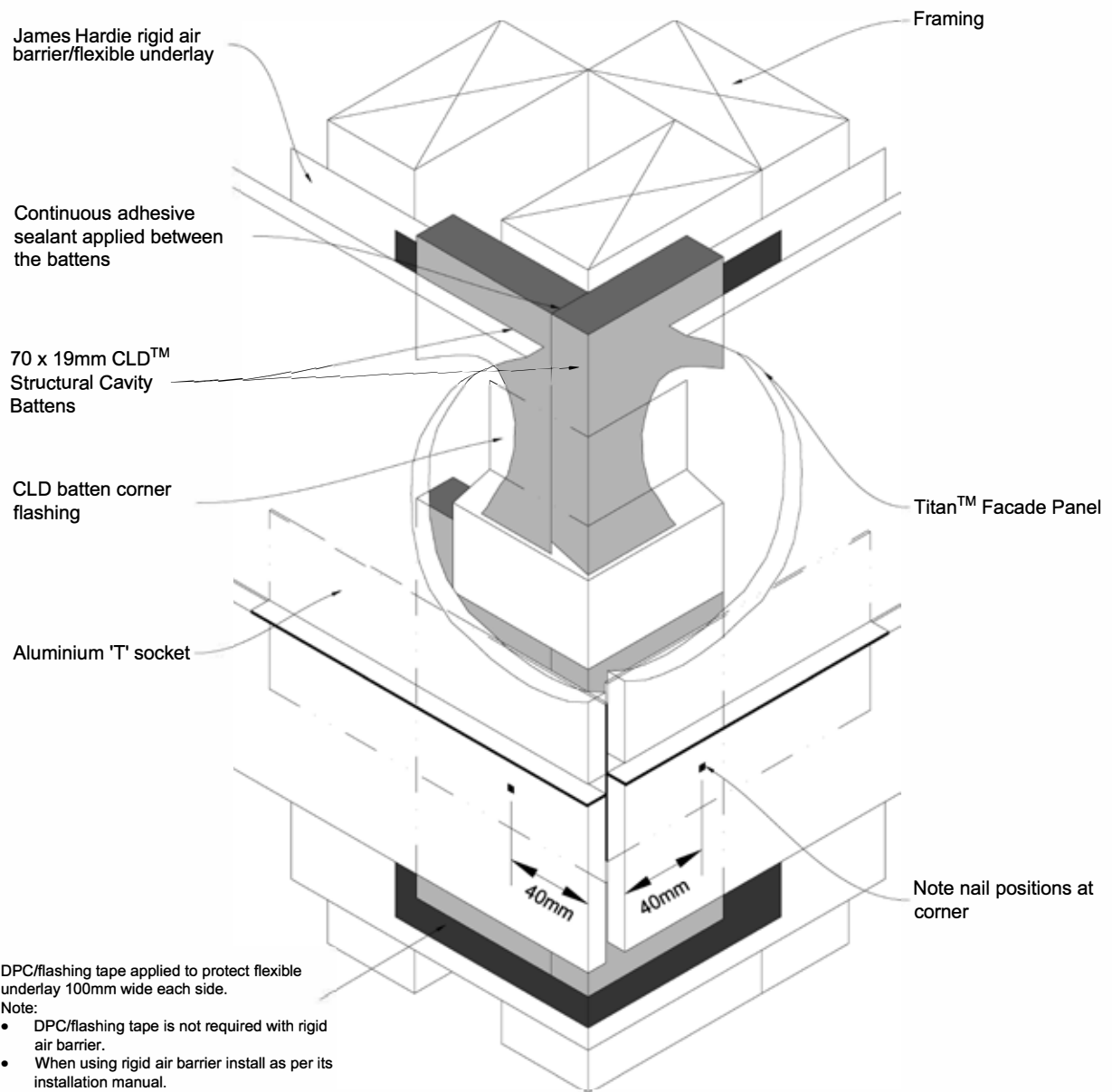

**Note:**

- Socket joint at floor joist for internal corner may be formed using the same CLD corner flashing.
- Refer to Figure 21 for fixing of Aluminium 'T' socket.
- For edge distance of fixings refer to Section 6.

Figure 25: Drained flashing joint at floor joist

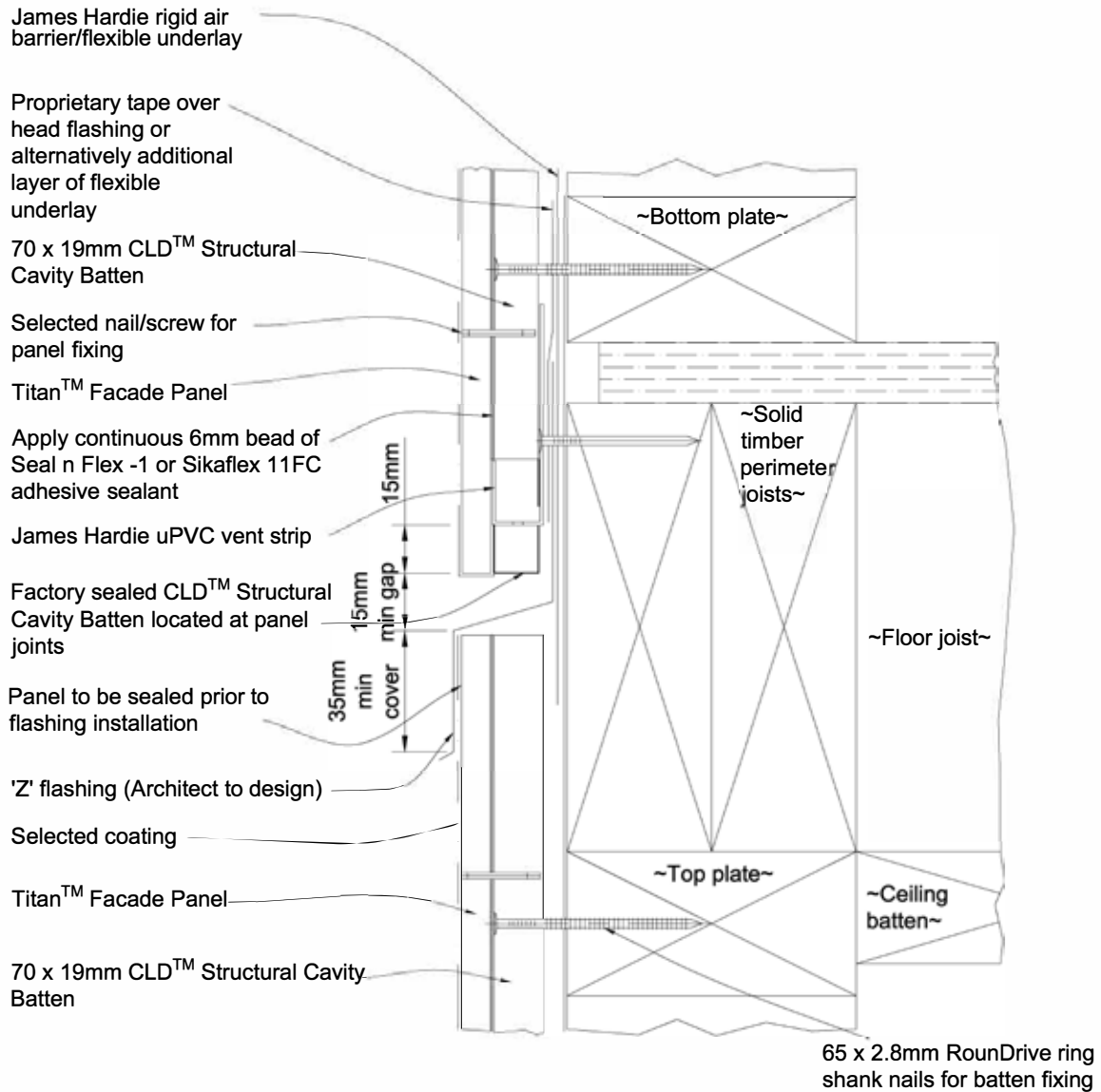

**Step 1**

- Check Architect's plans for the type of flashing to be used.

**Step 2**

- Check fixing centres and edge distances.
- If top fixings are to be hidden by the Z flashing they will need to be fixed and sealed before the Z flashing is installed.
- Cut edges need to be primed with sealer.

**Step 3**

- When 50 year durability is required refer Table 20 E2/AS1.

**Step 4**

- The flashing to be placed in the centre of the floor joists. Do not fix CLD™ Structural Cavity Battens or panels into floor joists.

**NOTE: This detail is required to limit cavities to a minimum of 2 stories or 7 meters. Refer to E2/AS1 clause 9.1.9.4**

Figure 26: Enclosed deck

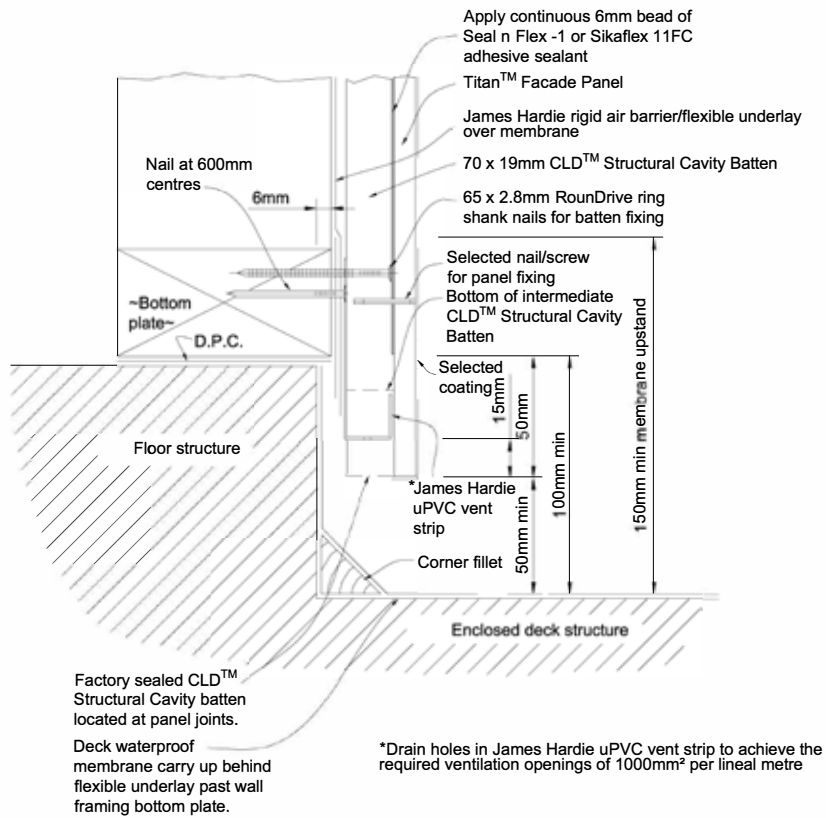

Figure 27: One piece apron flashing joint

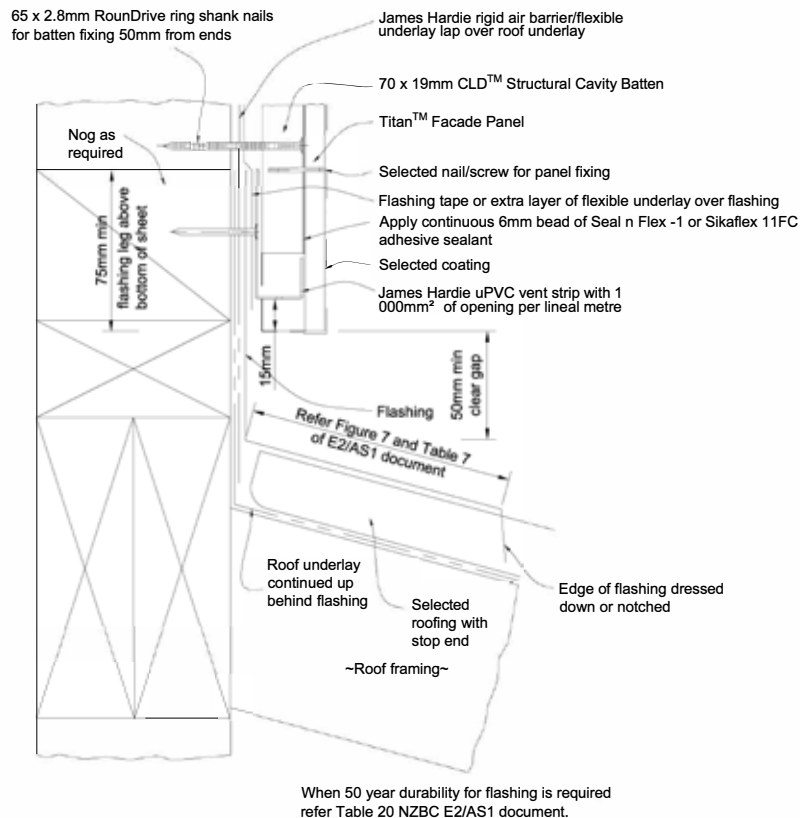

Figure 28: Roof to wall junction detail

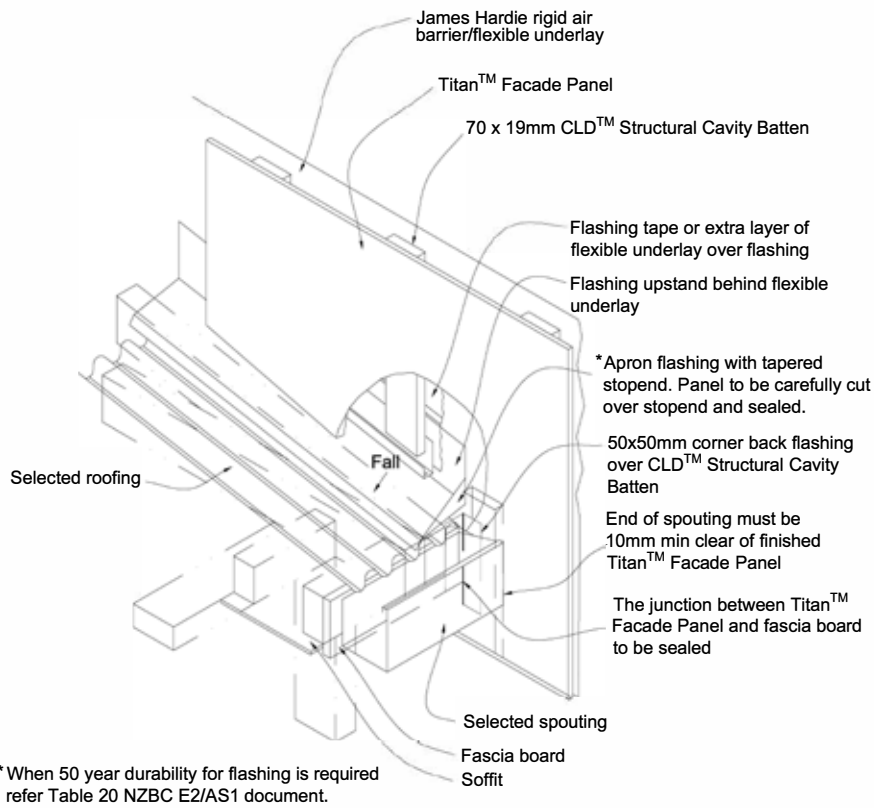

Figure 29: Parapet flashing

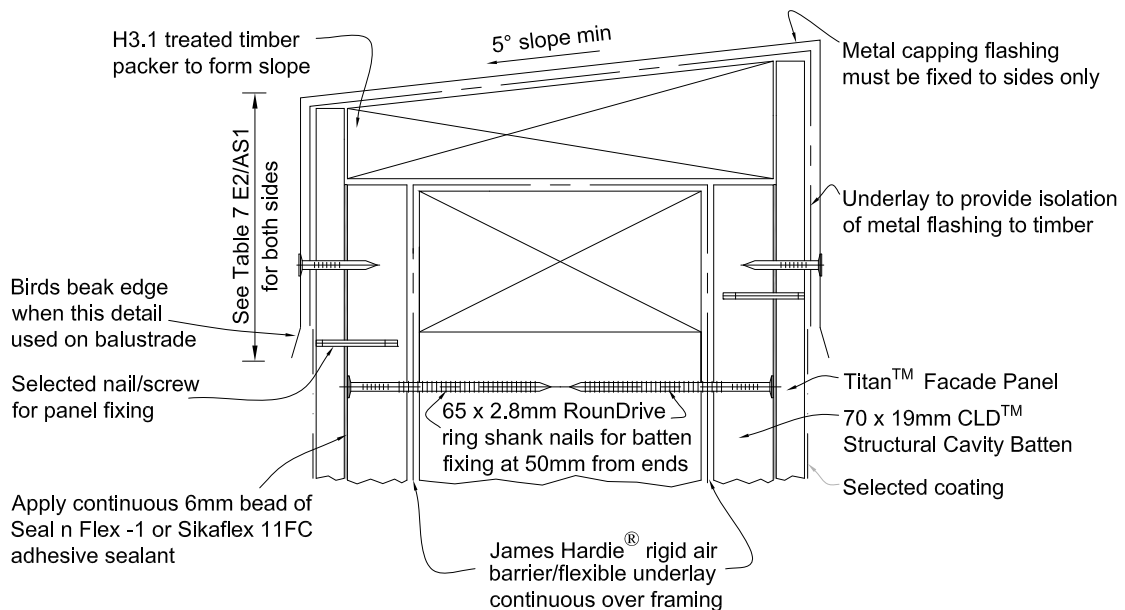



Figure 30: Meter box at sill

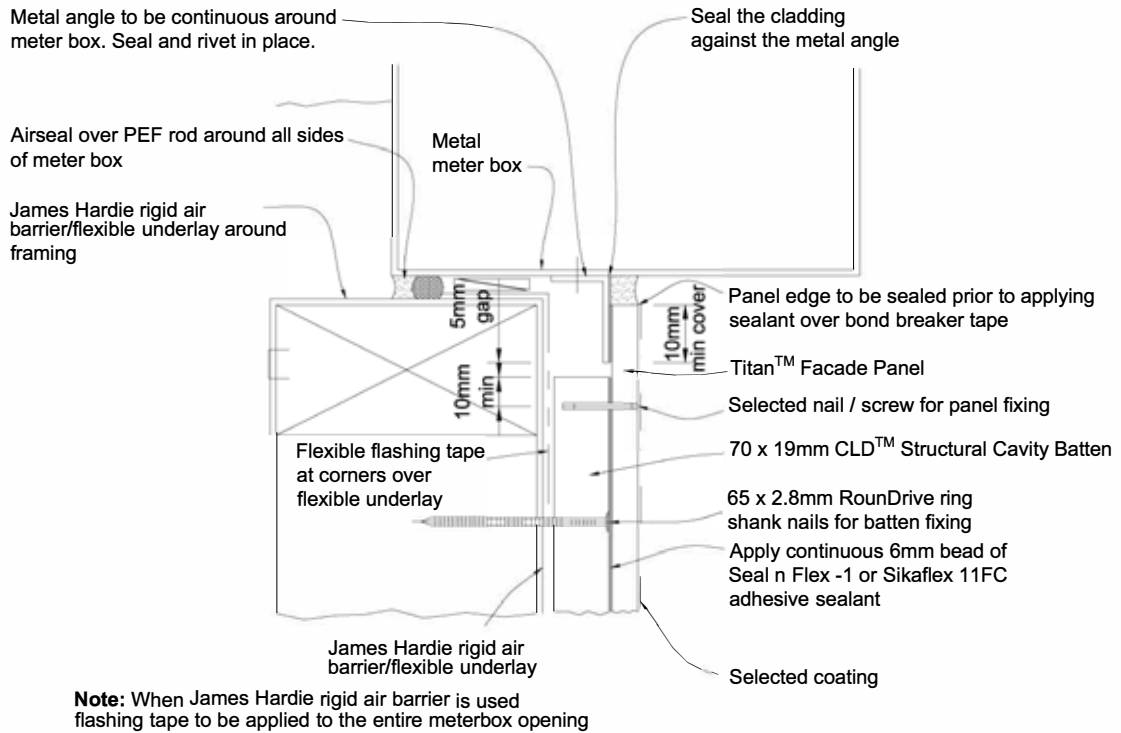

Figure 31: Meter box at jamb

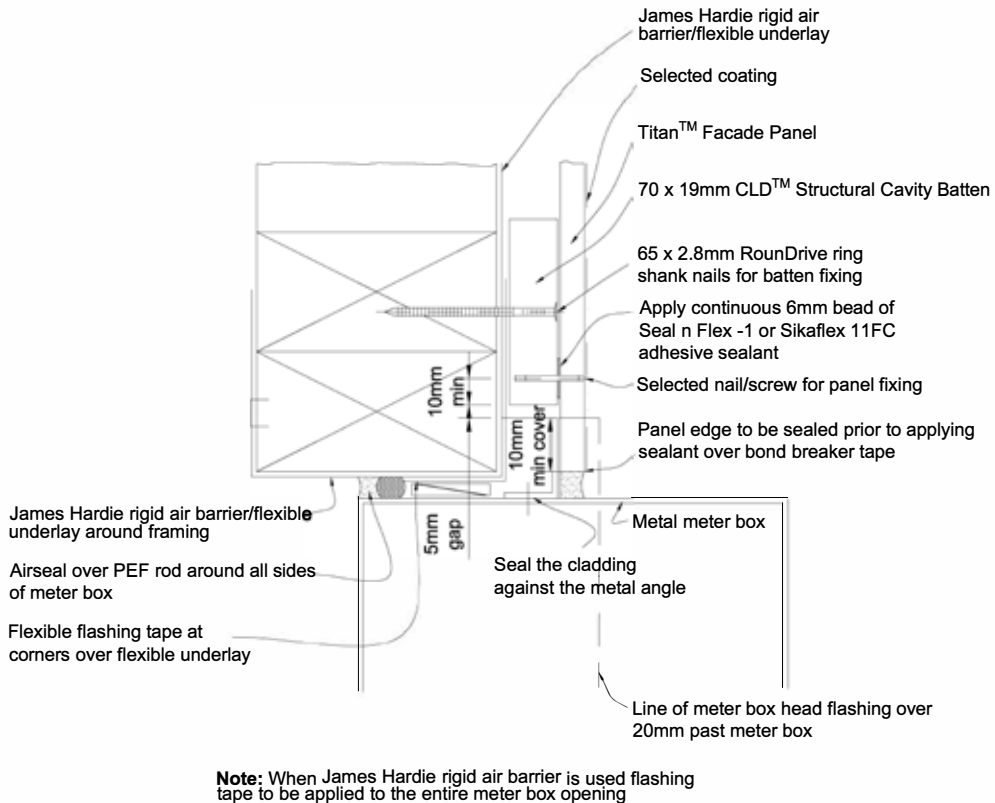

Figure 32: Meter box at head

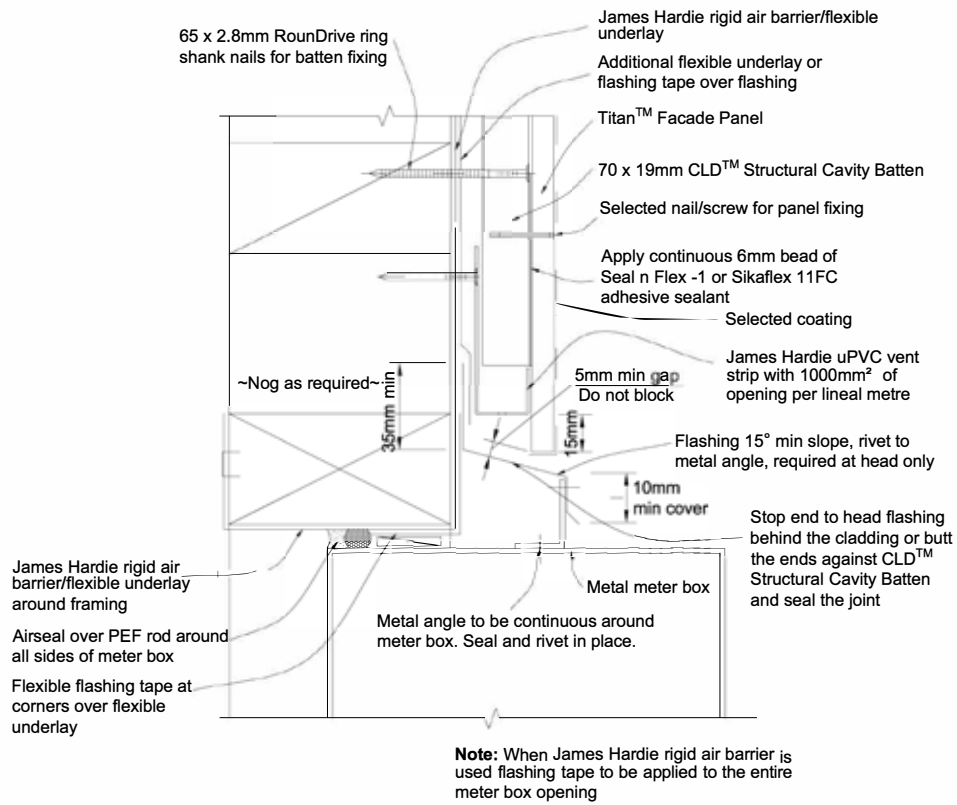

Figure 33: Socket joint detail at window head

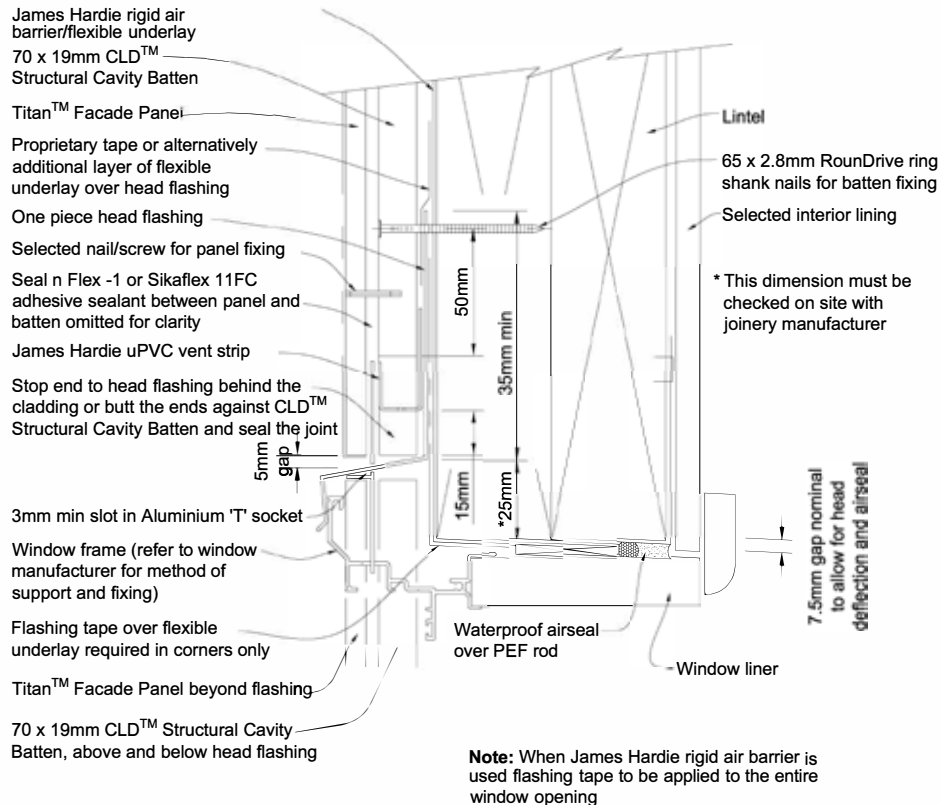

Figure 34: 'T' socket joint at window head

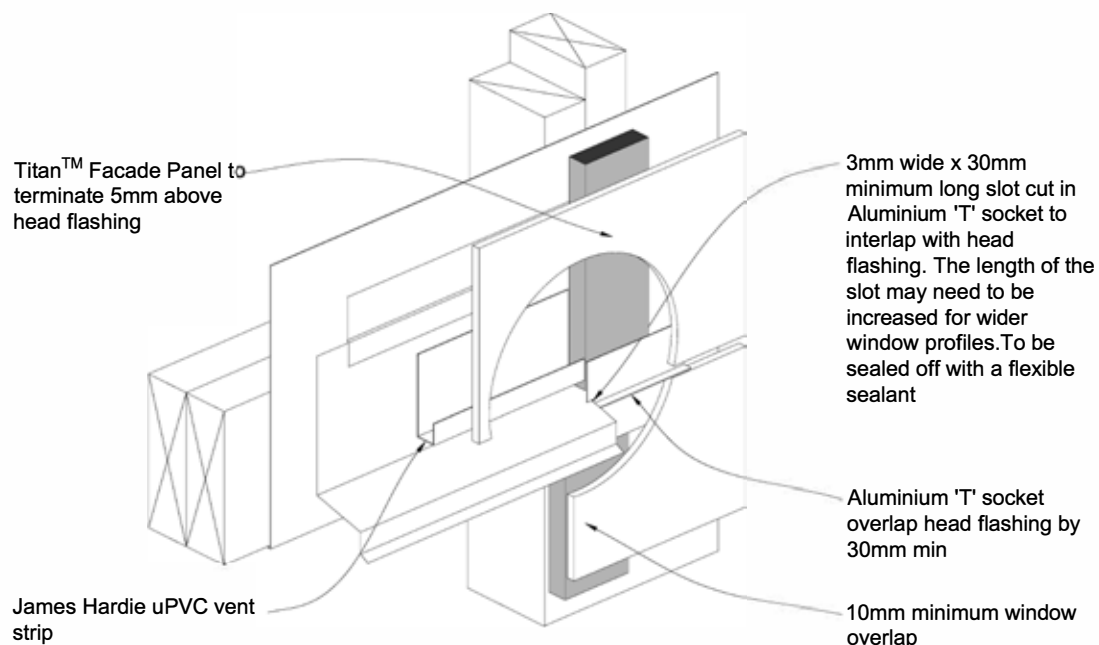
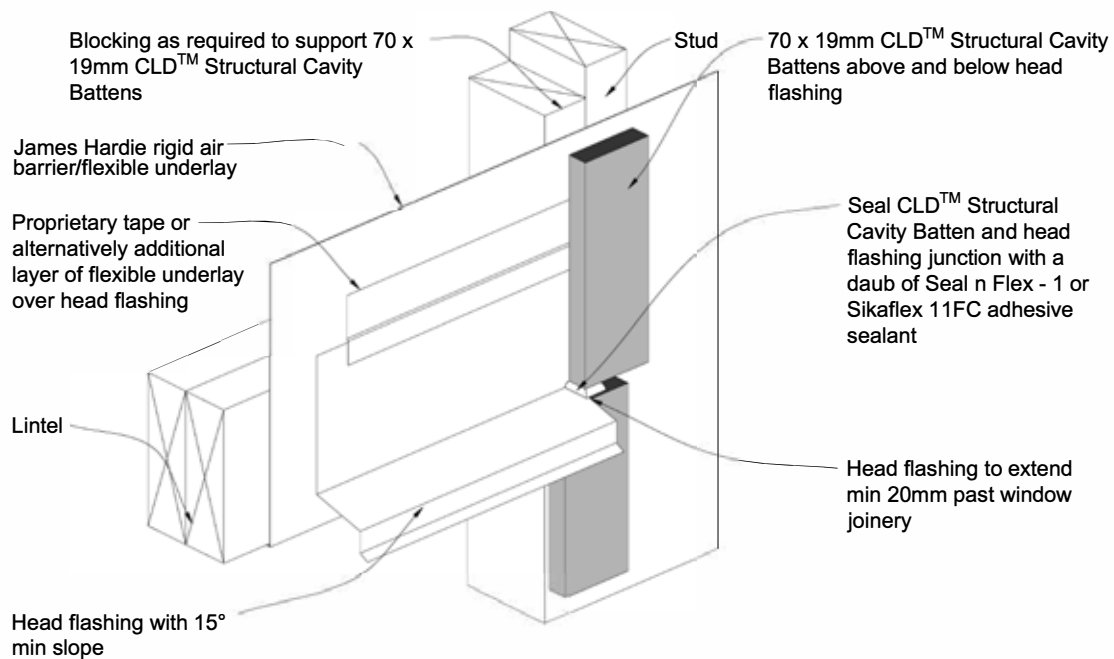

Figure 35: 'T' socket joint at window jamb

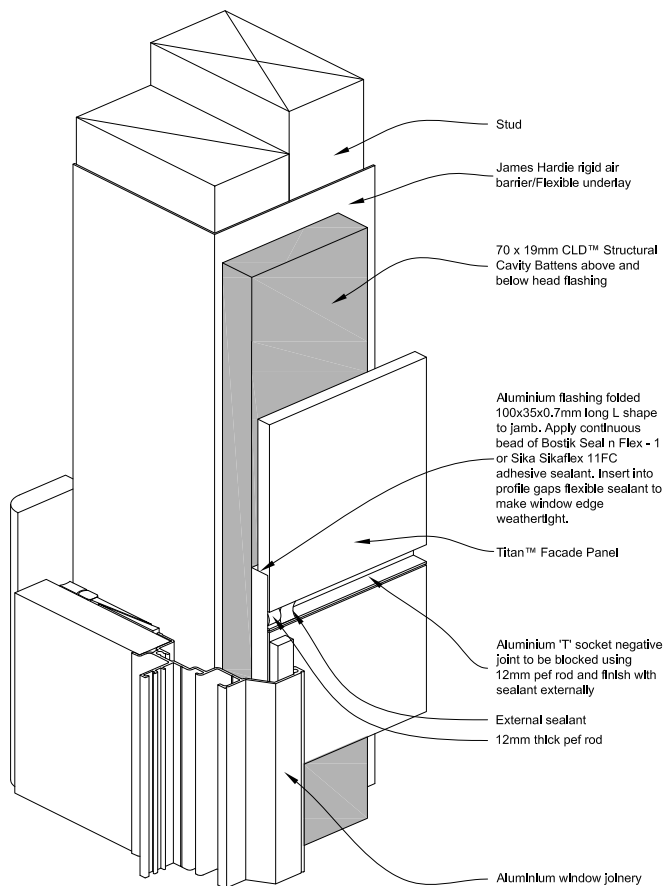

Figure 36: Cavity pipe penetration

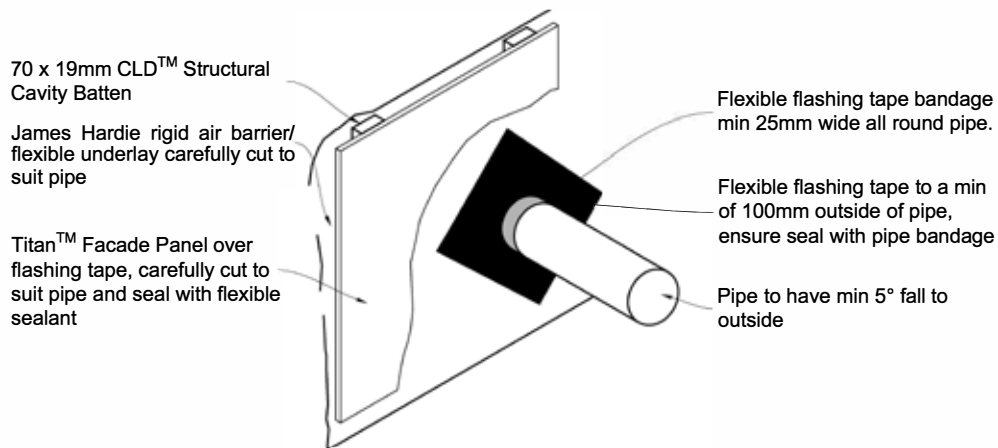
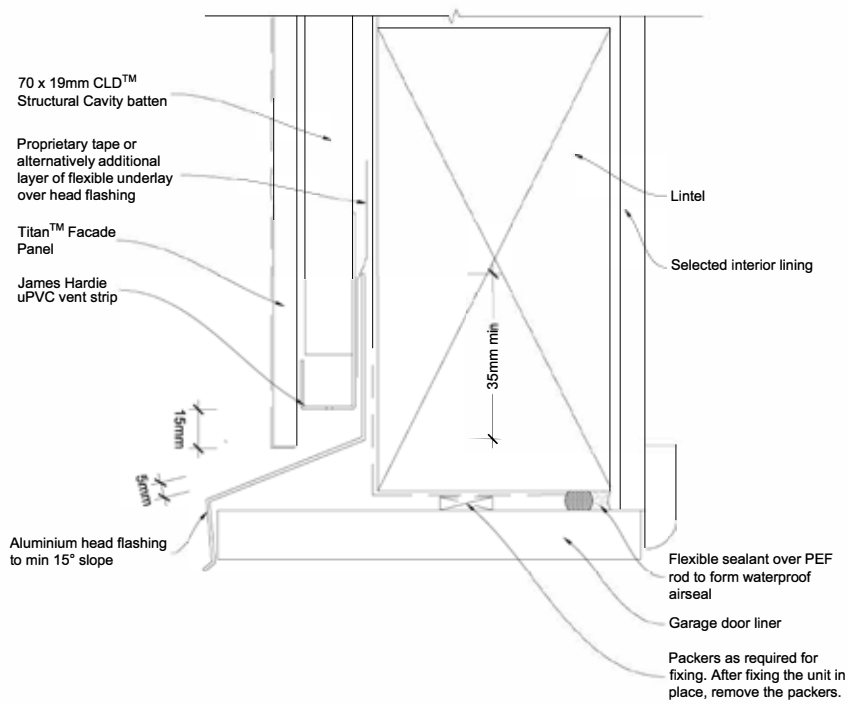

Figure 37: Garage head



Note:

- Sealant must be applied between head flashing and door liner in VH and EH wind zones and SED wind pressures.
- When James Hardie rigid air barrier is used flashing tape to be applied to the entire garage opening.

Figure 38: Garage jamb

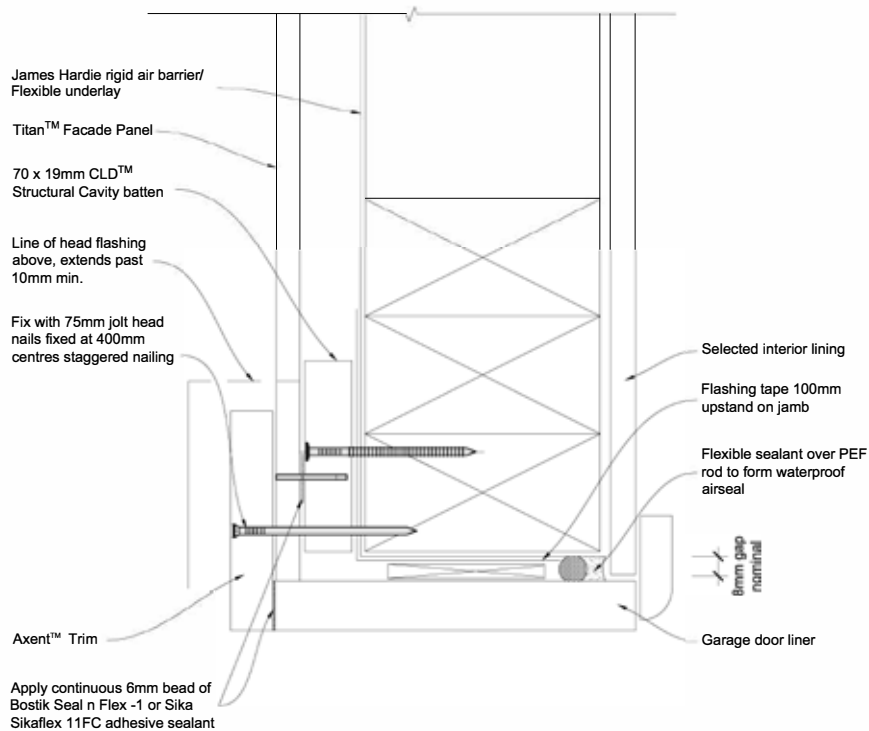

Note:

- When James Hardie rigid air barrier is used flashing tape to be applied to the entire garage opening.

Figure 39: Cavity vertical batten joint

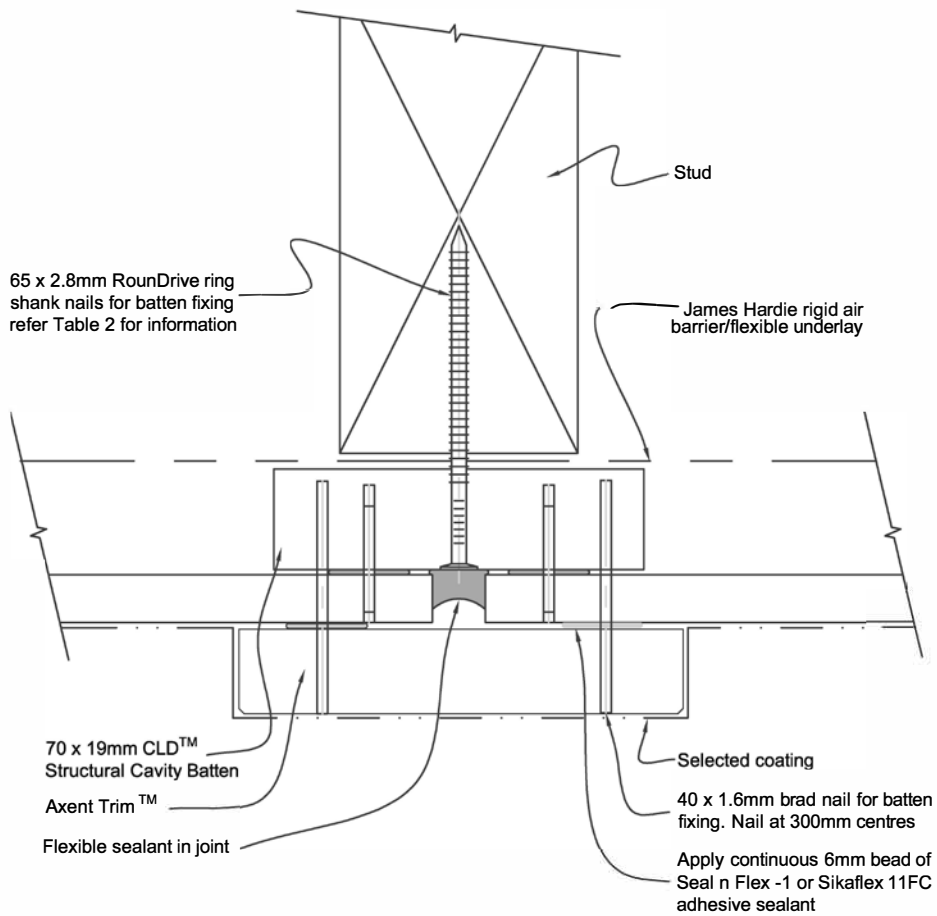
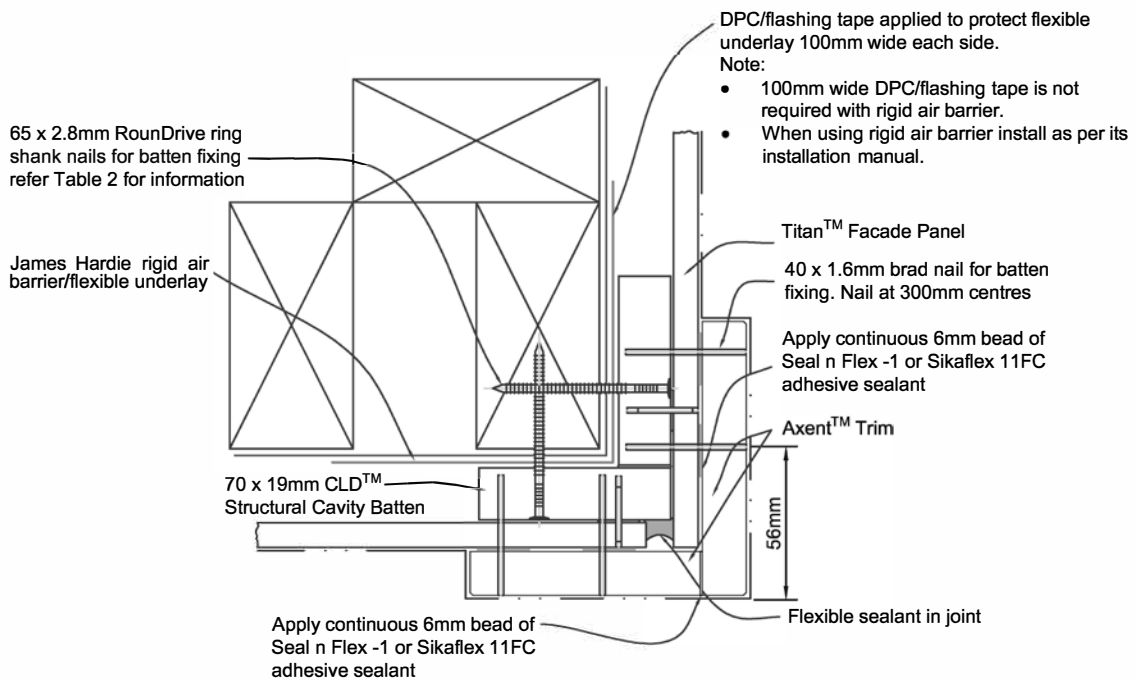

Figure 40: External corner with facings



# Product Warranty



James Hardie New Zealand Limited (“James Hardie”) warrants for a period of 15 years from the date of purchase that the Titan™ Façade Panel, RAB™ Board and CLD™ Structural Cavity Batten (the “Product”), will be free from defects due to defective factory workmanship or materials and, subject to compliance with the conditions below, will be resistant to cracking, rotting, fire and damage from termite attacks to the extent set out in James Hardie’s relevant published literature current at the time of installation. James Hardie warrants for a period of 15 years from the date of purchase that the accessories supplied by James Hardie will be free from defects due to defective factory workmanship or materials.

Nothing in this document shall exclude or modify any legal rights a customer may have under the Consumer Guarantees Act or otherwise which cannot be excluded or modified at law.

## CONDITIONS OF WARRANTY:

The warranty is strictly subject to the following conditions:

- a) James Hardie will not be liable for breach of warranty unless the claimant provides proof of purchase and makes a written claim either within 30 days after the defect would have become reasonably apparent or, if the defect was reasonably apparent prior to installation, then the claim must be made prior to installation;
- b) this warranty is not transferable;
- c) the Product must be installed and maintained strictly in accordance with the relevant James Hardie literature current at the time of installation and must be installed in conjunction with the components or products specified in the literature. Further, all other products, including coating and jointing systems, applied to or used in conjunction with the Product must be applied or installed and maintained strictly in accordance with the relevant manufacturer’s instructions and good trade practice;
- d) the project must be designed and constructed in strict compliance with all relevant provisions of the current New Zealand Building Code (“NZBC”), regulations and standards;
- e) the claimant’s sole remedy for breach of warranty is (at James Hardie’s option) that James Hardie will either supply replacement product, rectify the affected product or pay for the cost of the replacement or rectification of the affected product;
- f) James Hardie will not be liable for any losses or damages (whether direct or indirect) including property damage or personal injury, consequential loss, economic loss or loss of profits, arising in contract or negligence or howsoever arising. Without limiting the foregoing James Hardie will not be liable for any claims, damages or defects arising from or in any way attributable to poor workmanship, poor design or detailing, settlement or structural movement and/or movement of materials to which the Product is attached, incorrect design of the structure, acts of God including but not limited to earthquakes, cyclones, floods or other severe weather conditions or unusual climatic conditions, efflorescence or performance of paint/coatings applied to the Product, normal wear and tear, growth of mould, mildew, fungi, bacteria, or any organism on any Product surface or Product (whether on the exposed or unexposed surfaces);
- g) all warranties, conditions, liabilities and obligations other than those specified in this warranty are excluded to the fullest extent allowed by law;
- h) if meeting a claim under this warranty involves re-coating of Products, there may be slight colour differences between the original and replacement Products due to the effects of weathering and variations in materials over time.

**DISCLAIMER:** The recommendations in James Hardie’s literature are based on good building practice, but are not an exhaustive statement of all relevant information and are subject to conditions (c), (d), (f) and (g) above. James Hardie has tested the performance of the Titan™ Façade Panel, RAB™ Board and CLD™ Structural Cavity Batten when installed in accordance with the Titan™ Façade Panel and CLD™ Cavity Batten technical specification, in accordance with the standards and verification methods required by the NZBC and those test results demonstrate the product complies with the performance criteria established by the NZBC. However, as the successful performance of the relevant system depends on numerous factors outside the control of James Hardie (e.g. quality of workmanship and design) James Hardie shall not be liable for the recommendations made in its literature and the performance of the relevant system, including its suitability for any purpose or ability to satisfy the relevant provisions of the NZBC, regulations and standards, as it is the responsibility of the building designer to ensure that the details and recommendations provided in the relevant James Hardie installation manual are suitable for the intended project and that specific design is conducted where appropriate.

Copyright April 2019. © James Hardie New Zealand Limited. TM and ® denotes a Trademark or Registered Mark owned by James Hardie Technology Limited.

