

Powered by Innovation



Contents



Isolator & Control Switches - 56SW

- 1 Pole – 6 Pole
- 10A – 63A



8



Time Delay Switches - 56TD

- 1 Gang



16



Changeover Switches Forward/Reverse Switches

- 1 Pole – 3 Pole
- 20A – 32A



13



Socket Outlets - 56SO

- 3 Pin – 7 Pin
- 10A – 50A



18



Programmable Time Switches - 56TC

- Quartz
- Digital



14



One Piece Combination Switched Socket Outlets - 56CV

- 3 Pin – 7 Pin
- 10A – 50A



21



Push Buttons - 56PB

- 1 Gang



14



RCD Protected Outlets - 56C/RCD

- 3 Pin
- 10A – 20A



25



Sunset Switch - 56SS10

- 1 Gang



15



Appliance Inlets - 56AI

- 3 Pin – 5 Pin
- 10A – 50A



27



Straight Plugs - 56P
Angled Plugs - 56PA

- 3 Pin - 7 Pin
- 10A - 50A



30



Pendant Enclosures - 56PE

- 2 Gang



39



Pendant Outlets - 56SPO
Cord Connectors - 56CR
Appliance Connectors - 56CSC

- 3 Pin - 5 Pin
- 10A - 50A



32



Flush Surrounds - 56FA

- 1 Gang - 4 Gang



39



DIN Mounting Covers - 56CB

- 4 Pole
- 13 Pole



34



Accessories

- Mounting Feet
- Covers
- Gaskets



40



Enclosures - 56E

- 1 Gang - 16 Gang



36



DOL Motor Starters - 56MS

- 230V
- 400V



41



Lids - 56L

- 1 - 6 Gang
- Module Mounting



38



Technical Section

- Rating Information
- Product Master

46

Powered by innovation

Providing superior user and installer solutions, the iconic 56 Series™ is taken to a new level. New range, new benefits, New Zealand tough.

Since the beginning of the 1980s the 56 Series™ has earned a reputation for top performance in resistance to the harsh treatment of industrial environments.

Introducing the NEW 56 Series™, a range with easier operation, improved strength and integrity, whilst maintaining the 56 Series™ heritage look, and being fully backwards compatible with the old range.

Design Innovation

Several improvements have been made on the existing range through listening to our customers and making their requests a reality.

- Easier switch and socket operation
- Modern contoured profile
- 56 Series™ heritage look & fully backwards compatible
- Reduction of potential dirt build-up areas
- Improved strength and reliability



Patented gasket system

- Two grades of plastic using an over-moulded process
- IP66 without the use of No9 caps
- More rigidity
- Increased integrity of cover to enclosure seal
- Prevents over tightening of the mounting screws



Laser engraved ratings

- The message is permanent and one of quality
- No more silver ratings labels that can fade or fall off
- Switch OFF/ON indicators raised and printed



Socket success

- Easier operation and opens further
- Strengthened hinged flap
- Co-injected flap gasket seal, improves sealing integrity
- More space to access plugs

> What's New



Switches



Socket outlets



Appliance inlets
(10A & 15A)



Combination RCDs



Time switches



Combination
switched sockets



Get the Facts

This new release takes the range to a new level, but the fundamental benefits that make 56 Series™ what it is today remain:

- > **Proven IP66 Protection**
 - Laboratory tested and field proven
- > **Superior Impact Strength**
 - Hi-impact polycarbonate materials used in 56 Series™ are proven and tested to operate in extreme temperatures from -40° to +55°C*
- > **High Level of Switch Performance**
 - Rated up with the best in the business with most switches being motor rated with AC23A and AC3 to IEC60947-3
- > **Specially Formulated Chemical Resistance**
 - In the conditions this range is required to operate, one plastic will not do for all. Resistant orange and white have been developed for environments where harsh chemicals are used
- > **Solvent Bonding Capability**
 - 56 Series™ PVC enclosures are able to be solvent bonded to standard PVC conduit fittings using recommended sealants
- > **Greater UV Resistance**
 - 56 Series™ materials are engineered and proven to provide a higher degree of protection than comparable products
- > **Full Range of Matching Gear**
 - The most comprehensive range available catering for the complete solution, allowing the job to be done properly
- > **Modules Making Assembly Simple**
 - From a single switch or socket, up to a full 16 gang station, the 100x100mm module design allows customer builds and modification to suit a massive range of requirements
- > **Quick, Easy, and Safe Wiring**
 - Designed and engineered with the installer in mind, the 56 Series™ offers many simple and innovative features to assist

*Some products with electronic components do not reach these extremes, these will be listed with the accompanying installation guidelines

Defining Moments in History

- 1981 56 Series™ released to the NZ market with a range of 22 items.
- 1982 Won the prestigious Prince Phillip Award for Industrial Design.
- 1983 Major range expansion with dozens of new items introduced including the one piece combination outlets – 56CV's – by mid-1984 over 300 items in the range.
- 1984 Internationally demanded, PDL Industries in Malaysia producing for British standard markets as well as large export business produced from Christchurch, NZ.
- 1989 Re-rated from IP56 to IP66.
- 1992 Chemically resistant orange 'valox' introduced.
- 1993 Continually adding new product solutions: time switches, RCDs.
- 1999 Chemically resistant white products introduced.
- 2003 Single phase plugs and connectors fully redesigned to meet today's requirements along with more new items including DIN mount covers and boards.
- 2005 Christchurch factory relocates to new premises – the production of over 700 items for the NZ market and over 400 items for international export has new headquarters.
- 2006 Celebrates 25 years.
- 2008 Release of innovative MACTRO™ plugs and connectors in 16A and 20A
- 2009 New Zealand Tough New 56 Series™ release.



Module mount covers



Changeover and reversing switches



Residual current devices



Key-lock switches



LED indication kits

56 Series™ ...Rated No 1!

With features designed to outperform all other protected accessories

Features and benefits with the NEW range...

Fundamental to the range 1981 to now...

Patented co-moulded gasket system
- improved seal integrity

Total IP66 sealing from conduit entry to plug cable

LED technology replacing neons in a field fit kit

Channelled gaskets and high-pressure (HPG) gaskets for extreme environments

Contoured profile
- reducing dust and dirt build-up

Screw caps eliminate dirt

Larger switch for easier operation

LED (formerly neon) indicator option in switches (56SW and 56CV)

Increased padlocking area

Clear indication of switch position

Angled switch handle
- points towards switch position

Padlock ON/OFF facility

Permanent laser engraved ratings
- eliminates stickers and unidentified product

Keylock switch option available in switches (56SW)

Pivot bungs removed
- adds durability

Rotary ON/OFF switch

Socket auxiliary contacts for remote monitoring in a field fit kit

Captive plate screws

Redesigned socket flap
- sockets open 43° further
- 56CV's open 8° further
- increased strength
- more access to plug rings
- 36% less effort to open

Electrical rating and specification are clearly displayed

Available in high impact 'electric grey' or chemically resistant orange and white finishes

Transparent flap clearly shows pin configuration

19 ratings and pin configurations to AS/NZS3123

Plug locking ring maintains IP66 protection while in use

Larger and easier to use latch design
- better grip and operation

Socket cover snaps shut automatically and locks to provide IP66 protection

Modular system for 1 to 16 gang arrangements

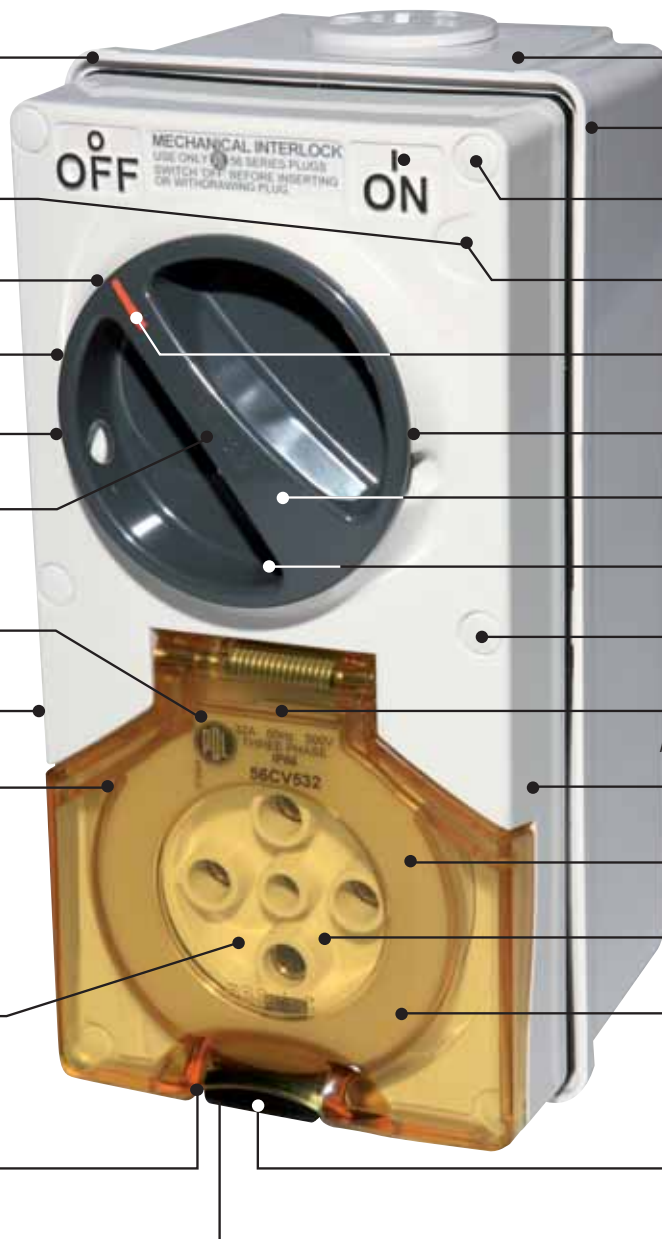



This Edition

INTRODUCING THE NEW 56 SERIES



2009 Release showcased



4 & 6

NEW SUNSET SWITCH



Upgraded module with time-delay and new styling



15 & 17

56 SERIES™ MACTRO™



New plugs and connectors
16A and 20A



28

VERTICAL ENCLOSURE - CAT 56E2V



Increased safety in areas of high traffic by providing the ability for plugs to be flush with the wall



17 & 37

NEW 56 SERIES™ CHEMICAL RESISTANCE CHART



We have re-tested and updated our recommended guidelines

46

Switches to IP66

240V Switches



56 Series™ comprehensive range of 240V Switches ensures that there is always a suitable switch available for every single phase application. They are available in high impact grey and chemically resistant orange and white. Specify GY, RO or RW.

Features	<ul style="list-style-type: none"> • 1 and 2 pole up to 50A • Cover mounted switch mechanisms • Comprehensive switch ratings • IP66 weather protection rating • Dual padlocking points • Patented over-moulded cover gasket
OPTIONS AVAILABLE	
LED Kit	<p>56 Series™ neon switches are now replaced with an LED Kit, suited to all NEW 56 Series™ switches and combination switched socket outlets except changeover and reversing switches.</p> <p>Specify "56LEDK1" for a single red 240V/415V LED Kit</p> <p>Specify "56LEDK3" for a triple red, blue, white 240V/415V LED Kit, suitable for two gang switches only. Refer page 9 for more detail.</p>
Keylock	<p>Specify "K" or "2K" after "56SW" eg: 56SWK220</p> <p>Keylock versions of all PDL switches except the Forward/Reverse, Changeover switches and KG series switches are available.</p> <p>Key removable in the OFF position only – Specify "K" after the series number eg: 56SWK110.</p> <p>Key removable in the OFF and ON positions – Specify "2K" after the series number eg: 56SW2K110.</p> <p>Common keyed switches are available to order for all 56 Series™ Keylock versions – Specify "C" after the series number eg: 56SWKC110.</p>
	<p>Combinations of the above are available.</p> <p>Note: All products are sold less enclosure (LE) as standard.</p>



56SWK110RW



56SW132RW

Cat No		56SW110	56SW110/2	56SW110/2I	56SW210
Rated Operational Voltage Ue (~50Hz)	Volts	240	240	240	240
Rated Thermal Current Enclosed	Amps	10	10	10	10
Wiring Diagram		A	B	C	D
Description		1 way Single Pole	2 way Single Pole	Intermediate Changeover	1 way Double Pole
Cable Cross Sections Solid or Stranded	Min (mm ²) Max (mm ²)	0.75 6	0.75 6	0.75 6	0.75 6
Switch Ratings @ AS/NZS3133 250V M Rating		M50	M50	M40	M40



56LEDK1
See page 9 for detail

Dimensional Drawings

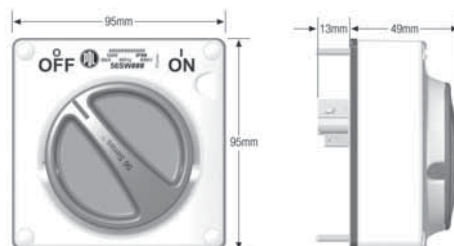

56SW110





240V Switches

Cat No	56SW116	56SW216	56SW120	56SW132	56SW150
Rated Operational Voltage Ue (~50Hz)	Volts 240	240	240	240	240
Rated Thermal Current Enclosed	Amps 16	16	20	32	50
Wiring Diagram	A	D	A	A	A
Description	1 way Single Pole	1 way Double Pole	1 way Single Pole	1 way Single Pole	1 way Single Pole
Switch Disconnector					
Cable Cross Sections Solid or Stranded	Min (mm ²) Max (mm ²) 0.75 6	1 16	1 16	1 16	6 35
Switch Ratings @ AS/NZS3133 250V M Rating	M120	M120	M150	M180	M250
Switch Ratings @ IEC 60947-3					
AC23A 240V	kW 2.2 Amps 15	2.2 15	3.0 21	4.0 28	5.5 35
AC3 240V	kW 1.5 Amps 11	1.5 11	2.2 15	3.0 21	4.0 28



LED Kits for 56 Series™ Switches and Combination Sockets



Field fit LED Kits suited to all NEW 56 Series™ switches and combination switched socket outlets, except change-over and reversing switches. (See image page 8)

Features

- Dual voltage LED 240V/415V
- Field Fit Kit
 - Kit includes: LED on flying leads, lens, o-ring seal, drill bit 5.5mm (7/32), and instructions.

Cat No	56LEDK1	56LEDK3
Rated Operational Voltage Ue (~50Hz)	Volts 240 or 415	240 or 415
Stranded flying leads	22AWG	22AWG
Lens colour	Red	Red, Blue, White
LED life hours	20,000	20,000
Description	Single	Triple



56SW110RW



56SW110GY with 56E2VGY, 56SO310GY

Wiring Diagrams



1 way
Single Pole

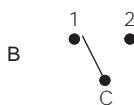

2 way
Single Pole

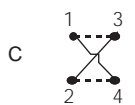

Intermediate
Changeover

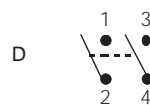

1 way
Double Pole

NOTES:

- AC23A Switching of motor loads or other highly inductive loads.
- AC3 Squirrel-cage motors: switch off motors during running most typical industrial applications.

More info: Page 47

Switches to IP66

415V Switches



All of the 56 Series™ extensive range of 415V Switches are fully motor rated to AC23A and AC3, making them suitable for switching the harshest loads likely to be found in industry. They are available in high impact grey and chemically resistant orange and white. Specify GY, RO or RW.

Features	<ul style="list-style-type: none"> • 3 pole up to 63A • Cover mounted switch mechanisms • Comprehensive switch ratings • Dual padlocking points 	<ul style="list-style-type: none"> • Larger rated items (50A+63A) available in 2 gang cover • IP66 weather protection rating • Patented over-moulded cover gasket
OPTIONS AVAILABLE		
LED Kit	<p>56 Series™ neon switches are now replaced with an LED Kit, suited to all NEW 56 Series™ switches and combination switched socket outlets except change over and reversing switches.</p> <p>Specify "56LEDK1" for a single red 240V/415V LED Kit Specify "56LEDK3" for a triple red, blue, white 240V/415V LED Kit, suitable for two gang switches only. Refer page 9 for more.</p>	
Keylock	<p>Specify "K" or "2K" or "KC" after "56SW" eg: 56SWK332 Refer to page 8 for detail.</p>	
<p>Note: All products are sold less enclosure (LE) as standard.</p>		



56SW3632RO



56SW320GY
and 56LEDK1
(Supplied separately)



56SW332RO

Dimensional Drawings

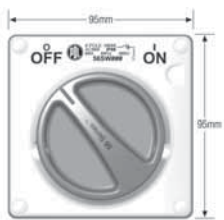

56SW320

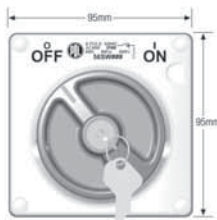

56SWK320

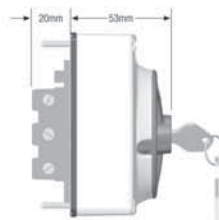

56SW363/2



Wiring Diagrams

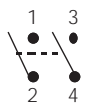

1 way
Double Pole



1 way
Triple Pole

NOTES:

- AC21A Switching of AC Resistive loads, including moderate overloads.
- AC23A Switching of motor loads or other highly inductive loads.
- AC3 Squirrel-cage motors: switch off motors during running most typical industrial applications.
- DC21A Switching of DC Resistive loads, including moderate overloads.

More info: Page 47



415V Switches

Cat No		56SW310	56SW316	56SW220	56SW320	56SW232	56SW332	56SW340	56SW250	56SW350	56SW350/2	56SW363/2
Rated Operational Voltage Ue (~50Hz)	Volts	415	415	415	415	415	415	415	415	415	415	415
Rated Insulation Voltage Ui (~50Hz)	Volts	660	660	660	660	660	660	660	660	660	660	660
Rate Impulse Withstand Voltage Uimp (~50Hz)	kV	2.5	2.5	2.5	2.5	2.5	2.5	2.5	2.5	2.5	2.5	2.5
Rated Thermal Current Enclosed	Amps	10	16	20	20	32	32	40	50	50	50	63
Rated Duty		Uninterrupted	Uninterrupted	Uninterrupted	Uninterrupted	Uninterrupted	Uninterrupted	Uninterrupted	Uninterrupted	Uninterrupted	Uninterrupted	Uninterrupted
Description		3 Pole	3 Pole	1 Way Double Pole	3 Pole	1 Way Double Pole	3 Pole	3 Pole	1 Way Double Pole	3 Pole	3 Pole	3 Pole
Switch Disconnecter												
Cable Cross Section Solid or Stranded mm ²	Min Max	1 16	1 16	1 16	1 16	1 16	1 16	6 35	6 35	6 35	6 35	6 35
Switch Ratings @ AS/NZS3133 500V M Rating		M100	M120	M150	M150	M180	M180	M200	M250	M250	M250	M300
Switch Rating @ IEC60947-3												
AC21A	415V Amps	10	16	20	20	32	32	40	50	50	50	63
AC23A	415V kW Amps	5.5 11	7.5 15	3.0 21	11 21	4.0 28	15 28	18.5 35	5.5 35	18.5 35	18.5 35	22 45
AC3	415V kW Amps	4.0 8.5	5.5 11	2.2 15	7.5 15	3.0 21	11 21	15 28	4.0 28	15 28	15 28	18.5 35
DC21A	32V Amps	10	16		20		32	40		50	50	63
Rated Short Time Withstand Current 1 second	kA	1.5	1.5	1.5	1.5	1.5	1.5	1.5	1.5	1.5	1.5	1.5
Rated Short Circuit Making Capacity	kAp	1.0	1.0	1.0	1.0	1.0	1.0	2.1	2.1	2.1	2.1	2.1

Auxiliary Contacts for 56SW350/2 and 56SW363/2



Two clip-on auxiliary contacts suitable for use with the 56SW350/2 and 56SW363/2. Both auxiliaries are easily clipped to the top of the switches and are suitable for control applications

Features

- Clip-on auxiliaries cover both LV and ELV applications

Cat No		56SW01	56SW15
Rated Operational Voltage Ue (~50Hz)	Volts	125 or 250	250
Rated Thermal Current Enclosed	Amps	0.1 at 125V 0.05 at 250V	15
Terminal Type		Screw	Screw
Description		Single Pole	Single Pole
Contacts		1 N/O & 1 N/C	1 N/O & 1 N/C
Contact Type		Gold	Nickel/Silver
Switch Ratings @ BS3676 250V Fluorescent		8AX	8AX

500V KG Switches - IP66

500V KG Switches



The 56 Series™ has utilised the proven Kraus and Naimer KG Series of switches in this range of 56 Series™ switches. 56SW320/KG and 56SW332/KG suit 56E1 enclosures, 56SW340/KG and 56SW363/KG require a 56E2 enclosure to provide adequate wiring room. Specialist genuine 4 and 6 pole switches available.

They are available in high impact grey and chemically resistant orange and white. Specify GY, RO or RW.

Note

- KG switches are not available in KEYLOCK versions
- Both 56SW420KG and 56SW432KG are available to suit 56E1 and 56E2 enclosures
- To order specify 56SW4##/2KG for a 56E2 enclosure
- All products are sold less enclosure (LE) as standard



56SW420KGRO



56SW432KGGY

Cat No		56SW320KG	56SW332KG	56SW340KG	56SW363KG	56SW420KG	56SW432KG	56SW620KG	
Rated Operational Voltage Ue (~50Hz)	Volts	500	500	500	500	500	500	500	
Rated Insulation Voltage Ui (~50Hz)	Volts	690	690	690	690	690	690	690	
Rated Thermal Current Enclosed	Amps	20	32	40	63	20	32	20	
Wiring Diagram		A	A	A	A	B	B	C	
Cable Cross Section Solid or Stranded mm ²	Min Max	1 6	1 6	1.5 16	1.5 16	1 6	1 6	1 2 x 2.5	
Switch Rating @ IEC60947-3									
AC21A	415V	Amps	20	32	40	63	20	32	20
AC23A	415V	kW	7.5	11	15	22	7.5	11	7.5
		Amps	15	21	28	45	21	21	14
AC3	415V	kW	5.5	7.5	11	18.5	5.5	7.5	5.5
		Amps	11	15	21	35	11	15	11
DC22A	115V	Amps	16	25	32	-	16	25	16
Max. Fuse Size	Amps	35	35	50	80	35	35	25	
Rated Short Time Withstand Current 1 Second	Amps	350	430	500	950	350	430	140	
Rated Short Circuit Making Capacity	kAp	2.2	2.2	5	5	2.2	2.2	2.2	

Dimensional Drawings

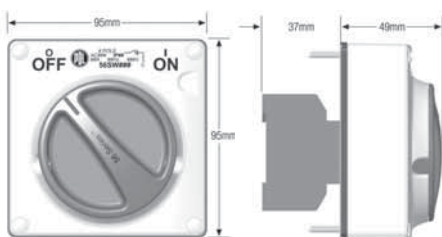

56SW332KG

Wiring Diagrams



3 Pole



4 Pole



6 Pole



Control Switches - IP66

Changeover and Forward/Reverse Switches IP66



A range of IP66 Changeover and Forward/Reverse switches ideal for generators, auto/manual systems, fans, doors and conveyors. Each switch comes with a sheet of adhesive labels for the end user to select the appropriate cover markings for the specific application. Cover markings possible include:

I, II FWD, REV MAN, AUTO
 AUX, MAIN UP, DOWN

Control Switches are supplied as a standard 100 x 100 one gang module less enclosure.

Features	<ul style="list-style-type: none"> • IP66 rated • Comprehensive switch ratings
Note	<ul style="list-style-type: none"> • Grey (GY), orange (RO), and white (RW) available • All products are sold less enclosure (LE) as standard • Not suitable for LED Kit



56SW320FRRO



56SW320COGY

NOTES:

- AC21A Switching of AC Resistive loads, including moderate overloads.
 - AC23A Switching of motor loads or other highly inductive loads.
 - AC3 Squirrel-cage motors: switch off motors during running most typical industrial applications.
 - AC4 Squirrel-cage motors: including reversing, plugging and inching.
 - DC21A Switching of DC Resistive loads, including moderate overloads.
 - DC22A Switching of inductive DC loads.
- More info: Page 47

Cat No	56SW120CO	56SW320CO	56SW332CO	56SW320FR
Rated Operational Voltage Ue (~50Hz)	Volts	500	500	500
Rated Insulation Voltage Ui (~50Hz)	Volts	690	690	690
Rated Thermal Current Enclosed	Amps	20	20	32
Description		1 Pole Changeover	3 Pole Changeover	3 Pole Reversing
Wiring Diagram		A	B	C
Cable Cross Section Solid or Stranded	mm ²	2 x 2.5	2 x 2.5	2 x 6
Switch Rating @ IEC60947-3				
AC21A	500V	Amps	20	20
AC23A	415V	3 Phase	kW	-
	240V	1 Phase	kW	2.5
AC3	415V	3 Phase	kW	-
	240V	1 Phase	kW	2.2
AC4	415V	3 Phase	kW	-
	240V	1 Phase	kW	0.75
DC21A	24V	Amps	20	20
DC22A	24V	Amps	12	12
Max. Fuse Size	Amps	25	25	35
Rated Short Time Withstand Current 1 Second	Amps	140	140	480
Rated Short Circuit Making Capacity	kAp	5	5	5

Dimensional Drawings

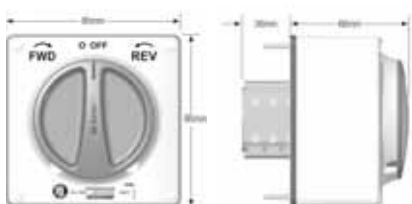

56SW320FR & 56SW320CO

Wiring Diagrams



Single Pole Changeover Switch, Double Throw with Centre Off

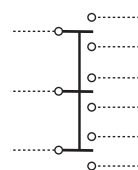

Triple Pole Changeover Switch, Double Throw with Centre Off

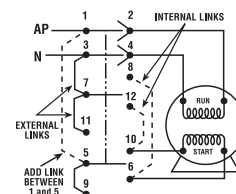

Single Phase Reversing

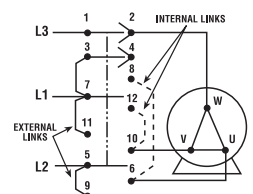

Three Phase Reversing

Time Switches - IP66

Momentary Contact Switches - IP66

Time Switches - IP66



56 Series™ Time Switches feature 24 hour and 7 day timers for the automatic time switching of process control equipment, heaters, pumps and lighting in domestic, commercial and industrial situations.

These timers are supplied in a standard 1 gang 56 Series™ cover for use with 56 Series™ deep enclosures. Supplied with a padlocking clip to enable the flap to be locked closed.



56TCU



56TC24HBRO

Cat No	56TC24HB	56TC7DB	56TCU
Description	24 Hour Quartz	7 Day Quartz	24 Hour and 7 Day Digital
Rated Operational Voltage Ue (-50Hz)	Volts 230 – 240	230 – 240	230 – 240
Switching Capacity			
Maximum Resistive	Amps 16	16	16
Maximum Inductive	Amps 8	8	2.5
Maximum Incandescent	Watts 1350	1350	1000
Minimum Switching Load	mA 100	100	100
Accuracy	± 2.5 Sec Per Day	± 2.5 Sec Per Day	± 2.5 Sec Per Day
Running Reserve	150 Hours	150 Hours	150 Hours
Minimum Switching Time	15 Minutes	2 Hours	1 Minute
Programming Spaces	-	-	42 (21 on/21 off)
Cable Cross Section Solid or Stranded mm ²	Min 0.75 Max 6	0.75 6	0.75 6

Momentary Contact Switches - IP66



56 Series™ push button switches can be used for remote switching of control gear or motor starters. These switches are supplied in a standard 56 Series™ one gang cover for use with 56 Series™ enclosures.



56PB2GRGY

Cat No	56PB1/G	56PB1/R	56PB2G/R
Rated Operational Voltage Ue (-50Hz)	Volts 250	250	250
Rated Thermal Current Enclosed	Amps 16	16	16
Push Button Colour	1 x Green	1 x Red	1x Green, 1 x Red
Cover Markings			Start/Stop
Cable Cross Section Solid or Stranded mm ²	Min 0.75 Max 6	0.75 6	0.75 6
Utilisation Category Feed Control of Contactors Electro-Magnets and Valves			
AC11 250V	Amps 4	4	4
415V	Amps 2	2	2
Cable Cross Section Solid or Stranded mm ²	Min 0.75 Max 6	0.75 6	0.75 6

Wiring Diagrams

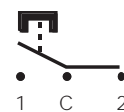

1 N/O and 1 N/C
Momentary Contact
Push Button

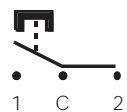

2 N/O and 2 N/C
Momentary Contact
Push Button



Sunset Switch - IP66

Dimensional Drawings

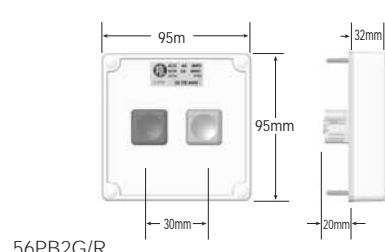
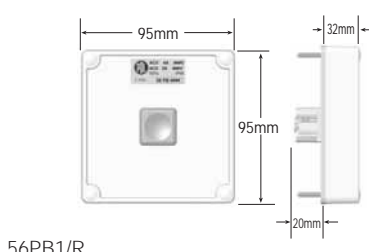
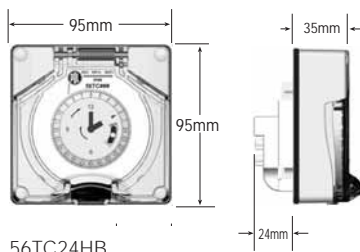

56TC24HB

56PB1/R

56PB2G/R

Sunset Switch



These photoelectric cell light sensors are designed to switch a load on at dusk and off at dawn. They are ideal for outdoor lighting, pool timers, water features, entry and security applications, building management, and community control applications. They have built-in time delays to reduce nuisance switching from brief exposure to lights or shadows.

Set up and installation is made easy with an installer selectable timer, with the ability to control delay off or permanently on functions at the turn of a dial. It has a built-in bi-colour LED for switching identification, and comes supplied with a black daylight test over.

The product is either supplied with a shallow enclosure (56SS10WE) or less enclosure (56SS10) for use with any 56 Series™ enclosure combination. Available opal only.



56SS10WE



The 56 Series™ IP66 Sunset Switch has undergone an upgrade, which includes improved ratings, better installation features, and a new look matching the release of the switches and socket outlets.

Cat No		56SS10	
Rated Operational Voltage Ue (~50Hz)	Volts	240	
Switching Capacity		Amps	Watts
Maximum Resistive		10	2400
Maximum Incandescent		10	2400
Maximum Halogen		8	2000
Maximum Inductive		6	1500
Maximum Fluorescent		6	1500
Maximum Compact Fluorescent		1	240
Switching Light Level (Lux)		Factory Preset to 50 Lux with calibration dial adjustment 20 to 100 Lux	
Timer		6 position: ON, Dusk to Dawn, 2H, 4H, 6H, 8H	
Bicolour LED		Green - power Red - daylight switch/timer operating	
Cable Cross Sections Solid or Stranded mm ²	Min Max	0.75 6	
Operating Temp	degC	-10 to 45	
IP Rating		IP66	

Dimensional Drawings



56SS10

Time Delay - IP66



Time Delay - IP66



56 Series™ Time Delay allows a load to be switched for a preset time interval. Ideal for controlling lighting and heating in commercial and industrial situations. Time Delay is supplied in a standard 1 gang cover for use with any 56 Series™ enclosure combination.

The old 56 Series™ preset countdown timers have been superseded by the new modular time delay device. The 648TM fits the 56 Series™ module mounting covers and can be installer preset to suit the application.

56TD available grey (GY) only.



56TD



56MO500/1 with 648TM

Cat No		56TD	648TM*
Description		Adjustable electronic time delay for switching load for a preset time	Preset Countdown Timer
Rated Operational Voltage (~50Hz)	Volts	230 – 240	230 – 240
Switching Capacity			
Maximum Resistive	Amps	10	3
Maximum Incandescent	Watts	2000	
Maximum Inductive	Amps	6	
Time Selection Range		1 second to 31.5 hours	15 seconds to 120 minutes
Push Button Colour		Blue	Silver
LED Indicator		-	Blue
Cable Cross Section	Min	0.75	-
Solid or Stranded mm ²	Max	6	-

* Fits to 56MO500 module mounting covers and can be used with the 600RM relay module to obtain up to 16A resistive load.



Dimensional Drawings

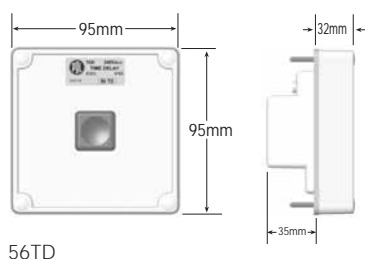

56TD

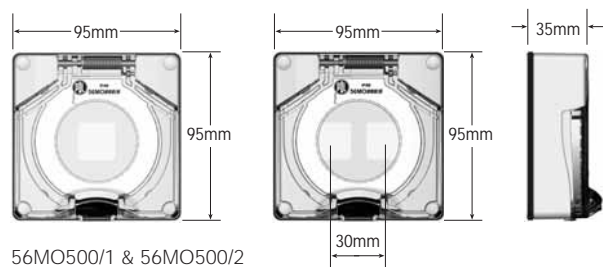

56MO500/1 & 56MO500/2

Think outside the box and standardise on safety

- > The innovative 56 Series™ mounting enclosure that allows plugs to sit flush with the wall
- > Improved safety in high-traffic and hazardous areas
- > Fits any two single-gang 56 Series™ products
- > Specify the Cat 56E2V vertical enclosure into your electrical installation



For further information, please contact Customer Care on 0800 652 999 or visit www.pdl.co.nz

Schneider
Electric

At the end of the day... 56 Series™ was the winner

- The upgraded 56 Series™ Sunset Switch
- Improved performance
- Better ratings
- Enhanced installer and user options
- Introduced November 2009

New ratings: 10A resistive,
8A halogen, 6A inductive, 6A fluorescent,
240W compact fluorescent



For further information, please contact Customer Care on 0800 652 999 or visit www.pdl.co.nz

Schneider
Electric

Socket Outlets - IP66

110 - 250V Socket Outlets



56 Series™ 110 – 250V Socket Outlets feature a transparent hinged flap which snaps shut and locks over the socket when the plug is withdrawn, forming an automatic IP66 seal. The flap is transparent so the pin configuration can be readily identified without opening.

They are available in high impact grey and chemically resistant orange and white. Specify GY, RO or RW.

Note: All products are sold less enclosure (LE) as standard.



56SO310RW



56SO310/2RO



56SO316240GY

Cat No		56SO310	56SO310/2	56SO310R	56SO310A	56SO315	56SO315A	56SO320F
Rated Operational Voltage Ue (-50Hz)	Volts	250	250	250	250	250	250	250
Rated Thermal Current Enclosed	Amps	10	10	10	10	15	15	20
Number of Socket Pins (Including Earth ⊕)		3 (Flat)	3 (Flat)	3 (2 Flat & Round Earth)	3 (Flat)	3 (Flat)	3 (Flat)	3 (Flat)
Description		NZ/Aust	NZ/Aust Twin Socket	NZ/Aust Round Earth	NZ/Aust Auto Switched Double Pole	NZ/Aust	NZ/Aust Auto Switched Double Pole	NZ/Aust 3 Large Flat Pin
Socket Configuration refer Pg 55		A	A	B	A	D	D	E
Cable Cross Sections Solid or Stranded mm ²	Min Max	0.75 10	0.75 10	0.75 10	0.75 10	0.75 10	0.75 10	0.75 10
IP Rating		IP66	IP66	IP66	IP66	IP66	IP66	IP66

Cat No		56SO316/110	56SO316/240	56SO320	56SO332
Rated Operational Voltage Ue (-50Hz)	Volts	110 Yellow	230 Blue	250	250
Rated Thermal Current Enclosed	Amps	16	16	20	32
Number of Socket Pins (Including Earth ⊕)		3 (Round)	3 (Round)	3 (Round)	3 (Round)
Description		CEE17 - 4h	CEE17 - 6h	AS/NZS3123	AS/NZS3123
Socket Configuration refer Pg 55		V	W	F	G
Cable Cross Sections Solid or Stranded mm ²	Min Max	0.75 6	0.75 6	1.0 10	1.0 16
IP Rating		IP66	IP66	IP66	IP66

Dimensional Drawings

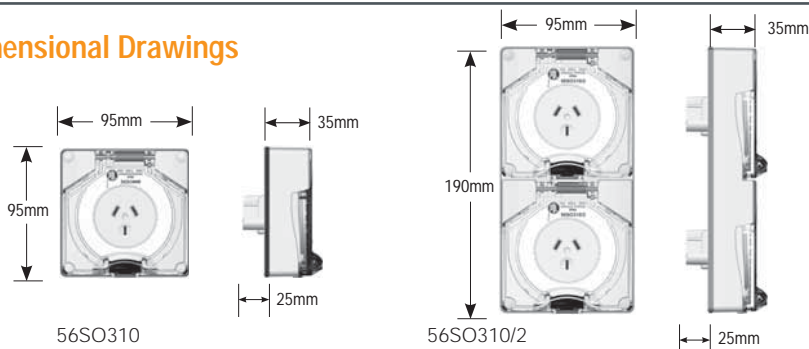

NOTES:

For pin configurations refer to inside back cover – 56 Series™ Product Master – Page 55



500V Socket Outlets



Socket units are supplied as a standard 100 x 100 one gang module for use with 56E1 enclosures or combining with other accessories in a larger enclosure. They are available in high impact grey and chemically resistant orange and white as standard. Specify GY, RO or RW.

Note: All products are sold less enclosure (LE) as standard.

Cat No		56S0416	56S0416K*	56S0420	56S0432	56S0440	56S0450
Rated Operational Voltage Ue (~50Hz)	Volts	500	500	500	500	500	500
Rated Thermal Current Enclosed	Amps	16	16	20	32	40	50
Number of Socket Pins (Including Earth ⊕)		4	4	4	4	4	4
Socket Configuration refer Pg 51		H	I	J	K	L	M
Cable Cross Section Solid or Stranded mm ²	Min Max	1 10	1 10	1 10	1 16	1 16	4 25
IP Rating		IP66	IP66	IP66	IP66	IP66	IP66

* Special keyway for dedicated applications

Cat No		56S0516	56S0520	56S0532	56S0540	56S0550	56S0616	56S0716	56S0720
Rated Operational Voltage Ue (~50Hz)	Volts	500	500	500	500	500	500	500	500
Rated Thermal Current Enclosed	Amps	16	20	32	40	50	16	16	20
Number of Socket Pins (Including Earth ⊕)		5	5	5	5	5	6	7	7
Socket Configuration refer Pg 55		N	O	P	Q	R	S	T	U
Cable Cross Section Solid or Stranded mm ²	Min Max	1 10	1 10	1 16	1 16	4 25	1 10	1 10	1 10
IP Rating		IP66	IP66	IP66	IP66	IP66	IP66	IP66	IP66



56S0450RO and 56SOLOCK
(Note: Padlock not supplied)



56S0716RO



56S0550GY rear with 56SOAUX15
(Supplied separately)

NOTES:

For pin configurations refer to inside back cover – 56 Series™ Product Master – Page 55



Socket Auxiliary Switch Contact



Field fit with the ability to fit to any NEW 56 Series™ socket outlet 16A and above (except CEE sockets), and combination switched sockets 32A and above. Provides indication of socket status for monitoring purposes. Supplied with mounting bracket, fixing screw, and activator. Late make/early break operation.

Cat No		56SOAUX15
Rated Operational Voltage Ue (~50Hz)	Volts	250
Rated Thermal Current Enclosed	Amps	15
Terminal Type		Screw
Description		Single Pole
Contacts		1 N/O & 1 N/C
Contact Type		Nickel/Silver

Dimensional Drawings

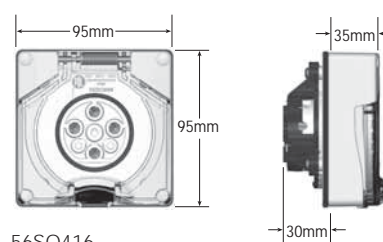

56S0416

CEE17 Socket Outlets - IP57

CEE17 Socket Outlets



Where socket outlets to the European CEE17 standard are required, the 56 Series™ CEE sockets are available and suit standard 56 Series™ enclosures. Where a 56 Series™ CEE socket requires a 56 Series™ switch, they should be fitted to a horizontally mounted 56E2 enclosure. They are available in grey (GY) only.

Note: All products are sold less enclosure (LE) as standard.

Cat No		56S0316 CEE	56S0332 CEE	56S0416 CEE	56S0432 CEE	56S0432C CEE*	56S0516 CEE	56S0532 CEE
Rated Operational Voltage Ue (-50Hz)	Volts	230	230	400	400	400	400	400
Rated Thermal Current Enclosed	Amps	16	32	16	32	32	16	32
Number of Socket Pins (Including Earth Ⓧ)		3	3	4	4	4	5	5
Socket Configuration refer Pg 55		W	X	Y	Z	Aa	Bb	Cc
Earth Pin Position		6H	6H	6H	6H	3H	6H	6H
Frequency Colour		Blue	Blue	Red	Red	Red	Red	Red
Cable Cross Section Solid or Stranded mm ²	Min Max	1.5 4	2.5 10	1.5 4	2.5 10	2.5 10	1.5 4	2.5 10
IP Rating		IP57	IP57	IP57	IP57	IP57	IP57	IP57
Matching Plug		BALS21238	BALS21240	BALS21349	BALS21351	BALS21485	BALS21239	BALS21241

* 56S0432C CEE specifically for international container equipment.



56S0432 CEE



56S0432C CEE



Dimensional Drawings

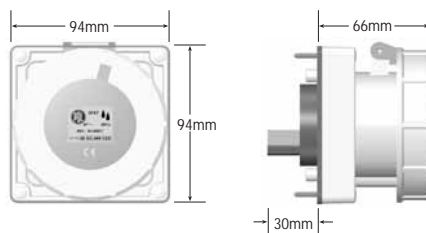

56S0432 CEE



Combination Switched Sockets - IP66

250V Combination Switched Sockets



The 56 Series™ includes an extensive range of one piece combination Switched Sockets.

They are available in high impact grey, and chemically resistant orange and white as standard. Specify GY, RO or RW.

Features	<ul style="list-style-type: none"> • One piece products, clean lines, minimises dirt traps • Self-locking clear socket flap • Patented over moulded cover gaskets • IP66 weather protection rating • Dual padlocking points • Provision for LED indication
Note	<ul style="list-style-type: none"> • For keylocking products, please use 56 Series™ switches • All products are sold less enclosure (LE) as standard



56CV310RW and 56LEDK1
(Supplied separately)



56CV420GY
and 56PA420QC
(refer 500V page 23)

Cat No		56CV310	56CV315
Rated Operational Voltage Ue (-50Hz)	Volts	250	250
Rated Thermal Current Enclosed	Amps	10	15
Description		Switched NZ/Aust. Socket	Switched NZ/Aust. Socket
SWITCH Description		1 way Single Pole	1 way Double Pole
Switch Rating @ AS/NZS3133 0.4 pf inductive 250V M Rating		10AX M50	16AX M120
Switch Rating @ IEC60947-3 AC23A 240V	kW Amps	2.2 15	2.2 15
Cable Cross Section Solid or Stranded mm ²	Min Max	0.75 6	1.0 16
SOCKET Number of Socket Pins Including (Earth ⊕)		3 (Flat)	3 (Flat)
Socket Configuration - Refer Pg 55		A	D
Cable Cross Section Solid or Stranded mm ²	Min Max	1.0 10	1.0 10
IP Rating		IP66	IP66

Dimensional Drawings

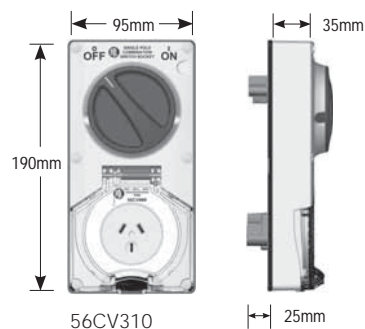

NOTES:

For pin configurations refer to inside back cover – 56 Series™ Product Master – Page 55

AC23A Switch of motor loads or other highly inductive loads.

More info: Page 47

Combination Switched Sockets - IP66

250V Combination Switched Sockets

Features

- One piece products, clean lines, minimises dirt traps
- Self-locking clear socket flap
- Patented over-moulded cover gaskets
- IP66 weather protection rating
- Dual padlocking points
- Provision for LED indication
- Provision for a socket auxiliary contact (32A and above)
- refer page 19 for details



56CV316240GY



56CV416RO (refer 500V page 23)



56LEDK1 (refer page 9)

Cat No		56CV316/240	56CV320	56CV332
Rated Operational Voltage Ue (~50Hz)	Volts	240	250	250
Rated Thermal Current Enclosed	Amps	16	20	32
Description		Switched CEE17-6h Socket (Blue)	Switched AS3123 Socket	Switched AS3123 Socket
SWITCH Description		1 way Double Pole	1 way Double Pole	1 way Double Pole
Switch Rating @ AS/NZS3133 0.4 pf inductive 250V M Rating		16AX M120	20AX M150	32AX M150
Switch Rating @ IEC60947-3				
AC23A 240V	kW Amps	2.2 15	3.0 21	4.0 28
AC3 240V	kW Amps	5.5 11	7.5 15	11 21
Cable Cross Section Solid or Stranded mm ²	Min Max	1.0 16	1.0 16	1.0 16
SOCKET Number of Socket Pins Including (Earth ⊕)		3 (Round)	3 (Round)	3 (Round)
Socket Configuration - Refer Pg 55		W	F	G
Cable Cross Section Solid or stranded mm ²	Min Max	1.0 6	1.0 10	1.0 16
IP Rating		IP66	IP66	IP66

Dimensional Drawings

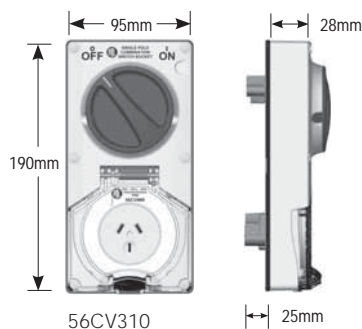

56CV310

NOTES:

For pin configurations refer to
inside back cover - 56 Series™
Product Master - Page 55



500V Combination Switched Sockets



All 500V Switched Sockets rated 32A and above have an internal interlocking feature (plugs cannot be withdrawn or inserted when the switch is in the ON position) with this feature available on 16A and 20A units on request. The 56CV 3, 4 and 5 pin units of 16A and 20A rating (except CEE17 style) have a one piece, internally wired base. This results in faster and tidier installation from having more space and less terminals to check. For keylocking products please use 56 Series™ switches.

Features	<ul style="list-style-type: none"> • One piece products, clean lines, minimises dirt traps • Self-locking clear socket flap • Patented over-moulded cover gaskets • Safety interlock feature (32A + above) • 16A and 20A with one piece, internally wired, switch and socket base • IP66 weather protection rating • Dual padlocking points
Available	Available in high impact grey and chemically resistant orange and white. Specify GY, RO or RW.
Note	All products are sold less enclosure (LE) as standard.



56CV532RW

Cat No		56CV416	56CV420	56CV432	56CV440	56CV450
Rated Operational Voltage Ue (~50Hz)	Volts	500	500	500	500	500
Rated Thermal Current Enclosed	Amps	16	20	32	40	50
SWITCH Description		3 Pole	3 Pole	3 Pole	3 Pole	3 Pole
Switch Rating @ AS/NZS3133 0.4 pf inductive 250V M Rating		16AX M120	20AX M150	32AX M180	50AX M250	50AX M250
Switch Rating @ IEC60947-3						
AC23A 415V	kW Amps	7.5 15	11.0 21	15.0 28	18.5 35	18.5 35
AC3 415V	kW Amps	5.5 11	7.5 15	11 21	15 28	15 28
Cable Cross Sections Solid or Stranded mm ²	Min Max	1 16	1 16	1 16	6 35	6 35
SOCKET Number of Socket Pins (Including Earth ⊕)		4	4	4	4	4
Socket Configuration - Refer Pg 55		H	J	K	L	M
Cable Cross Section Solid or stranded mm ²	Min Max	1.0 10	1.0 10	1.0 16	1.0 16	6.0 25
IP Rating		IP66	IP66	IP66	IP66	IP66



Interlock feature (seen from rear)

Dimensional Drawings

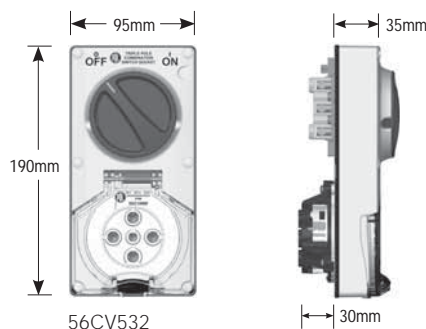

NOTES:

- AC23A Switching of motor loads or other highly inductive loads.
- AC3 Squirrel-cage motors: switch off motors during running most typical industrial applications

More info: Page 47

Combination Switched Sockets - IP66

500V Combination Switched Sockets - continued

Cat No		56CV516	56CV520	56CV532	56CV540	56CV550	56CV616	56CV716	56CV720
Rated Operational Voltage Ue (-50Hz)	Volts	500	500	500	500	500	500	500	500
Rated Thermal Current Enclosed	Amps	16	20	32	40	50	16	16	20
SWITCH Description		3 Pole	3 Pole	3 Pole	3 Pole	3 Pole	3 Pole	3 Pole	3 Pole
Switch Rating @ AS/NZS3133 0.4 pf inductive 500V M Rating		16AX M120	20AX M150	32AX M180	50AX M250	50AX M250	16AX M120	16AX M120	20AX M150
Switch Rating @ IEC60947-3									
AC23A 415V	kW Amps	7.5 15	11.0 21	15.0 28	18.5 35	18.5 35	7.5 15	7.5 15	11.0 21
AC3 415V	kW Amps	5.5 11	7.5 15	11 21	15 28	15 28	5.5 11	5.5 11	7.5 15
Cable Cross Sections Solid or Stranded mm ²	Min Max	1 16	1 16	1 16	6 35	6 35	1 16	1 16	1 16
SOCKET Number of Socket Pins (Including Earth ⊕)		5	5	5	5	5	6	7	7
Socket Configuration refer Pg 55		N	O	P	Q	R	S	T	U
Cable Cross Section Solid or stranded mm ²	Min Max	1.0 10	1.0 10	1.0 16	1.0 16	6.0 25	1.0 10	1.0 10	1.0 10
IP Rating		IP66	IP66	IP66	IP66	IP66	IP66	IP66	IP66



Wiring Diagrams

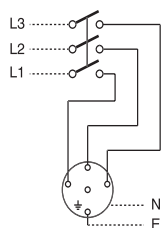
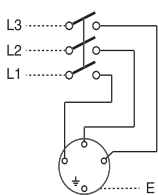

ALL SOCKETS VIEWED
FROM FRONT

--- EXTERNAL
CONNECTIONS BY
CUSTOMER

— INTERNAL
CONNECTIONS

NOTES:

- AC23A Switching of motor loads or other highly inductive loads.
- AC3 Squirrel-cage motors: switch off motors during running most typical industrial applications

More info: Page 47



RCD Protected Outlets - IP66

RCD Protected Outlets - IP66



56 Series™ RCD protected socket outlets protect the user against an earth fault. They feature double pole switching and respond to earth fault in pulsating DC applications. 56 Series™ RCDs are available with both latching and non-latching RCD modules.

To order a non-latching product specify 'A' in the description (ie. 56ARCD20).

To order a latching product refer to the descriptions below.

Features	<ul style="list-style-type: none"> • 30mA rated tripping current for personal protection • IP66 weather protection rating • Self-locking cover flap • Double pole switching • Power consumption 16W at 240V
Available	Available in high impact grey and chemically resistant orange and white. Specify GY, RO or RW.
Note	All products are sold less enclosure (LE) as standard. Not available in 10mA.



56RCD2030GY



56C310RCD30RO and 56MF
(Supplied separately)



56C310RCD30GY

Cat No		56RCD2030	56C310RCD30	56C316RCD30	56C320RCD30
Rated Operational Voltage Ue (~50Hz)	Volts	240	240	240	240
Rated Thermal Current Enclosed	Amps	20	10	16	20
Description		RCD Module only	RCD Protected 10A Socket	RCD Protected CEE17 Socket (Blue)	RCD Protected 20A Socket
RCD MODULE					
Rated Tripping Current		30mA	30mA	30mA	30mA
Rated Tripping Time (approximate)		30mS	30mS	30mS	30mS
SOCKET					
Number of Socket Pins (Including Earth ⊕)			3	3	3
Socket Configuration refer Pg 55			A	W	F
Cable Cross Section	Min	1.0	1.0	1.0	1.0
Solid or Stranded mm ²	Max	10	6	6	10
IP Rating		IP66	IP66	IP66	IP66

Dimensional Drawings

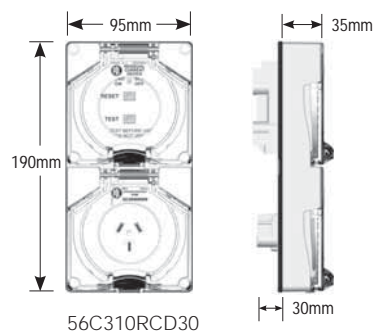

NOTES:

For pin configurations refer to inside back cover – 56 Series™ Product Master – Page 55

RCD Protected Outlets - IP66

Portable Protected Socket Outlets



Two new products for the building and trade industry. Rugged construction using 56 Series™ and Multi 9 technology. Features an easy to carry handle and hanging facility, 2m heavy duty flexible cord set, RCD and overload protection, IP66 rated, and complies with AS/NZS3012 for construction and demolition sites. They are available in chemically resistant orange as standard for the electrical industry.

Cat No	56C310EL2P	56S04ELP15
Rated Operational Voltage Ue (-50Hz) Volts	240	240
Rated Thermal Current Enclosed Amps	10	15
Description	RCD and Overload Protected Socket 10A Plug	RCD Protected 10A Socket 15A Plug
RCD MODULE Rated Tripping Current Rated Tripping Time	30mA 100mS	30mA 100mS
SOCKET Number of Socket Pins (Including Earth Ⓧ)	3	3
Socket Configuration refer Pg 55	A	A
IP Rating	IP66	IP66



56C310EL2PRO

Note: image shows old style 56CV units, these items will change to the New 56 Series from late 2010



Dimensional Drawings

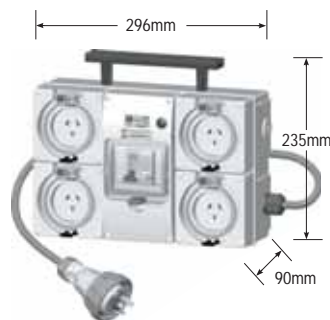

56S04ELP15



Appliance Inlets - IP66

Appliance Inlets - IP66



56 Series™ Appliance Inlets can be used with any appropriately rated cord connector maintaining the IP66 rating. Appliance Inlets are to be mounted vertically into a standard 2 gang or larger enclosure. Note: 56AI310 and 56AI315 fit on a standard 56E1 enclosure.

A captive clear cover is provided for sealing out water and dust to maintain the IP66 rating when not in use. These are available as a spare: Cat 56PC.

Available	Available grey (GY) only, except 56AI310 and 56AI315 available in chemically resistant orange (RO) and white (RW).
Note	Note: All products are sold less enclosure (LE) as standard.



56AI310GY



56AI532GY

Cat No		56AI310	56AI315	56AI320	56AI332	56AI416	56AI420	56AI532
Rated Operational Voltage Ue (~50Hz)	Volts	250	250	250	250	500	500	500
Max. Thermal Current Enclosed	Amps	10	15	20	32	16	20	32
Number of Pins (Including Earth ⊕)		3	3	3	3	4	4	4
Pin Configuration refer Pg 55		A	D	f	g	h	j	k
Terminal Capacity mm ²	Min	1	1	1	2.5	1	1	2.5
	Max	6	6	6	16	6	6	16
IP Rating		IP66 *	IP66**	IP66	IP66	IP66	IP66	IP66

* when used with 56CSC310 only

** when used with 56CSC315 only

Cat No		56AI440	56AI450	56AI516	56AI520	56AI532	56AI540	56AI550
Rated Operational Voltage Ue (~50Hz)	Volts	500	500	500	500	500	500	500
Max. Thermal Current Enclosed	Amps	40	50	16	20	32	40	50
Number of Pins (Including Earth ⊕)		4	4	5	5	5	5	5
Pin Configuration refer Pg 55		l	m	n	o	p	q	r
Terminal Capacity mm ²	Min	2.5	4	1	1	2.5	2.5	4
	Max	16	16	6	6	16	16	16
IP Rating		IP66	IP66	IP66	IP66	IP66	IP66	IP66

Dimensional Drawings

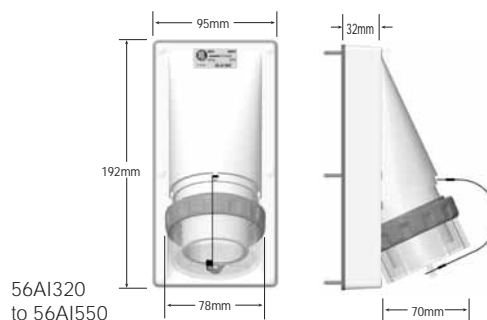
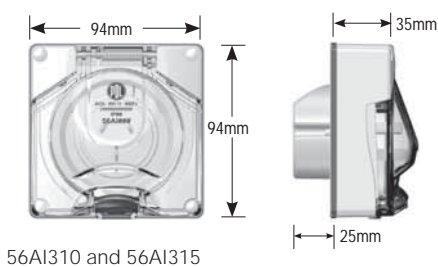

NOTES:

For pin configurations refer to inside back cover – 56 Series™ Product Master – Page 55



Powerful design, trusted brand,

Snap-Shut Bodies

Screw-less assembly using a 'latching' spring

- FAST
- Improved reliability
- Speed & simplicity
- Product strength



Press (clip)
remove (driver)
& twist (body)



Twist & click
locks shut 'Latching'
spring clip

MACTRO™ Technology

A revolutionary cord clamp and cable seal system

- FAST
- Locks shut
- Fewer parts
- Stronger than the existing cord clamp
- Patented – designed in NZ for NZ
- Negates the 'onion ring' approach
- Reliable



Cross-section



Quick Connect Terminals

Positive connection – proven technology



Positive
connection
Existing
& proven
technology –
25 years plus



FAST
Cannot
'rattle – out'
Cannot
over-tighten
termination

Note: Screwed terminal versions available

Ergonomically Superior

New lock-ring, improved plug shape, easier to use

Old

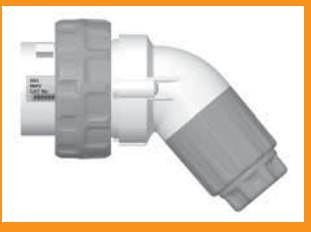

New



Longer lock-ring,
easier access
& operation

Clean lines,
minimising dirt
build-up areas

Better grip
for users



How they work

MACTRO™ Cord Clamp & Seal

OPEN



INSERT 56MACTRO clip & ROTATE to UNLOCK

OR



PRESS (Spring) & REMOVE (Driver)



UNLOCK - lock tab



UNSCREW - cable nut

No need to remove the cable nut! It can stay on as you feed the cable.

CLOSE



SCREW UP - cable nut



LOCK - lock tab

The clamp grips the cable better than any traditional cord clamp, and is locked in place by a locking tab, preventing users from unscrewing.

Quick Connect Terminals



To Terminate:

- 1) Push driver into slot to open terminal
- 2) Insert stripped, untwisted cable into terminal, & release driver from slot. DONE

To Release:

- 1) Push driver into slot to open terminal - pull out cable. DONE

The terminals act on spring tension and clamp the cable in place. They do this in a more consistent and reliable manner than traditional screwed terminals.

Snap-Shut Bodies

OPEN



PRESS clip
REMOVE driver
TWIST body left to open

The 'latching' spring clip stays down once it is pressed, so it is just a simple PRESS & TWIST.

CLOSE



ALIGN arrows
TWIST body right and
CLICK to close
Note: the click may not be audible so give a light twist in either direction to check

Could not be easier!
The spring clip when shut does not exert any stress on the housings, thus resulting in a stronger body and sleeve connection area.

Materials

As with the existing 56 Series™ plugs and connectors the same materials have been maintained within these new products as we know they have a proven performance history.

PLASTICS - industrial grade resins with superior high-impact strength, and UV protection. Fully orange plugs & connectors are available and use a specially formulated chemical resistant material.

METALS - corrosion resistant stainless steel parts using proven grades of materials. High conductivity brass pins on the plugs and sockets.

Performance



Designed and developed in conjunction with practising electrical contractors, as well as dozens of factory visits reviewing usage and user requirements.



Weak areas improved:

- A stronger cord clamp
- A stronger body and sleeve connection
- New connector flap and latch design



Difficult areas improved:

- Easier to unscrew from sockets - a longer lock-ring
- Easier access for maintenance
- Better cable entry set-up (no more onion rings!)
- Less parts
- Easier to grip - promoting proper use



50% Time Reduction* for Installation (approximately).

* Time studies on independent contractors after learning new assembly technique

Testing



Full Standards and Safety Testing Completed. Compliant with AS/NZS3123, AS/NZS3100, AS60529 (IP66), and IEC60309 (QC terminals)



Endurance Testing*:

- QC terminals - withdrawal force approximately 5 times above standards requirements
- Snap-shut bodies - 800+ operations
- MACTRO™ cord clamp and cable seal - operation in extreme heat (+55°C), and in extreme cold (-40°C)



In-house testing* (compared to existing):

- Strength - cord clamp up to 12% stronger
- Strength - snap-shut body clips => 18% stronger
- Chemical resistance - body & sleeve area => withstands where existing fails (cracks)
- Impact test (destructive) => various tests results in equal to or better than the existing



In-field testing:

- Prototypes and production samples have found their way to some of the harshest environments NZ can produce.

*This is only a snap-shot of the full testing programme carried out

Plugs - IP66

250V Plugs



The 56 Series™ Single Phase plugs are available in 10A, 15A, 20A and 32A pin configurations to suit the Australian and New Zealand markets. All eight plugs are IP66 rated when in use with 56 Series™ IP66 sockets, combination switched sockets, and RCDs.

The popular small frame sized plugs were fully redesigned and re-launched in 2003 to meet today's market requirements. They are designed with the food industry in mind, removing significant dirt gathering areas, and with a better lock-ring for easier use.

As well as this they are designed for the installer, incorporating an improved cable entry, a hinged single screw cord clamp, and an improved terminal layout.

Features	<ul style="list-style-type: none"> • Transparent body • IP66 rated • M20 rear thread on small frame size plugs, allowing flexibility in cable connection • All plugs feature the certainty of a cord clamp and convenience of rear cable entry for terminals • MACTRO™ in 16A and 20A round pin - refer pages 28-29
Available	<ul style="list-style-type: none"> • Plugs are available in orange/clear as standard and chemically resistant orange which can be ordered by adding "V" to the catalogue number. e.g. 56PAV320. These plugs are fully orange without clear bodies • All plugs supplied with screw terminals as standard • Quick connect (QC) terminals available in some MACTRO™ plugs as listed. To order specify QC in the catalogue number e.g. 56PA420QC • QC terminal plugs are not available in chemically resistant orange or 6 and 7 pin plugs



56P315



56P416QC



56PA332

Cat No (Straight)		56P310	56P310R	56P315	56P320F	56P320	56P332
Cat No (Angled)						56PA320	56PA332
		MACTRO™					
Rated Operational Voltage Ue (~50Hz)	Volts	250	250	250	250	250	250
Max. Thermal Current Enclosed	Amps	10	10	15	20	20	32
Number of Pins (Including Earth Ⓧ)		3 (Flat)	2 (Flat) & 1 (Round)	3 (Flat)	3 (Flat)	3 (Round)	3 (Round)
Pin Configuration refer Pg 55		A	B	D	E	f	g
Cable Entry Diameter mm	Min Max	7 11	7 11	7 11	7 11	7 16	10 27
Terminal Capacity screw terminal mm²	Min Max	0.75 1.5	0.75 1.5	1.0 1.5	1.0 1.5	1 6	2.5 16
Terminal Capacity quick connect mm²	Min Max					1 4	

Dimensional Drawings

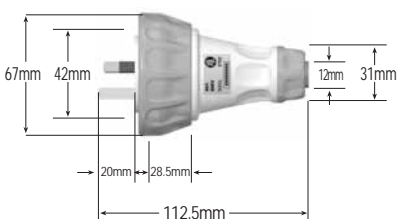

56P310

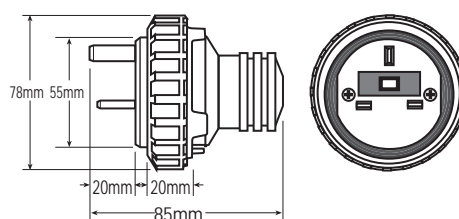

56P313

NOTES:

For pin configurations refer to inside back cover – 56 Series™ Product Master – Page 55

For details on the all new MACTRO™ plugs refer to pages 28 and 29





500V Plugs



These plugs are all rated IP66 when fitted to a 56 Series™ cord connector or Socket Outlet. The body section is transparent for quick and easy inspection of the terminals and cable entry. Plugs are available with 4 to 7 pins, 16A to 50A to cover most applications.

Available

• Refer to page 30 for detail



56PA516QC and 56MACTRO



56PV432

Cat No (Straight)	56P416	56P416K**	56P420	56P432	56P440	56P450	56P516
Cat No (Angled)	56PA416	56PA416K	56PA420	56PA432	56PA440	56PA450	56PA516
	MACTRO™	MACTRO™	MACTRO™				MACTRO™
Rated Operational Voltage Ue (-50Hz)	Volts	500	500	500	500	500	500
Rated Thermal Current Enclosed	Amps	16	16	20	32	40	16
Number of Pins (Including Earth Ⓞ)		4	4	4	4	4	5
Pin Configuration refer Pg 55		h	i	j	k	l	n
Cable Entry Diameter mm	Min Max	7 16	7 16	7 16	10 27	10 27	10 27
Terminal Capacity screw terminal mm ²	Min Max	1 6	1 6	1 6	2.5 16	2.5 16	4 6
Terminal Capacity quick connect mm ²	Min Max	1 4		1 4			1 4

** Special keyway for high cycle applications

Cat No (Straight)	56P520	56P532	56P540	56P550	56P616	56P716	56P720
Cat No (Angled)	56PA520	56PA532	56PA540	56PA550	56PA616	56PA716	56PA720
	MACTRO™				MACTRO™	MACTRO™	MACTRO™
Rated Operational Voltage Ue (-50Hz)	Volts	500	500	500	500	500	500
Rated Thermal Current Enclosed	Amps	20	32	40	50	16	20
Number of Pins (Including Earth Ⓞ)		5	5	5	6	7	7
Pin Configuration refer Pg 55		o	p	q	r	s	u
Cable Entry Diameter	Min Max	7 16	10 27	10 27	10 27	7 16	7 16
Terminal Capacity screw terminal mm ²	Min Max	1 6	2.5 16	2.5 16	4 16	1 6	1 6
Terminal Capacity quick connect mm ²	Min Max	1 4					
Auxiliary Pins C1-C2 Maximum Current					10A	10A	10A



56P420QC

Dimensional Drawings

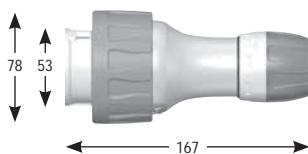

56P320 to 56P720 (16A ~ 20A)

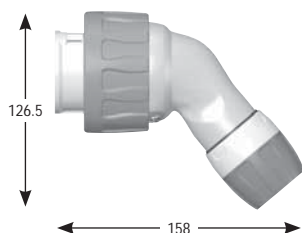

56PA320 to 56PA720 (16A ~ 20A)

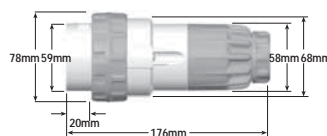

56P432 to 56P550 (32A ~ 50A)

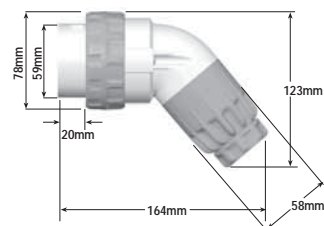

56PA432 to 56PA550 (32A ~ 50A)

Pendant Outlet - IP66

Switched Pendant Outlet



A 56 Series™ Switched Pendant Outlet that combines safety, performance, and functionality. An IP66 rated outlet that provides the ability to disconnect the supply without unplugging and from a prominent location.

Features	<ul style="list-style-type: none"> • A positive activating slide switch • Double pole switching • Built-in hanging facility • New easy-use connector flap • Ample wiring room • Optional neon indication
Available	Available in chemically resistant orange and white only. Specify RO or RW.



56SP0310RO

Cat No		56SP0310	56SP0315
Rated Operational Voltage Ue (~50Hz)	Volts	250	250
Max. Current Enclosed	Amps	10	15
Number of Pins (Including Earth Ⓢ)		3	3
Socket Configuration refer Pg 55		A	D
Switch Description		1 way Double Pole	1 way Double Pole
Cable Entry Diameter	Min Max	7 11	7 11
Terminal Capacity mm ²	Min Max	0.75 2.5	0.75 2.5
IP Rating		IP66	IP66





Cord Connectors - IP66

Cord Connectors



Cord Connectors can be used with any 56 Series™ Plug or Appliance Inlet maintaining the IP66 protection. The body section and flap are both transparent for quick and easy identification of the socket configuration and the cable termination.

Available

Available in orange/clear as standard, and also can be ordered in chemical resistant by adding a "V" to the stock code (i.e. 56CRV310), or RO for the CSCs (i.e. 56CSC310RO). These connectors are fully orange.

Cat No	56CR320				56CR416		56CR420	
	56CSC310	56CR310	56CSC315	56CR315	MACTRO™	56CR332	MACTRO™	MACTRO™
Rated Operational Voltage Ue (-50Hz)	Volts	250	250	250	250	250	500	500
Maximum Current Enclosed	Amps	10	10	15	15	20	32	16
Number of Socket Pins (Including Earth Ⓧ)		3	3	3	3	3	4	4
Socket Configuration refer Pg 55		A	A	D	D	F	G	H
Cable Entry Diameter mm	Min	7	6	7	7	7	10	7
	Max	11	9	11	11	16	27	16
Terminal Capacity mm ²	Min	1	1	1	1	1	2.5	1
	Max	1.5	1.5	1.5	1.5	6	16	6
IP Rating		IP66*	IP66	IP66**	IP66	IP66	IP66	IP66

* when used with 56AI310

** when used with 56AI315

Cat No	56CR516			56CR520		56CR532			56CR540		56CR550	
	56CR432	56CR440	56CR450	MACTRO™	MACTRO™	56CR532	56CR540	56CR550	56CR532	56CR540	56CR550	
Rated Operational Voltage Ue (-50Hz)	Volts	500	500	500	500	500	500	500	500	500	500	
Maximum Current Enclosed	Amps	32	40	50	16	20	32	40	50	32	40	
Number of Socket Pins (Including Earth Ⓧ)		4	4	4	5	5	5	5	5	5	5	
Socket Configuration refer Pg 55		K	L	M	N	O	P	Q	R	P	Q	
Cable Entry Diameter mm	Min	10	10	10	7	7	10	10	10	10	10	
	Max	27	27	27	16	16	27	27	27	27	27	
Terminal Capacity mm ²	Min	2.5	2.5	4	1	1	2.5	2.5	4	2.5	2.5	
	Max	16	16	16	6	6	16	16	16	16	16	
IP Rating		IP66	IP66	IP66	IP66	IP66	IP66	IP66	IP66	IP66	IP66	



56CSC310



56CR420



56CR432

NOTES:

For details on the all new MACTRO™ connectors refer to pages 28 and 29



Dimensional Drawings

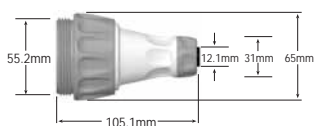

56CSC310 to 56CSC315

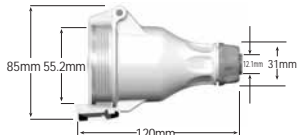

56CR310 to 56CR315

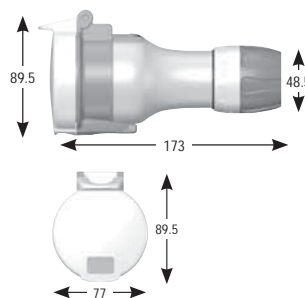

56CR 16A to 20A

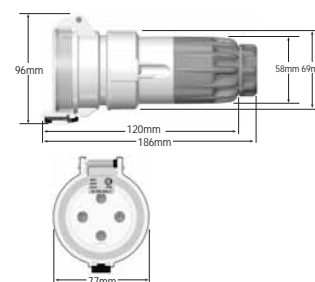

56CR 32A to 50A

DIN Mounting MCB/RCD Covers - IP66

DIN Rail Mounting Covers for MCBs, RCDs or any full DIN mounting accessory.

56CB4



Two gang cover that fits up to 4 poles (72mm) in width. Provided with 1x18mm DIN opening and 6x9mm breakouts. Supplied with full DIN rail and mounting bracket for fitting to a standard 56E2 or larger enclosure. DIN rail and brackets (2) kit is available as a spare. To order, specify: 1CB100.

Features	<ul style="list-style-type: none"> • IP66 rated • Clear pad lockable flap cover • Dual 415V/240V neon
Available	Grey, orange, white.
Note	Supplied less enclosure (LE) as standard.



56CB4GY with Multi 9 23358 RCCB

Cat No	56CB4	
Number of Poles		4
Module Width	mm	72 (4x18)
Neon Voltage (~50Hz)	Volts	415V/240V
DIN Rail Mounting Height	Min Max	48mm 62mm
IP Rating		IP66

56CB13



Thirteen way fully equipped distribution board. Complete with DIN rail, 1 x Earth and 2 x Neutral bars as standard, all fitted with links (where applicable) to a base enclosure the same size as a 56E6.

Features	<ul style="list-style-type: none"> • IP66 rated • Clear pad lockable flap cover • Complies with AS/NZS3439.3 • Supplied with accessory pack
Available	Grey only. Orange and white on request



56CB13

Cat No	56CB13	
Number of Poles		13
Module Width	mm	234 (13x18)
Rated Operational Voltage (~50Hz)	Volts	415V a.c.
Rated Current of Board		100A with suitable rated cable (25mm)
Rated Insulation Voltage		1000V a.c.
Short Circuit Withstand Strength		10kA
Dimensions (with enclosure)		295Wx123Dx198H
Cable Entries		6x25mm, 2x32mm
IP Rating		IP66

Dimensional Drawings

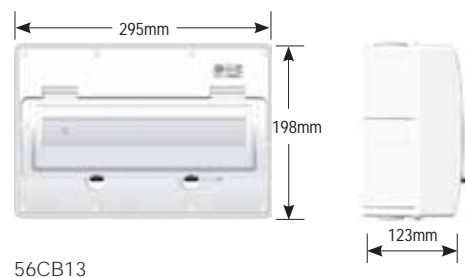
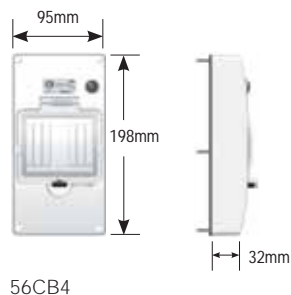



Pendant Outlet Kits Module Mounting Lids

Pendant Outlet Kits



Suspension hooks that can be fitted to 56 Series™ Connectors, enabling a chain or cord to be attached for ceiling mounting.

Cat No	56POK	56POK1	56SHM
	Suits small 10A to 20A Connectors	Suits large 32A to 50A Connectors	Suits medium 16A to 20A MACTRO™



Ø 22 mm Diameter



Lids for mounting either one or two 22mm diameter control modules. Lids can be supplied in grey, orange, white or clear for matching to any control accessories. Ideally suited for the Telemecanique Harmony range of pushbuttons.

Cat No	56L1/22/1	56L1/22/2
Mounting Hole Size	Ø 22.5mm with 3.5mm Keyway	
Mounting Holes	1	2
Mounting Centres		40mm
Colours Available	Grey, Orange, White or Clear	

600 Series IP66 Covers



Covers to suit any 500 or 600 Series module providing IP66 protection. Ideally suited for 500 and 600 Series switches, push buttons, dimmers and neon indicators.

Cat No	56M0500/1	56M0500/2
Mounting Hole Size	For 500 and 600 Series Module Only	
Mounting Holes	1	2
Mounting Centres		30mm



56M0500/1 with 648TM

Dimensional Drawings

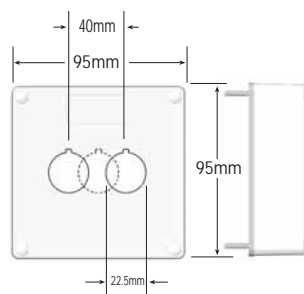

56L1/22/1 56L1/22/2

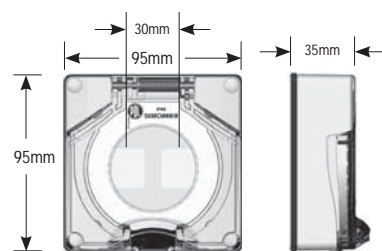

56M0500/1 56M0500/2

Enclosures

Enclosures



56 Series™ enclosures are in three types: shallow, in single and 2 gang sizes, suitable for mounting blank lids, single phase switches, single phase sockets and sunset switches; standard 63mm deep enclosures, which range in size from single gang to 16 gang; and an extra deep 100mm in 2 gang size for mounting large amperage products. They are moulded in impact resistant PVC.

All multigang enclosures are supplied complete with a selection of bridges to provide a sealing base between individual modules and dividers for separating incompatible circuits. Enclosures are supplied with a range of conduit entries according to the chart.

Cat No	56E1S	56E1	56E1/25/25	56E2S	56E2	56E2	56E2/25/25	56E2/40
	Food Industry							
Module Size	1 Shallow	1	1	2 Shallow	2	2	2	2
Module Configuration	1x1	1x1	1x1	2x1	2x1	2x1	2x1	2x1
Dimensions	Length	102	102	102	198	198	198	198
	Width	102	102	102	102	102	102	102
	Depth	38	63	63	38	63	63	63
Conduit Entries Metric mm*	25	2	1	2	2	1	2	2
	32	---	1	1	---	1	---	1
	40	---	---	---	---	---	---	2
Conduit Reducers Supplied	25/20	1	1	2	1	1	2	2
	32/25	-	1	-	-	1	-	1
Rear Entry Cut-Outs	1x25-20	1x32-25	1x32-25	2x25-20	1x32 1x25	1x32 1x25	1x25-20 1x32-25	1x25-20 1x32-25

* Special enclosure threaded entries are available on request. Specify grey (GY), orange (RO), or white (RW).



56E1/25/25RW



56E8GY including dividers

Dimensional Drawings

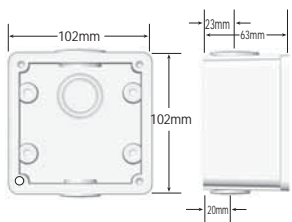

56E1

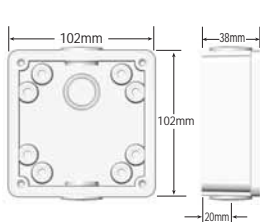

56E1S

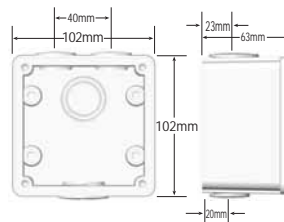

56E1/25/25

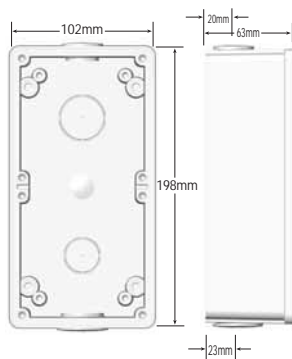

56E2

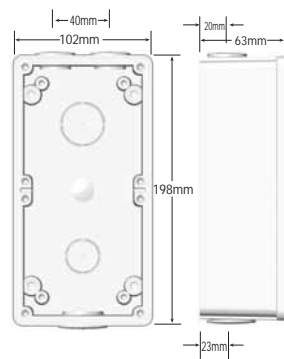

56E2/25/25

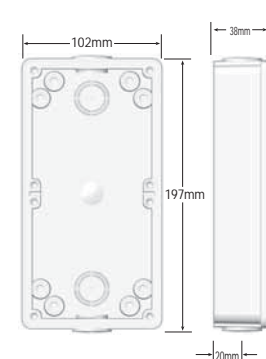

56E2S



56E2V



Enclosures

Cat No	56E2V NEW	56E3	56E4VH	56E4	56E6	56E8	56E9	56ED2/40	56E16	
Module Size	2	3	4	4	6	8	9	2 Extra Deep	16	
Module Configuration	2x1	3x1	4x1	2x2	3x2	4x2	3x3	2x1	4x4	
Dimensions	Length	170	296	396	198	296	396	296	198	396
	Width	104	102	102	198	198	198	296	101	396
	Depth	110	63	63	63	63	63	63	100	63
Conduit Entries Metric mm*	25	---	1	1	2	2	2	3	---	---
	32	1	1	1	4	2	2	3	---	4
	40	---	---	---	---	---	---	---	2	4
Conduit Reducers Supplied	25/20	---	1	---	1	---	1	---	---	4
	32/25	1	1	---	1	1	1	---	---	4
Rear Entry Cut-Outs	1x32-25	3x32-25	2x25	2x32-25	2x25	4x25	4x25	1x25	8x25	
		1x32	1x32	2x32	2x32	2x32	3x32	1x32	4x32	
		1x40	1x40	2x40	2x40	2x40	2x40		4x40	

* Special enclosure threaded entries are available on request.

Dimensional Drawings

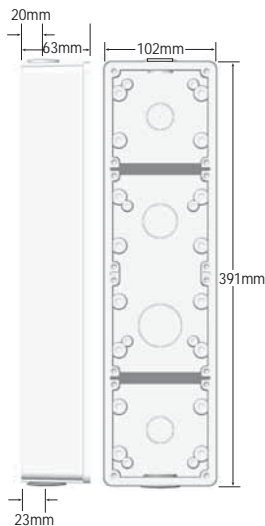

56E4VH

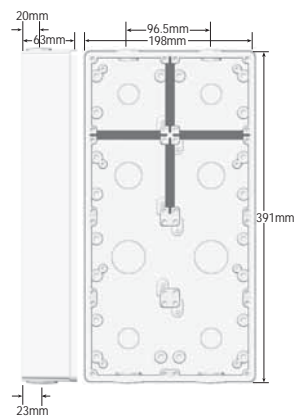

56E8

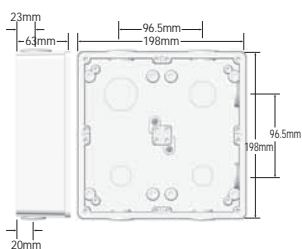

56E4

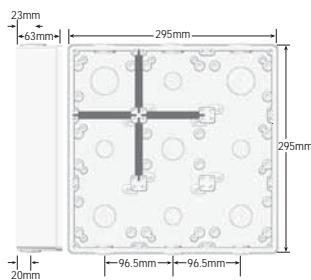

56E9

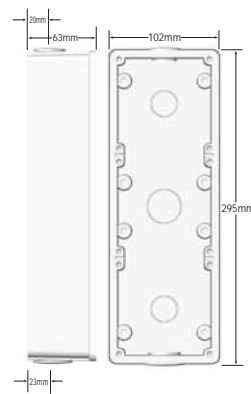

56E3

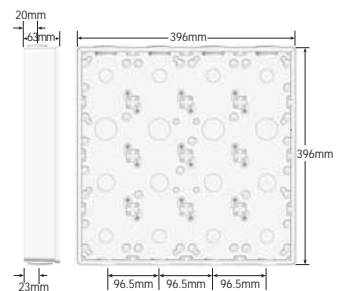

56E16

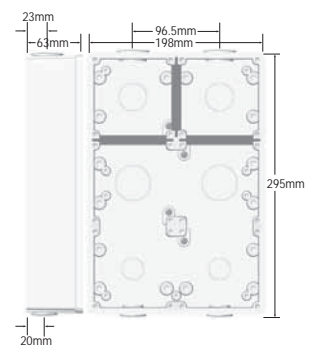

56E6

Lids

Lids



56 Series™ Lids are available in 1 gang to 6 gang module sizes in both grey and clear, impact resistant polycarbonate or chemically resistant orange and white. Lids can be used in conjunction with enclosures or other product in the series to produce a wide range of power distribution centres or utility boxes.

Available	Available in high impact grey and clear, or chemically resistant orange and white. Except 56XDL1 is only available in grey and clear. Specify GY, CL, RO or RW, i.e. 56L1GY.
Note	All products come supplied less enclosure. Options are available fitted with enclosure: 56 Series™ utility boxes in grey and clear, shallow and standard, with some fitted with gear trays. Refer to the latest Schneider Electric pocket book for details.



56L2RO fitted to 56E2RO

Cat No	56L1	56L2	56L3	56L4	56XDL1	56DL2	56DL4	56DL6
Module Size	1	2	3	4	1	2	4	6
Module Configuration	1x1	2x1	3x1	2x2	1x1	2x1	2x2	3x2
Dimensions	Length	95	191	289	95	191	191	289
	Width	95	95	95	191	95	191	191
	Depth	28	28	30	28	100	63	63

Dimensional Drawings

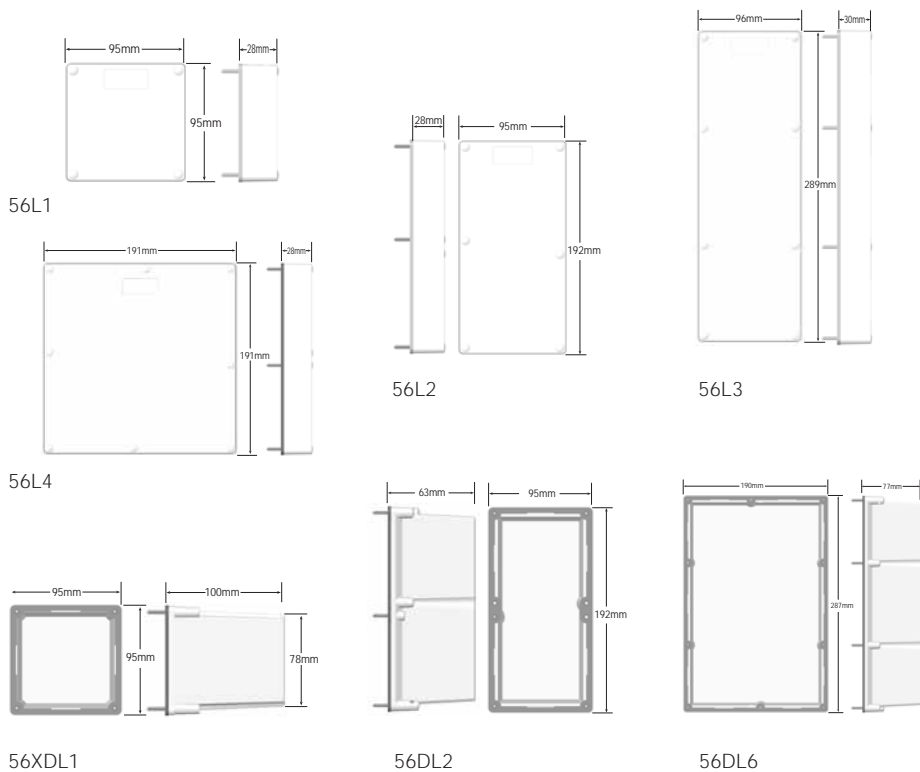

56DL4CL fitted to 56E4GY





Pendant Enclosures Flush Surrounds

Pendant Enclosures



The Pendant Enclosure allows you to mount two 56 Series™ single gang products in a fully enclosed, portable unit so you can hang up your power supply.

A divider separates the two mounted products and produces a seal to ensure the IP66 rating.

In the interests of user convenience, the enclosure features finger recesses for holding while unplugging the plug from the socket.

They have a strong, large loop for attaching a chain, as well as angled cable entry for ease of wiring.

Available Available in high-impact grey and chemically resistant orange and white.



56PE2/32

Cat No	56PE2/25	56PE2/32
Conduit Entries	1x25mm	1x32mm
Conduit Reducers Supplied	1x25/20mm	-
Module Size	1x2	1x2

Flush Surrounds



Supplied with metal wall mounting plate and foam sealing gasket. Ideal for flush mounting of 1 to 4 gang accessories maintaining the IP66 protection. Moulded in impact resistant UV stabilised PVC.

Available Available in grey (GY), orange (RO), and white (RW).

Cat No	56FA1	56FA2	56FA3	56FA4
Module Size	1	2	3	4
Module Configuration	1x1	2x1	3x1	2x2
Dimensions	Length 157 Width 157	254 157	350 157	254 254

56FA Series Mounting Details

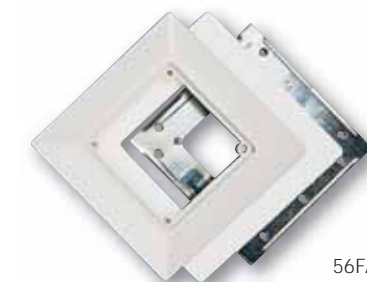
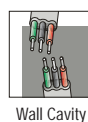
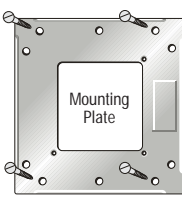
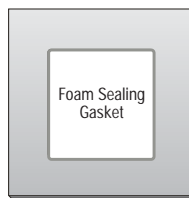

56FA1GY



56FA2GY

Dimensional Drawings

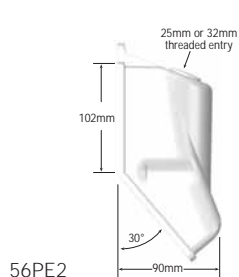

56PE2

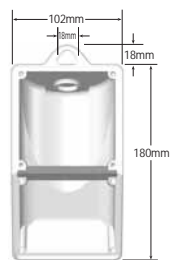

56FA1

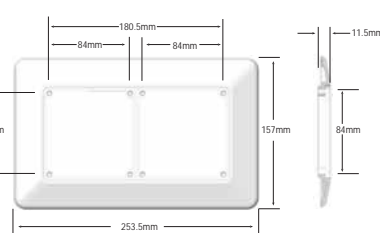
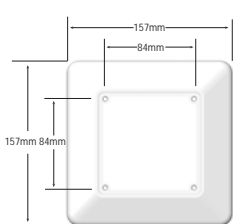

56FA2

Accessories

Plugs and Connectors



The 56 Series™ has a comprehensive range of plug bodies and plug sleeve kits. These allow for the replacement of damaged plug bodies or sleeves through extensive use or misuse.

They are available in all plug sizes from 16A up and in both standard impact resistant polycarbonate or chemical resistant orange.

Plug bodies also fit 56 Series™ cord connectors.



Plug Sleeve



Plug Body

Plug Bodies

Cat No	Description
56P16/20A	16/20A Straight
56PA16/20A	16/20A Angled
56P32/35A	32/35A Straight
56PA32/35A	32/35A Angled
56P40/50A	40/50A Straight
56PA40/50A	40/50A Angled

Plug Sleeve Kits

Cat No	Description
56P16	16A
56P20/250	20A 3 pin
56P32/250	32A 3 pin
56P20/500	20A 4+ pin
56P32/500	32A 4+ pin
56P40	40A
56P50	50A

MACTRO™



M25 threaded adaptor suiting 16A and 20A MACTRO™ plugs and connectors. Unlock tool for MACTRO™ cable entry glands.

Cat No	Description
56AM25	Conduit Nut Adaptor M25
56MACTRO	Cable Gland Unlock Tool



56AM25



56MACTRO front



56MACTRO rear

Mounting Feet



Mounting for 56 Series™ enclosures enabling the boxes to be recessed out from the wall or mounting area. An advantage for high quality hygiene areas.

Cat No	56MF
Material	316 Stainless Steel
Stand off height	9.0mm
Mounting Centres	82mm
Package Contents	
Mounting Feet	2
Mounting Screws	4



Mounting Feet

Socket Covers



Covers cater for all 56 Series™ standard socket products to allow safe replacement of damaged covers.

Cat No	56SOCOVER
Description	Socket Cover General



56SOCOVER

Gaskets

NEW



Replacement gaskets for worn or damaged units, as well as gaskets for improved protection in high pressure wash down situations.

Cat No	Description
56G1	Single Module Gasket
56G2	Double Module Gasket
56HPG1	High Pressure – 1 Gang
56HPG2/1	High Pressure – 2 Gang, 1 Piece
56HPG2/2	High Pressure – 2 Gang, 2 Piece

Enclosures



Replacement parts to suit 56 Series™ enclosures.

Cat No	Description
56BRIDGE	Enclosure Bridge
56DIVIDER	Enclosure Divider
3S130	Enclosure Mounting Pillar



56HPG1



56HPG2/1



56HPG2/2



56 Series™ D.O.L Motor Starters - IP66

The Watertight Motor Starter Solution with features designed to outperform all others...

- ➔ • 56 Series™ Compatible • IP66 Protection • NZ Made for NZ Conditions • Combination Isolating Switch/D.O.L Motor Starter

Description	
1	Pre-wired
2	Unique cover mounted contactor and overload (allows for first fitting of enclosure and conduit if required)
3	Both 230V and 400V versions available
4	AC23 11kW motor rated switch
5	Maximum contactor rating 5.5kW (7.5hp)
6	1x25mm conduit entry
7	2x20mm conduit entries
8	Finger proofing on all terminals
9	Shrouded push buttons
10	Available with or without enclosure
11	High impact resistant UV stabilised polycarbonate cover
12	Raised stop button
13	Enclosure manufactured from UV stabilised rigid PVC
14	Easy adjustment of overload setting, no tools required
15	Terminal screws combination slot-pozi head

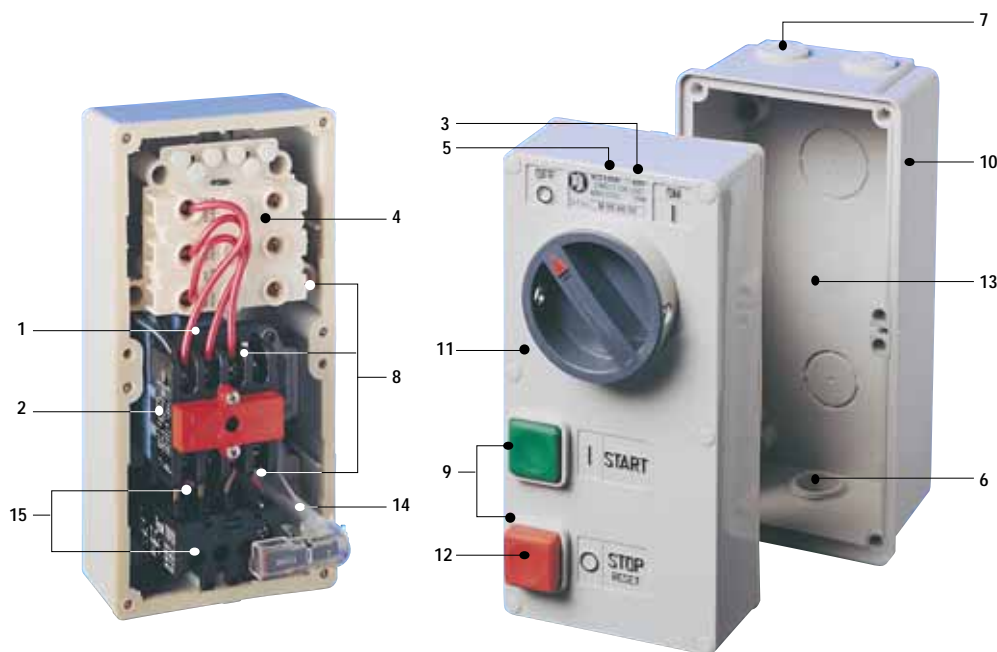

For tough motor control situations!

- ➔ A range of rugged, dependable D.O.L. Motor Starters, for single phase motors up to 2.2kW (3.0hp) and three phase motors up to 5.5.kW (7.5hp). For maximum versatility and flexibility there are four versions in each of the single and three phase options:

1	START/STOP RESET
2	STOP/RESET only
3	START/STOP RESET with isolating switch
4	STOP/RESET with isolating switch





Connection Diagrams

Starter and Overload



Typical connection diagrams for motor starter options, full instructions and connection diagrams are supplied with products.

Technical Information

GENERAL

Direct on Line Motor Starter			
Maximum Rated Output	AC3 5.5kW AC3 2.2kW	400V – Three Phase 230V – Single Phase	
Maximum Thermal Current Enclosed	16A		
IP66 Dust and Watertight	AS 1939:1990 BS 5490:1985 IEC 529 :1989		
Finger proof terminals on contactor, overload and isolating switch to IP20			

CONTACTOR

Type	S12 10 Electromagnetic Contactor 3 pole + N/O Auxiliary		
Frequency	50Hz AC		
Utilisation Category	AC3 7.5kW AC3 2.2kW	400V – Three Phase 230V – Single Phase	
Rated Insulation Voltage Ui	690V-		
Rated Thermal Current Enclosed	16A		
Coil Characteristics	Pull in 0.85 - 1.1 Uc (Control Circuit Voltage) Drop Out 0.4 - 0.6 Uc		
Terminal Capacities	Stranded 0.5 - 2.5mm ² Solid 0.75 - 4mm ²		

ENCLOSURE

Rigid PVC – UV stabilised, impact resistant.
Screwed Conduit Entries Back Entry Cut-Outs
1 x Ø 25mm 1 x Ø 32mm
2 x Ø 20mm 1 x Ø 25mm

MOTOR RATED ISOLATING SWITCH

Used with 56MS230SW, 56MS400SW, 56MS230SWR, 56MS400SWR 3 pole isolating. Motor rated to			
AC23	11kW	415V	BS5419
M110	20A	500V	AS3133

START PUSH BUTTON SWITCH

Rated Insulation Voltage Ui	500V AC		
Rated Thermal Current	16A		
Utilisation Category	AC11 4A AC11 2A	250V 415V	

TERMINAL CAPACITIES

Main	Stranded 0.5 - 2.5mm ² Solid 0.5 - 4mm ²
Auxiliary	Stranded 0.5 - 2.5mm ² Solid 0.5 - 2.5mm ²

OVERLOAD

Full Load Current Rating	0.40 - 16 Amps in 10 size ranges
Rated Insulation Voltage	Ui: 660V AC
Single Phase Protected Temperature Compensated	From 0 - 35°C
Manual or Auto Reset	
Manual Test Incorporated	
Alarm Control	N/O

AUXILIARY CONTACTS

Rated Insulating Voltage	500V AC
Rated Operational Current Ie	AC11 2A 500V

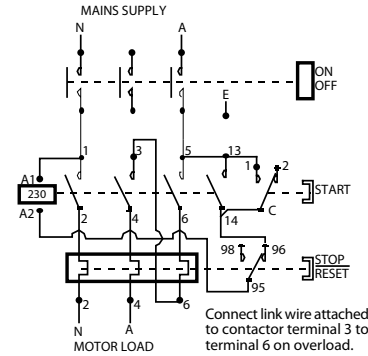

Single Phase & Neutral Supply – 56MS230SW

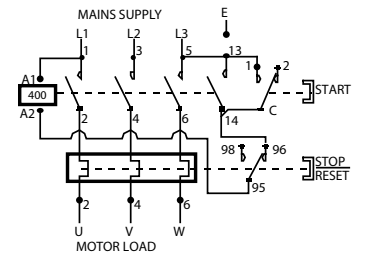

3 Phase 3 Wire Supply – 56MS400

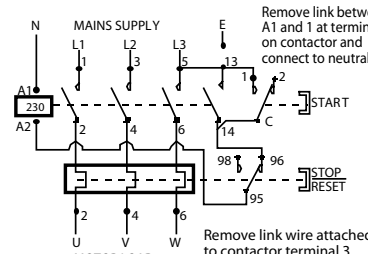

3 Phase 4 Wire Supply – 56MS230

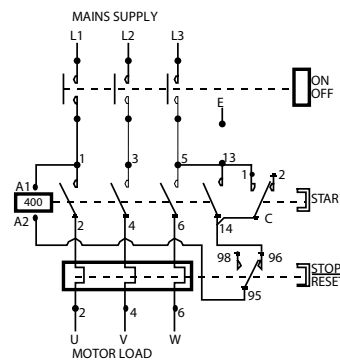

3 Phase 3 Wire Supply – 56MS400SW

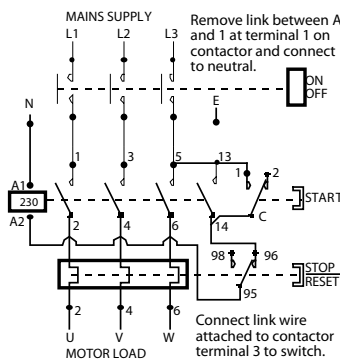

3 Phase 4 Wire Supply – 56MS230SW

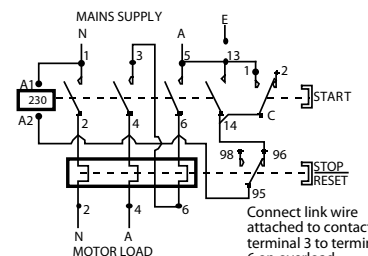

Single Phase & Neutral Supply – 56MS230

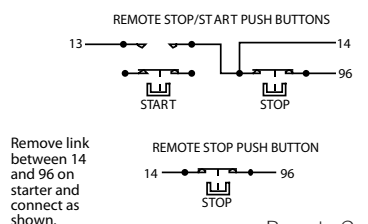

Remote Controls

Overload Selection

Replacement Coils

Cat No	Description
56MSC230	230V~50Hz Coil
56MSC400	400V~50Hz Coil
56MSC24	24V~50Hz Coil

Overloads

Cat No	Description	Cat No	Description
56T9062	0.4-0.62A	56T942	2.7-4.2A
56T9092	0.6-0.92A	56T962	4.0-6.2A
56T913	0.85-1.3A	56T992	6.0-9.2A
56T919	1.2-1.9A	56T9120	8.0-12.0A
56T928	1.8-2.8A	56T9160	11.0-16.0A

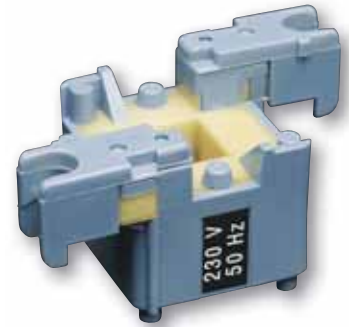

Direct on Line Starter, Full Load Current

MOTOR RATING		THREE PHASE 400V		SINGLE PHASE 230V	
kW	HP	Adjustment Range (A)	Recommended Overload	Adjustment Range (A)	Recommended Overload
0.18	0.25	0.6-0.92	56T9092	1.8-2.8	56T928
0.25	0.33	0.6-0.92	56T9092	2.7-4.2	56T942
0.37	0.50	0.85-1.3	56T913	4-6.2	56T962
0.55	0.75	1.2-1.9	56T919	4-6.2	56T962
0.75	1.0	1.8-2.8	56T928	6-9.2	56T992
1.1	1.5	2.7-4.2	56T942	8-12	56T9120
1.5	2.0	2.7-4.2	56T942	11-16	56T9160
2.2	3.0	4-6.2	56T962		
3.0	4.0	6-9.2	56T992		
4.0	5.5	6-9.2	56T992		
5.5	7.5	8-12	56T9120		



NOTE: "Full Load Currents" given in this table are intended as a guide only. For exact full load current, consult the motor manufacturer's specifications or the motor nameplate.

Thermal Overload Characteristics

Average values at 20°C ambient temperature, tripping three phase from cold condition

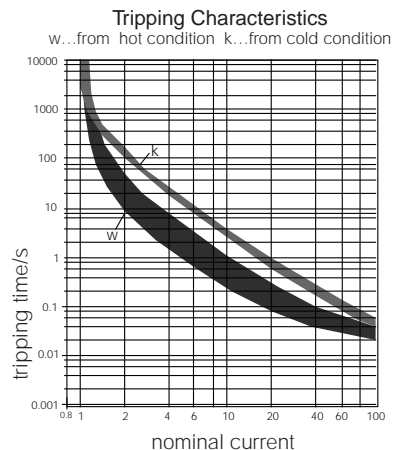

Short Circuit Capability

Setting Range (A)	Max. Fuse Ratings (A)			
	quick(+)		slow(+)	
	a	c	a	c
0.40 – 0.62	35	4	25	4
0.60 – 0.92	35	6	25	4
0.85 – 1.3	35	6	25	4
1.2 – 1.9	35	10	25	6
1.8 – 2.8	35	16	25	10
2.7 – 4.2	35	25	25	20
4 – 6.2	—	35	25	20
6 – 9.2	—	35	—	25
8 – 12	—	35	—	25
11 – 16	—	35	—	25

According to IEC 292-1A coordination types "a" and "c".



International Standards and Approvals

Technical Information

DIRECT ON LINE MOTORSTARTER

International Protection IP66 to AS 1939:1990 and BS 5490:1977.
 AS 1202 Pt 1:1981 AC Motorstarters
 Direct on Line
 BS 4941 Pt 1:1979 Direct on Line AC
 Starters IEC 947, switch operation and cover marking
 Patented Stop/Reset Mechanism
 The switched versions (56MS400SW and 56MS230SW)
 comply with New Zealand Electrical Wiring Regulation 108.
 Manufactured to ISO 9001

CONTACTOR

IEC 947
 EN 60947
 VDE 0660
 Manufactured to ISO 9001

OVERLOAD

IEC 292
 VDE 0660
 BS 587 and BS 5424
 Manufactured to ISO 9001

Definition of Utilisation Categories

Technical Information

AC23A

Switching of motor loads or other highly inductive loads.
 Occasional:
 Making 10 times I_e
 (Rated operational current)
 Breaking 8 times I_e

AC3

Starting of squirrel cage motors, and switching off motors during running.
 Occasional:
 Making 10 times I_e
 Breaking 10 times I_e

AC11

Feed control of magnetic drives, contactors, valves and electromagnets.
 Occasional:
 Making 11 times I_e
 Breaking 11 times I_e



Technical Section

Chemical Resistance

Chemical Compatibility	56 Series Grey	56 Series Orange & White	56 Series Enclosures
Acids			
Hydrochloric Acid (10%)	A	A	A
Sulphuric Acid (10%)	A	A	A
Acetic Acid (10%)	A	A	A
Nitric Acid (10%)	B	A	A
Bases			
Potassium Hydroxide	C	A	A
Sodium Hydroxide	D	B	A
Ammonium Hydroxide	D	B	B
Organic Solvents			
Ethyl Alcohol	A	A	A
Methyl Alcohol (Methanol)	B	A	A
Isopropyl Alcohol	A	A	A
Acetone	D	B	D
Methylethylketone	D	D	D
Ethyl Acetate	D	A	N/T
Ethylene Glycol	B	A	N/T
Methyl Benzene	D	B	D
Xylene	D	C	D
Automotive Related Environments			
Motor Oil	C	A	N/T
Transmission Fluid	D	B	N/T
Power Steering Fluid	D	B	N/T
Brake Fluid	D	C	N/T
Unleaded Petrol	D	B	A
Diesel Fuel	A	A	A

Chemical Compatibility	56 Series Grey	56 Series Orange & White	PDL Enclosures
Salts			
Zinc Chloride (10%)	B	A	B
Calcium Chloride (10%)	B	A	B
Sodium Chloride (5%)	B	A	B
Oxidising Agents			
Sodium Hypochlorite (5%)	A	A	A
Hydrogen Peroxide (30%)	A	A	A
Others			
Mild Detergent	B	A	A
Hot Water @ 60 degrees	A	A	B
Mechanical and Thermal Properties			
Outdoor Use – Mechanical Properties	A	A	
Outdoor Use – Colour Properties	B	B	
Indoor Use	A	A	A
Lightweight	A	A	A
High Rigidity	B	B	
Impact Resistance	A	B	C
UV Deterioration	A	B	A

This table is a guide only. Performance of product in a particular environment will be affected by a wide variety of factors, of which chemical compatibility is only one. End users should test for their particular environment.

RATINGS

- A – Excellent Compatible, no problems expected from the use of the chemical with this part.
- B – Good Acceptable, minimal loss of chemical properties after prolonged exposure.
- C – Fair Marginally compatible, extended use of the chemical may cause deterioration and cracking of the part.
- D – Poor Incompatible. Do not recommend the use of the chemical with this part.
- N/T Not Tested

Rating Conversion

1 PHASE		
kW	hp	240V A
0.37	0.5	3.6
0.55	0.75	4.8
0.75	1	6.1
1.1	1.5	8.8
1.5	2	11.7
1.8	2.5	14.4
2.2	3	17.1
3	4	22.2
4	5	27.1
4.4	6	31.8
5.2	7	36.5
5.5	7.5	38.7
6	8	40.8
7	9	45.4
7.5	10	50

3 PHASE			
kW	hp	415V A	500V A
0.37	0.5	-	1
0.55	0.75	-	1.21
0.75	1	1.8	1.5
1.1	1.5	2.6	2.2
1.5	2	3.5	2.9
2.2	3	5	3.8
3	4	6.5	5
3.7	5	7.5	5.9
4	5.5	8.4	6.5
5.5	7.5	11	9
7.5	10	15	12
9	12	17	13.9
10	13.5	-	15
11	15	21	18.4
15	20	28	23
18.5	25	35	28.5
22	30	40	33
25	35	47	39.4
30	40	55	45
33	45	60	50

These values are given as a guide only. They may vary depending on the type of motor and the manufacturer.



Switch Rating Information

Glossary

IEC60947-3 Low Voltage Switchgear and controlgear – Switches, disconnectors, switch disconnectors and fuse-combination units. Several ratings are referred to in detail. Note that ratings in the format AC21A can be interpreted as follows:

- **AC** refers to AC supply. Alternative is DC.
- **21** refers to the utilisation of the rating. Alternatives include 15, 23, 3 and detail on each can be found below.
- **A** refers to "frequent operation". No number is specified for frequent operation, although the test programme tests at 30 second intervals. **B** is the alternative, covering infrequent operation, maybe one switching per day or month.

AS/NZS3133 Approval and test specification – Air break switches. Three different ratings are referred to in detail:

- Resistive rating
- M Motor rating
- X Inductive or fluorescent rating

IEC60947-3 International Device Classifications



= Disconnector (Isolating only)

An isolation device, under AS/NZS 3000:2000, section 2.8.3.2 must:

- Be capable of withstanding an impulse voltage likely to occur at the point of installation, or shall have an appropriate contact gap.
- Not be able to falsely indicate that the contacts are open.



= Switch Disconnector
(Or Switch Isolator-Making,
Breaking and Isolating)

IEC60947-3 AC21A Switching of resistive loads including a moderate overload

Pure resistive loads include heating elements. Very few loads, if any, are 100% resistive and this test includes a moderate inductive component in recognition of this.

IEC60947-3 AC23A Switching of motor or other highly inductive loads

As above, this rating covers AC supply and frequent operation. AC23A is the best utilisation category for switching of the most common types of motors. Most other highly inductive loads typically involve motors of some type. Examples are heat pumps, compressors and air conditioners.

The AC23A rating of a 56SW350GY switch is 35 Amps (18.5 kW). This switch can be matched to a motor that has a full load current of up to 35 Amps.

Generally, these switches are used in conjunction with other motor control equipment such as motorstarters or soft starters and only have to operate during a fault or period of isolation.

IMPORTANT

The above information is an opinion only. All installers and equipment users should satisfy themselves as to the suitability of equipment for each particular application. No liability will be accepted for reliance on this information.

Switch Rating Information

IEC60947-3 AC3 Switching of squirrel-cage motors

AC3 has no A or B classification for frequency of operation and all ratings are for frequent operation. AC3 provides ratings directly applicable to the direct starting and switching off of motors during operation and as such is one of the harshest switch ratings available for motors.

The AC3 rating of an 56SW350GY switch is 28 Amps (15kW). This switch can be used to start or stop a motor that has a full load current of up to 28 Amps.

AC3 is the rating best suited for control equipment being turned on or off directly under load. Examples include conveyors, lathes and process equipment. With a frequent operation classification, these switches may be operated many times per hour.

IEC60947-3 AC4 Switching of squirrel-cage motors, starting, plugging and inching

Like AC3, AC4 has no A or B classification for frequency of operation and all ratings are for frequent operation.

AC4 provides ratings in addition to AC3 relating to motors which are rapidly reversed while running (plugging), or operated repeatedly to obtain small movements of a mechanism (inching) and as such is one of the harshest switch ratings available for motors.

The AC4 rating is applied only to the K and N control switches. The 56SW320CO has an AC4 rating of 1.5kW. This switch can be used to make or break a load of 1.5kW.

IEC60947-3 AC15 Control of electromagnetic loads

This rating covers the switch control of electromagnetic loads, including control devices such as relays, contactors, and valves.

IEC60947-3 DC21A Switching of DC resistive loads

As for AC21A except covers DC applications.

IEC60947-3 DC22A Switching of DC mixd resistive and inductive loads

As for DC21A except covers mixed resistive and inductive loads. For example shunt motors.

IEC60947-3 Rated short time withstand current (I_{cs}/kA)

This is the recommended maximum current the switch can withstand under fault conditions without failing or showing signs of damage and is the switch equivalent of a 4.5kA or 6kA rating assigned to an MCB. Values are expressed as kA.

A 56SW350GY switch has a 1.5kA rating so it can carry a 1500 Amp load for 1 second without damage.

IEC60947-3 requires performance of at least 12x rated current for 1 second. 56 Series™ switches offer performance levels much higher than this.

IMPORTANT

The above information is an opinion only. All installers and equipment users should satisfy themselves as to the suitability of equipment for each particular application. No liability will be accepted for reliance on this information.



IEC60947-3 Rated short circuit making capacity (Icm/kAp)

This rating provides performance information relating to the presence of a short circuit condition when the switch is switched ON. Values are given as kAp and indicate that current load can be carried until circuit protection devices activate.

A 56SW350GY switch has a 2.1kAp rating so it can switch ON a 2100 Amp prospective short circuit and carry it for as long as the principal protection devices (MCB or Fuses) take to operate.

A "rated short circuit breaking capacity" relates to the opposite – switching OFF in the presence of a short circuit condition. This rating is not typically published as circuit protection devices are designed to act before a manual switch operation can be undertaken.

Uninterrupted duty

A duty without any off load period in which the main contacts of equipment remain closed, whilst carrying a steady current without interruption for periods of more than eight hours (weeks, months or even years).

AS/NZS3133 Resistive rating

This rating is typically the one quoted most widely for a particular switch. The rating relates to resistive loads with a moderate inductive element.

A 56SW350GY switch has a 50 Amp resistive rating so it can switch ON and OFF a resistive load of 50 Amps.

AS/NZS3133 M Motor rating

M rating indicates the switch is suitable for control of motors with a nominated locked rotor current of XX Amps – MXX.

A 56SW350GY switch has an M200 rating so it can switch ON or OFF under locked conditions a motor with a 200 Amp locked rotor current. The locked rotor current is generally eight to ten times the full load current and simulates current draw when a motor is stalled.

IMPORTANT

The above information is an opinion only. All installers and equipment users should satisfy themselves as to the suitability of equipment for each particular application. No liability will be accepted for reliance on this information.

IP Ratings

1st Figure

Protection against solid objects.

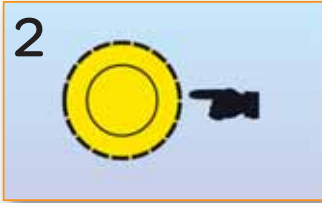

Protected against solid bodies larger than 12mm (e.g. finger of the hand).

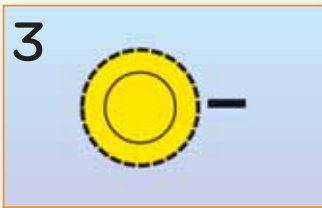

Protected against solid bodies larger than 2.5mm (e.g. tools, wire).

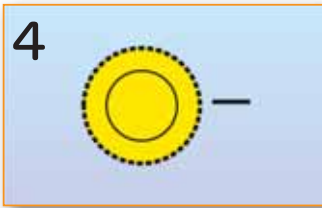

Protected against solid bodies larger than 1mm (fine tools and small wires).



Protected against dust (no harmful deposits).

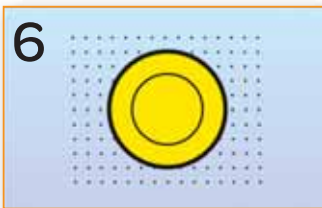

Completely protected against dust.

2nd Figure

Protection against harmful ingress of water.

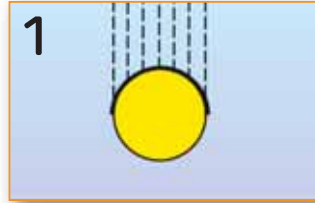

Protected against vertically falling drops of water.

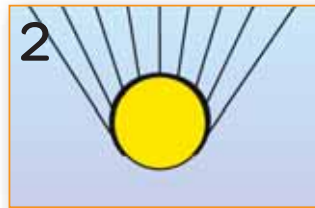

Protected against drops of water falling at up to 15° from the vertical.

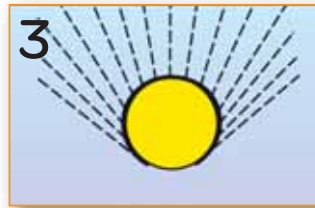

Protected against spraying water at up to 60° from the vertical.

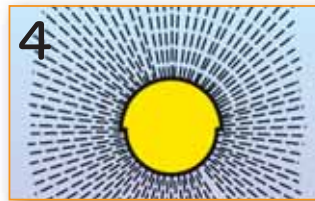

Protected against splashing water from all directions.

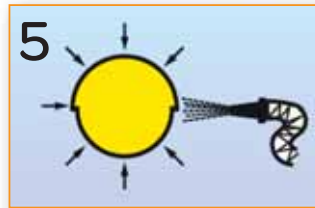

Protected against jets of water from all directions.

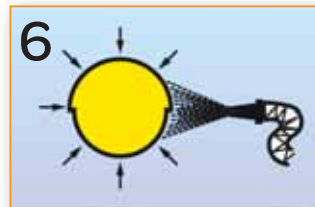

Protected against jets of water of similar force to heavy seas.

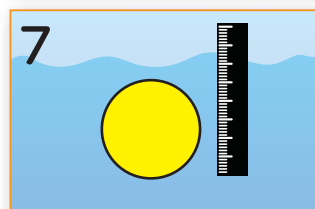

Immersion between 15cm and 1m depth

Tattoo Me



Now the message is permanent

The ratings labels on iconic 56 Series models that could become detached or unreadable after extended rough use are being replaced with permanent laser engraved ratings. Now the labelling on the all new range 56 Series is going to be as tough as the product.

Look out for the 2009 release of the all new 56 Series.

- Easier switch and socket operation
- Modern contoured profile
- Reduction of potential dirt build-up areas
- Improved strength and reliability
- Three innovative design patents

Index

Cat No	Page
1CB100	34
3S130	40
56AI310	27
56AI315	27
56AI320	27
56AI332	27
56AI416	27
56AI420	27
56AI432	27
56AI440	27
56AI450	27
56AI516	27
56AI520	27
56AI532	27
56AI540	27
56AI550	27
56AM25	40
56BRIDGE	40
56C310EL2P	26
56C310RCD30	25
56C316RCD30	25
56C320RCD30	25
56CB13	34
56CB4	34
56CR310	33
56CR315	33
56CR320	33
56CR332	33
56CR416	33
56CR420	33
56CR432	33
56CR440	33
56CR450	33
56CR516	33
56CR520	33
56CR532	33
56CR540	33
56CR550	33
56CSC310	33
56CSC315	33
56CV310	21
56CV315	21
56CV316/240	22
56CV320	22

Cat No	Page
56CV332	22
56CV416	23
56CV420	23
56CV432	23
56CV440	23
56CV450	23
56CV516	24
56CV520	24
56CV532	24
56CV540	24
56CV550	24
56CV616	24
56CV716	24
56CV720	24
56DIVIDER	40
56DL2	38
56DL4	38
56DL6	38
56E1	36
56E1/25/25	36
56E16	37
56E1S	36
56E2	36
56E2/25/25	36
56E2/40	36
56E2FOOD	36
56E2S	36
56E2V	17, 37
56E3	37
56E4	37
56E4VH	37
56E6	37
56E8	37
56E9	37
56ED2/40	37
56FA1	39
56FA2	39
56FA3	39
56FA4	39
56G1	40
56G2	40
56HPG1	40
56HPG2/1	40
56HPG2/2	40
56LEDK1	11

Cat No	Page
56LEDK3	11
56L1	38
56L1/22/1	35
56L1/22/2	35
56L2	38
56L3	38
56L4	38
56MACTRO	40
56MF	40
56M0500/1	35
56M0500/2	35
56MS230	42
56MS230E	42
56MS230R	42
56MS230SWE	42
56MS230SWR	42
56MS400	42
56MS400E	42
56MS400R	42
56MS400SW	42
56MS400SWE	42
56MS400SWR	42
56MSC230	44
56MSC24	44
56MSC400	44
56P16	40
56P16/20A	40
56P20/250	40
56P20/500	40
56P310	30
56P310R	30
56P315	30
56P32/250	40
56P32/35A	40
56P32/500	40
56P320	30
56P320F	30
56P332	30
56P40	40
56P40/50A	40
56P416	31
56P416K	31
56P420	31
56P432	31



Cat No	Page
56P440	31
56P450	31
56P50	40
56P516	31
56P520	31
56P532	31
56P540	31
56P550	31
56P616	31
56P716	31
56P720	31
56PA16/20A	40
56PA32/35A	40
56PA320	30
56PA332	30
56PA40/50A	40
56PA416	31
56PA416K	31
56PA420	31
56PA432	31
56PA440	31
56PA450	31
56PA516	31
56PA520	31
56PA532	31
56PA540	31
56PA550	31
56PA616	31
56PA716	31
56PA720	31
56PB1/G	14
56PB1/R	14
56PB2G/R	14
56PC	27
56PE2/25	39
56PE2/32	39
56POK	35
56POKI	35
56RCD2030	25
56SHM	35
56S0310	18
56S0310/2	18
56S0310A	18
56S0315	18

Cat No	Page
56S0315A	18
56S0316/110	18
56S0316/240	18
56S0316CEE	20
56S0320	18
56S0320F	18
56S0332	18
56S0332CEE	20
56S0416	19
56S0416CEE	20
56S0416K	19
56S0420	19
56S0432	19
56S0432CCEE	20
56S0432CEE	20
56S0440	19
56S0450	19
56S04ELP15	26
56S0516	19
56S0516CEE	20
56S0520	19
56S0532	19
56S0532CEE	20
56S0540	19
56S0550	19
56S0616	19
56S0716	19
56S0720	19
56SOAUX15	19
56SOCOVER	40
56SOLOCK	19
56SPO310	32
56SPO315	32
56SS10	15, 17
56SW01	11
56SW110	8
56SW110/2	8
56SW110/2I	8
56SW116	9
56SW120	9
56SW120C0	13
56SW132	9
56SW15	11
56SW150	9
56SW210	8
56SW216	9























































Cat No	Page
56SW220	11
56SW232	11
56SW250	11
56SW310	11
56SW316	11
56SW320	11
56SW320C0	13
56SW320FR	13
56SW320KG	12
56SW332	11
56SW332C0	13
56SW332KG	12
56SW340	11
56SW340KG	12
56SW350	11
56SW350/2	11
56SW363/2	11
56SW363KG	12
56SW420KG	12
56SW432KG	12
56SW620KG	12
56T9062	44
56T9092	44
56T9120	44
56T913	44
56T9160	44
56T919	44
56T928	44
56T942	44
56T962	44
56T992	44
56TC24HB	14
56TC7DB	14
56TCU	14
56TD	16
56XDL1	38
648TM	16, 35



Notes

PDL 56 Series™ Product Master Notes

1. 56AI310 suits 56CSC310 only; 56AI315 suits 56CSC315 only
2. 56SPO310 & 56SPO315 RO and RW
3. All CEE17 sockets are available in grey only
4. 56SO432CCEE & matching plug & connector specifically for international container equipment – earth pin position = 3H
5. 56SO416K and matching plugs with a special keyway for dedicated applications where standard products should not be used.

Description	Configuration Female (SO, CV, CR, CSC, SPO)	Ref	Socket Outlet 56SO	Combination Socket Outlet 56CV	Connector 56CR or 56CSC or 56SPO	Configuration Male (P, PA, AI)	Ref	Plug 56P or 56PA	Appliance Inlet 56AI
Ordering Info			GY, RO, RW	GY, RO, RW	Orange/Clear as standard. For RO add V to the stock code (i.e. 56CRV310), except CSC & SPO add RO			Orange/Clear as standard. For RO add V to the stock code (i.e. 56PV310 or 56PAV320). Not available in RW	GY only except 3 pin 10A & 15A available in RO or RW on request
250V									
3 pin (flat) 10A Aust/NZ		A	56S0310 56S0310A	56CV310, 56C310RCD30 56C310EL2P, 56S04ELP15	56CR310, 56CSC310 56SPO310 ²		A	56P310	56AI310 ¹
3 pin (2 flat & round earth) 10A Aust/NZ		B	56S0310R				B	56P310R	
3 pin (flat) 15A Aust/NZ		D	56S0315 56S0315A	56CV315	56CR315, 56CSC315 56SPO315 ²		D	56P315	56AI315 ¹
3 pin (flat) 20A Aust/NZ		E	56S0320F				E	56P320F	
3 pin (round) 20A		F	56S0320	56CV320 56C320RCD30	MACTRO™ 56CR320		f	MACTRO™ 56P320, 56P320QC, 56PA320, 56PA320QC	56AI320
3 pin (round) 32A		G	56S0332	56CV332	56CR332		g	56P332 56PA332	56AI332
500V									
4 pin (round) 16A		H	56S0416	56CV416	MACTRO™ 56CR416		h	MACTRO™ 56P416, 56P416QC, 56PA416, 56PA416QC	56AI416
4 pin (round) 16A high cycle ⁶		I	56S0416K				i	MACTRO™ 56P416K 56PA416K	
4 pin (round) 20A		J	56S0420	56CV420	MACTRO™ 56CR420		j	MACTRO™ 56P420, 56P420QC, 56PA420, 56PA420QC	56AI420
4 pin (round) 32A		K	56S0432	56CV432	56CR432		k	56P432 56PA432	56AI432
4 pin (round) 40A		L	56S0440	56CV440	56CR440		l'	56P440 56PA440	56AI440
4 pin (round) 50A		M	56S0450	56CV450	56CR450		m	56P450 56PA450	56AI450
5 pin (round) 16A		N	56S0516	56CV516	MACTRO™ 56CR516		n	MACTRO™ 56P516, 56P516QC, 56PA516, 56PA516QC	56AI516
5 pin (round) 20A		O	56S0520	56CV520	MACTRO™ 56CR520		o	MACTRO™ 56P520, 56P200QC, 56PA520, 56PA520QC	56AI520
5 pin (round) 32A		P	56S0532	56CV532	56CR532		p	56P532 56PA532	56AI532
5 pin (round) 40A		Q	56S0540	56CV540	56CR540		q	56P540 56PA540	56AI540
5 pin (round) 50A		R	56S0550	56CV550	56CR550		r	56P550 56PA550	56AI550
6 pin (round) 16A		S	56S0616	56CV616			s	MACTRO™ 56P616 56PA616	
7 pin (round) 16A		T	56S0716	56CV716			t	MACTRO™ 56P716 56PA716	
7 pin (round) 20A		U	56S0720	56CV720			u	MACTRO™ 56P720 56PA720	
CEE17³									
110V									
3 pin (round) 16A		V	56S0316/110						
250V									
3 pin (round) 16A		W	56S0316/240, 56S0316CEE	56CV316/240 56C316RCD30	BALS311 BALS31240		W	BALS211 BALS21238	BALS2638
3 pin (round) 32A		X	56S0332CEE		BALS31244		X	BALS21240	
400V									
4 pin (round) 16A		Y	56S0416CEE				Y	BALS21349	
4 pin (round) 32A		Z	56S0432CEE				Z	BALS21351	
4 pin (round) 32A container ⁵		Aa	56S0432CEE		BALS31423		Aa	BALS21485	
5 pin (round) 16A		Bb	56S0516CEE				Bb	BALS21239	
5 pin (round) 32A		Cc	56S0532CEE				Cc	BALS21241	

