

## SPECIFICATIONS

Electrical rating:	230-240V A.C. 50Hz
Load:	10A Resistive 10A Incandescent 6AX Fluorescent
Protection:	IP66 protection
Time selection range:	1 second to 31.5 hours
Operating temperature:	-10 to 40°C maximum

## PRODUCT WARRANTY / 12 MONTHS

The PDL 56TD Time Delay has a 12 month warranty from date of purchase providing the installation of this unit complies with NZECP3 1991 in New Zealand and AS3000 Wiring Rules 1991 in Australia. This warranty covers faulty materials and factory workmanship only and is void on any unit which has been tampered with, damaged by accident, improper operation or incorrect installation. In the event of a warranty claim, the product must be returned to the point of purchase or direct to AUST/NZ Distributors together with proof of purchase.



New Zealand Head Office:  
PO Box 15 355, New Lynn, Auckland, New Zealand  
Telephone +64-9-829 0490, Fax +64-9-829 0491  
www.pdl.co.nz



56TD leaflet.pdf 16 August, 2006



PDL Electrical Products are manufactured by  
Schneider Electric  
Industrial New Zealand  
Teluk Rap, No. 061  
Registered to ISO 9001.



659308



## Electrical Products

PDL Industries Australia Pty Ltd  
Locked Bag 5500, Baulkham Hills Business Centre  
Baulkham Hills NSW 2153 Australia  
Freephone 1300 735 266, Freefax 1300 735 329  
Telephone +61 29851 2666, Fax: +61 29851 2695  
www.pdl.com.au

Rev1



## PDL 56 SERIES TIME DELAY

### Installation and consumer operating instructions for 56TD Time Delay

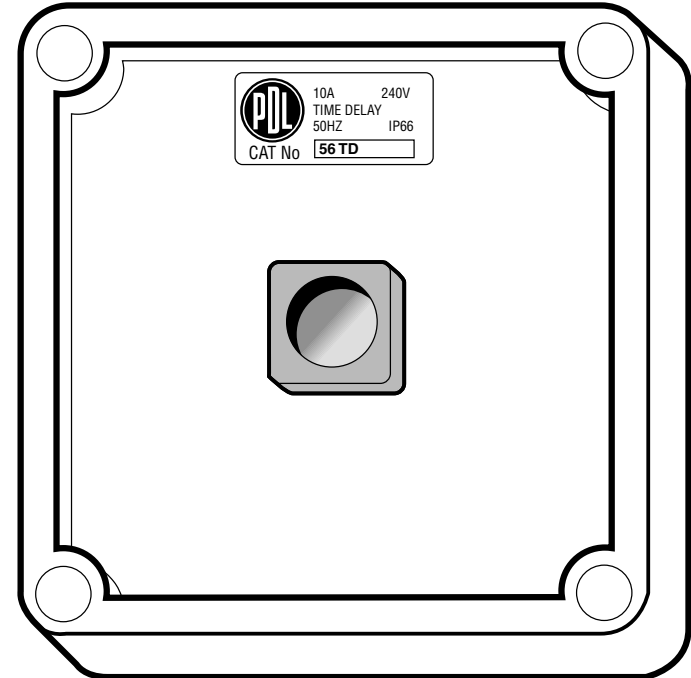

The PDL 56TD Time Delay is an accurate, electronic timing device which allows a load to be switched for a selected time interval.

When the timer's push-button is pressed, power is delivered to the load for a given time period. Time selection options are preset using the 10-way dip switch on the back of the unit. The time selection range is 1 sec. to 31.5 hours.

Brief instructions on how to preset the time interval are shown on the back label. The 'add' and 'multiply' functions are used to calculate the required time.

For popular time settings, a quick setup method is outlined overleaf, while for more detailed step-by-step instructions see page three.

Once the timer has been activated, the power supplied to the load may be interrupted by closing a remotely wired, normally open push button switch (eg PDL Cat 56PB1/R) wired between the 'Active' and 'Remote Reset' terminals. The load will be disconnected from the power supply and the timer reset.

Note: Timer will not activate when power is first applied to the unit until the push button is pressed. If power is lost to the device, the unit will resume in an off position when power is restored.

## QUICK SETUP METHOD FOR POPULAR TIME SETTINGS

The following diagrams depict dip switch configurations for popular time settings. The 1 indicates the down position of the switch toggle. Note that position 1 has no time selection function.

30 sec	<table border="1"><tr><td>1</td><td>2</td><td>3</td><td>4</td><td>5</td><td>6</td><td>7</td><td>8</td><td>9</td><td>10</td></tr><tr><td></td><td>1</td><td></td><td></td><td></td><td></td><td></td><td></td><td></td><td>1</td></tr><tr><td>X</td><td>S</td><td>1</td><td>1</td><td>32</td><td>16</td><td>8</td><td>4</td><td>2</td><td>1</td></tr><tr><td>X</td><td>M</td><td>10</td><td>3</td><td>0</td><td>0</td><td>0</td><td>0</td><td>0</td><td>0</td></tr><tr><td></td><td></td><td>1</td><td>1</td><td>1</td><td>1</td><td>1</td><td>1</td><td>1</td><td>1</td></tr></table>	1	2	3	4	5	6	7	8	9	10		1								1	X	S	1	1	32	16	8	4	2	1	X	M	10	3	0	0	0	0	0	0			1	1	1	1	1	1	1	1	15 min	<table border="1"><tr><td>1</td><td>2</td><td>3</td><td>4</td><td>5</td><td>6</td><td>7</td><td>8</td><td>9</td><td>10</td></tr><tr><td></td><td></td><td></td><td></td><td></td><td></td><td></td><td>1</td><td></td><td>1</td></tr><tr><td>X</td><td>S</td><td>1</td><td>1</td><td>32</td><td>16</td><td>8</td><td>4</td><td>2</td><td>1</td></tr><tr><td>X</td><td>M</td><td>10</td><td>3</td><td>0</td><td>0</td><td>0</td><td>0</td><td>0</td><td>0</td></tr><tr><td></td><td></td><td>1</td><td>1</td><td>1</td><td>1</td><td>1</td><td>1</td><td>1</td><td>1</td></tr></table>	1	2	3	4	5	6	7	8	9	10								1		1	X	S	1	1	32	16	8	4	2	1	X	M	10	3	0	0	0	0	0	0			1	1	1	1	1	1	1	1	5 hr	<table border="1"><tr><td>1</td><td>2</td><td>3</td><td>4</td><td>5</td><td>6</td><td>7</td><td>8</td><td>9</td><td>10</td></tr><tr><td></td><td></td><td></td><td></td><td></td><td></td><td></td><td></td><td>1</td><td>1</td></tr><tr><td>X</td><td>S</td><td>1</td><td>1</td><td>32</td><td>16</td><td>8</td><td>4</td><td>2</td><td>1</td></tr><tr><td>X</td><td>M</td><td>10</td><td>3</td><td>0</td><td>0</td><td>0</td><td>0</td><td>0</td><td>0</td></tr><tr><td></td><td></td><td>1</td><td>1</td><td>1</td><td>1</td><td>1</td><td>1</td><td>1</td><td>1</td></tr></table>	1	2	3	4	5	6	7	8	9	10									1	1	X	S	1	1	32	16	8	4	2	1	X	M	10	3	0	0	0	0	0	0			1	1	1	1	1	1	1	1
1	2	3	4	5	6	7	8	9	10																																																																																																																																																		
	1								1																																																																																																																																																		
X	S	1	1	32	16	8	4	2	1																																																																																																																																																		
X	M	10	3	0	0	0	0	0	0																																																																																																																																																		
		1	1	1	1	1	1	1	1																																																																																																																																																		
1	2	3	4	5	6	7	8	9	10																																																																																																																																																		
							1		1																																																																																																																																																		
X	S	1	1	32	16	8	4	2	1																																																																																																																																																		
X	M	10	3	0	0	0	0	0	0																																																																																																																																																		
		1	1	1	1	1	1	1	1																																																																																																																																																		
1	2	3	4	5	6	7	8	9	10																																																																																																																																																		
								1	1																																																																																																																																																		
X	S	1	1	32	16	8	4	2	1																																																																																																																																																		
X	M	10	3	0	0	0	0	0	0																																																																																																																																																		
		1	1	1	1	1	1	1	1																																																																																																																																																		
1 min	<table border="1"><tr><td>1</td><td>2</td><td>3</td><td>4</td><td>5</td><td>6</td><td>7</td><td>8</td><td>9</td><td>10</td></tr><tr><td></td><td>1</td><td></td><td></td><td></td><td></td><td></td><td></td><td></td><td>1</td></tr><tr><td>X</td><td>S</td><td>1</td><td>1</td><td>32</td><td>16</td><td>8</td><td>4</td><td>2</td><td>1</td></tr><tr><td>X</td><td>M</td><td>10</td><td>3</td><td>0</td><td>0</td><td>0</td><td>0</td><td>0</td><td>0</td></tr><tr><td></td><td></td><td>1</td><td>1</td><td>1</td><td>1</td><td>1</td><td>1</td><td>1</td><td>1</td></tr></table>	1	2	3	4	5	6	7	8	9	10		1								1	X	S	1	1	32	16	8	4	2	1	X	M	10	3	0	0	0	0	0	0			1	1	1	1	1	1	1	1	30 min	<table border="1"><tr><td>1</td><td>2</td><td>3</td><td>4</td><td>5</td><td>6</td><td>7</td><td>8</td><td>9</td><td>10</td></tr><tr><td></td><td></td><td></td><td></td><td></td><td></td><td></td><td></td><td></td><td>1</td></tr><tr><td>X</td><td>S</td><td>1</td><td>1</td><td>32</td><td>16</td><td>8</td><td>4</td><td>2</td><td>1</td></tr><tr><td>X</td><td>M</td><td>10</td><td>3</td><td>0</td><td>0</td><td>0</td><td>0</td><td>0</td><td>0</td></tr><tr><td></td><td></td><td>1</td><td>1</td><td>1</td><td>1</td><td>1</td><td>1</td><td>1</td><td>1</td></tr></table>	1	2	3	4	5	6	7	8	9	10										1	X	S	1	1	32	16	8	4	2	1	X	M	10	3	0	0	0	0	0	0			1	1	1	1	1	1	1	1	10 hr	<table border="1"><tr><td>1</td><td>2</td><td>3</td><td>4</td><td>5</td><td>6</td><td>7</td><td>8</td><td>9</td><td>10</td></tr><tr><td></td><td></td><td></td><td></td><td></td><td></td><td></td><td></td><td>1</td><td>1</td></tr><tr><td>X</td><td>S</td><td>1</td><td>1</td><td>32</td><td>16</td><td>8</td><td>4</td><td>2</td><td>1</td></tr><tr><td>X</td><td>M</td><td>10</td><td>3</td><td>0</td><td>0</td><td>0</td><td>0</td><td>0</td><td>0</td></tr><tr><td></td><td></td><td>1</td><td>1</td><td>1</td><td>1</td><td>1</td><td>1</td><td>1</td><td>1</td></tr></table>	1	2	3	4	5	6	7	8	9	10									1	1	X	S	1	1	32	16	8	4	2	1	X	M	10	3	0	0	0	0	0	0			1	1	1	1	1	1	1	1
1	2	3	4	5	6	7	8	9	10																																																																																																																																																		
	1								1																																																																																																																																																		
X	S	1	1	32	16	8	4	2	1																																																																																																																																																		
X	M	10	3	0	0	0	0	0	0																																																																																																																																																		
		1	1	1	1	1	1	1	1																																																																																																																																																		
1	2	3	4	5	6	7	8	9	10																																																																																																																																																		
									1																																																																																																																																																		
X	S	1	1	32	16	8	4	2	1																																																																																																																																																		
X	M	10	3	0	0	0	0	0	0																																																																																																																																																		
		1	1	1	1	1	1	1	1																																																																																																																																																		
1	2	3	4	5	6	7	8	9	10																																																																																																																																																		
								1	1																																																																																																																																																		
X	S	1	1	32	16	8	4	2	1																																																																																																																																																		
X	M	10	3	0	0	0	0	0	0																																																																																																																																																		
		1	1	1	1	1	1	1	1																																																																																																																																																		
2 min	<table border="1"><tr><td>1</td><td>2</td><td>3</td><td>4</td><td>5</td><td>6</td><td>7</td><td>8</td><td>9</td><td>10</td></tr><tr><td></td><td>1</td><td></td><td></td><td></td><td></td><td></td><td></td><td></td><td>1</td></tr><tr><td>X</td><td>S</td><td>1</td><td>1</td><td>32</td><td>16</td><td>8</td><td>4</td><td>2</td><td>1</td></tr><tr><td>X</td><td>M</td><td>10</td><td>3</td><td>0</td><td>0</td><td>0</td><td>0</td><td>0</td><td>0</td></tr><tr><td></td><td></td><td>1</td><td>1</td><td>1</td><td>1</td><td>1</td><td>1</td><td>1</td><td>1</td></tr></table>	1	2	3	4	5	6	7	8	9	10		1								1	X	S	1	1	32	16	8	4	2	1	X	M	10	3	0	0	0	0	0	0			1	1	1	1	1	1	1	1	1 hr	<table border="1"><tr><td>1</td><td>2</td><td>3</td><td>4</td><td>5</td><td>6</td><td>7</td><td>8</td><td>9</td><td>10</td></tr><tr><td></td><td></td><td></td><td></td><td></td><td></td><td></td><td></td><td></td><td>1</td></tr><tr><td>X</td><td>S</td><td>1</td><td>1</td><td>32</td><td>16</td><td>8</td><td>4</td><td>2</td><td>1</td></tr><tr><td>X</td><td>M</td><td>10</td><td>3</td><td>0</td><td>0</td><td>0</td><td>0</td><td>0</td><td>0</td></tr><tr><td></td><td></td><td>1</td><td>1</td><td>1</td><td>1</td><td>1</td><td>1</td><td>1</td><td>1</td></tr></table>	1	2	3	4	5	6	7	8	9	10										1	X	S	1	1	32	16	8	4	2	1	X	M	10	3	0	0	0	0	0	0			1	1	1	1	1	1	1	1	12 hr	<table border="1"><tr><td>1</td><td>2</td><td>3</td><td>4</td><td>5</td><td>6</td><td>7</td><td>8</td><td>9</td><td>10</td></tr><tr><td></td><td></td><td></td><td></td><td></td><td></td><td></td><td></td><td>1</td><td>1</td></tr><tr><td>X</td><td>S</td><td>1</td><td>1</td><td>32</td><td>16</td><td>8</td><td>4</td><td>2</td><td>1</td></tr><tr><td>X</td><td>M</td><td>10</td><td>3</td><td>0</td><td>0</td><td>0</td><td>0</td><td>0</td><td>0</td></tr><tr><td></td><td></td><td>1</td><td>1</td><td>1</td><td>1</td><td>1</td><td>1</td><td>1</td><td>1</td></tr></table>	1	2	3	4	5	6	7	8	9	10									1	1	X	S	1	1	32	16	8	4	2	1	X	M	10	3	0	0	0	0	0	0			1	1	1	1	1	1	1	1
1	2	3	4	5	6	7	8	9	10																																																																																																																																																		
	1								1																																																																																																																																																		
X	S	1	1	32	16	8	4	2	1																																																																																																																																																		
X	M	10	3	0	0	0	0	0	0																																																																																																																																																		
		1	1	1	1	1	1	1	1																																																																																																																																																		
1	2	3	4	5	6	7	8	9	10																																																																																																																																																		
									1																																																																																																																																																		
X	S	1	1	32	16	8	4	2	1																																																																																																																																																		
X	M	10	3	0	0	0	0	0	0																																																																																																																																																		
		1	1	1	1	1	1	1	1																																																																																																																																																		
1	2	3	4	5	6	7	8	9	10																																																																																																																																																		
								1	1																																																																																																																																																		
X	S	1	1	32	16	8	4	2	1																																																																																																																																																		
X	M	10	3	0	0	0	0	0	0																																																																																																																																																		
		1	1	1	1	1	1	1	1																																																																																																																																																		
5 min	<table border="1"><tr><td>1</td><td>2</td><td>3</td><td>4</td><td>5</td><td>6</td><td>7</td><td>8</td><td>9</td><td>10</td></tr><tr><td></td><td>1</td><td></td><td></td><td></td><td></td><td></td><td></td><td></td><td>1</td></tr><tr><td>X</td><td>S</td><td>1</td><td>1</td><td>32</td><td>16</td><td>8</td><td>4</td><td>2</td><td>1</td></tr><tr><td>X</td><td>M</td><td>10</td><td>3</td><td>0</td><td>0</td><td>0</td><td>0</td><td>0</td><td>0</td></tr><tr><td></td><td></td><td>1</td><td>1</td><td>1</td><td>1</td><td>1</td><td>1</td><td>1</td><td>1</td></tr></table>	1	2	3	4	5	6	7	8	9	10		1								1	X	S	1	1	32	16	8	4	2	1	X	M	10	3	0	0	0	0	0	0			1	1	1	1	1	1	1	1	2 hr	<table border="1"><tr><td>1</td><td>2</td><td>3</td><td>4</td><td>5</td><td>6</td><td>7</td><td>8</td><td>9</td><td>10</td></tr><tr><td></td><td></td><td></td><td></td><td></td><td></td><td></td><td></td><td></td><td>1</td></tr><tr><td>X</td><td>S</td><td>1</td><td>1</td><td>32</td><td>16</td><td>8</td><td>4</td><td>2</td><td>1</td></tr><tr><td>X</td><td>M</td><td>10</td><td>3</td><td>0</td><td>0</td><td>0</td><td>0</td><td>0</td><td>0</td></tr><tr><td></td><td></td><td>1</td><td>1</td><td>1</td><td>1</td><td>1</td><td>1</td><td>1</td><td>1</td></tr></table>	1	2	3	4	5	6	7	8	9	10										1	X	S	1	1	32	16	8	4	2	1	X	M	10	3	0	0	0	0	0	0			1	1	1	1	1	1	1	1	24 hr	<table border="1"><tr><td>1</td><td>2</td><td>3</td><td>4</td><td>5</td><td>6</td><td>7</td><td>8</td><td>9</td><td>10</td></tr><tr><td></td><td></td><td></td><td></td><td></td><td></td><td></td><td></td><td></td><td>1</td></tr><tr><td>X</td><td>S</td><td>1</td><td>1</td><td>32</td><td>16</td><td>8</td><td>4</td><td>2</td><td>1</td></tr><tr><td>X</td><td>M</td><td>10</td><td>3</td><td>0</td><td>0</td><td>0</td><td>0</td><td>0</td><td>0</td></tr><tr><td></td><td></td><td>1</td><td>1</td><td>1</td><td>1</td><td>1</td><td>1</td><td>1</td><td>1</td></tr></table>	1	2	3	4	5	6	7	8	9	10										1	X	S	1	1	32	16	8	4	2	1	X	M	10	3	0	0	0	0	0	0			1	1	1	1	1	1	1	1
1	2	3	4	5	6	7	8	9	10																																																																																																																																																		
	1								1																																																																																																																																																		
X	S	1	1	32	16	8	4	2	1																																																																																																																																																		
X	M	10	3	0	0	0	0	0	0																																																																																																																																																		
		1	1	1	1	1	1	1	1																																																																																																																																																		
1	2	3	4	5	6	7	8	9	10																																																																																																																																																		
									1																																																																																																																																																		
X	S	1	1	32	16	8	4	2	1																																																																																																																																																		
X	M	10	3	0	0	0	0	0	0																																																																																																																																																		
		1	1	1	1	1	1	1	1																																																																																																																																																		
1	2	3	4	5	6	7	8	9	10																																																																																																																																																		
									1																																																																																																																																																		
X	S	1	1	32	16	8	4	2	1																																																																																																																																																		
X	M	10	3	0	0	0	0	0	0																																																																																																																																																		
		1	1	1	1	1	1	1	1																																																																																																																																																		

## INSTALLATION INSTRUCTIONS

Before wiring, ensure the supply is disconnected at the distribution board and study the wiring diagram before terminating wires. Do not connect Active to any terminal other than indicated on the diagram and on the product.

### 56TD Wiring Diagram

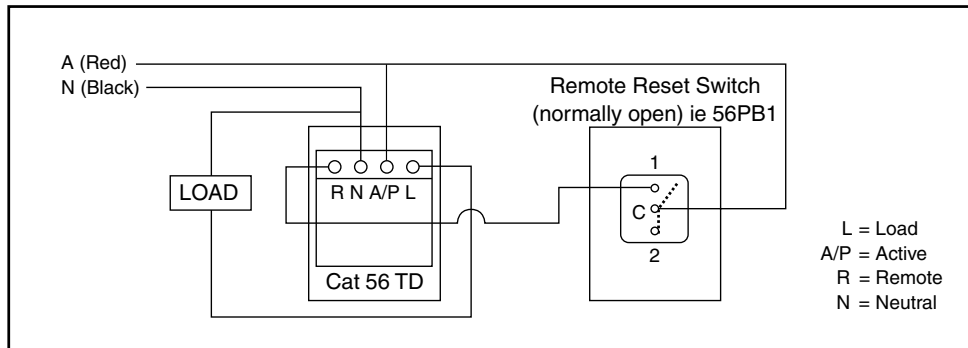

## BASIC THREE-STEP SETUP METHOD

### Step 1:

For time of 31 min 30 sec or less set switch 2 @ S (secs) and convert the time required into seconds (eg 2 minutes = 120 seconds) ..... (go to Step 2/S)  
For times of 31 min 31 sec or more set switch 2 @ M (min) and convert the time required into minutes (eg 2 hours = 120 minutes) ..... (go to Step 2/M)

EXAMPLE

Switch #	1	2	3	4	5	6	7	8	9	10
X		1								
S		1	1	32	16	8	4	2	1	
M		10	3	0	0	0	0	0	0	

S = seconds

### Step 2/S:

1 second - 63 seconds set switch 3 @ 01 and switch 4 @ 01 ..... (go to 3-A)  
64 seconds - 189 seconds set switch 3 @ 01 and switch 4 @ 03 ..... (go to 3-B)  
190 seconds - 630 seconds set switch 3 @ 10 and switch 4 @ 01 ..... (go to 3-C)  
631 seconds - 1890 seconds set switch 3 @ 10 and switch 4 @ 03 ..... (go to 3-D)

EXAMPLE

Switch #	1	2	3	4	5	6	7	8	9	10
X			1	1						
S			1	1	32	16				
M			10	3	0	0				

Switch 3 @ 01  
Switch 4 @ 03

### Step 2/M:

1 minute - 63 minutes set switch 3 @ 01 and switch 4 @ 01 ..... (go to 3-E)  
64 minutes - 189 minutes set switch 3 @ 01 and switch 4 @ 03 ..... (go to 3-F)  
190 minutes - 630 minutes set switch 3 @ 10 and switch 4 @ 01 ..... (go to 3-G)  
631 minutes - 1890 minutes set switch 3 @ 10 and switch 4 @ 03 ..... (go to 3-H)

EXAMPLE

Switch #	1	2	3	4	5	6	7	8	9	10
X					1		1		1	
S					32	16	8	4	2	1
M					10	3	0	0	0	0

0 + 16 + 0 + 4 + 0 + 1 = 21

**Step 3:** Set switches 5 through 10 so that added together their value =

- 3A = the seconds required ..... (selection is complete)
- 3B = the seconds required divided by 3 ..... (selection is complete)
- 3C = the seconds required divided by 10 ..... (selection is complete)
- 3D = the seconds required divided by 30 ..... (selection is complete)
- 3E = the minutes required ..... (selection is complete)
- 3F = the minutes required divided by 3 ..... (selection is complete)
- 3G = the minutes required divided by 10 ..... (selection is complete)
- 3H = the minutes required divided by 30 ..... (selection is complete)