



Repairing GIB® Plasterboard & Mounting Fixtures



This guide gives instructions for repairing plasterboard and mounting fixtures in non fire-rated walls and ceilings.

Introduction

Plasterboard repairs are necessary for a number of reasons. Whether it's careless movers wielding appliances, a door opened too quickly and the handle has gone through the wall, kids hustling through the house or just natural settling of the house, holes and cracks can appear in plasterboard.

Cracks are normally the result of movement of a building. A common example of this is when joints are made at the high stress points above and/or below the corners of windows and doors. If you own a new building and notice these cracks forming, it is suggested you leave these for approximately 1 year before repairing. This allows the building to settle and should reduce the likelihood of problems recurring, but is no guarantee the same problems will not occur.

This leaflet has been designed to give you some useful pointers when repairing dings and holes in GIB® Plasterboard. In addition it also covers the mounting of fixtures to GIB® Plasterboard when fixing into a stud with screws or nails is not possible.

Note: The instructions given in the leaflet are **NOT** suitable when conducting repairs to fire-rated walls. Similarly mounting fixtures in fire-rated walls **MUST BE AVOIDED** as this will affect the performance of the fire rated system.

Stopping plasterboard is a task that requires some practise and skill. As a result you should consider the services of an experienced tradesman when conducting repairs. Not only will they achieve a better finish, which is important when painting walls, but they will finish the job more quickly and with less fuss.

Repairing GIB® Plasterboard

Tools

Some or all of the following tools will be required depending on the actual work being carried out.

- Rubber spatula, or similar for mixing plaster
- Plastic Bowl
- 150 mm Broad Knife
- Sanding Block
- Sharp Craft Knife
- 280 mm Trowel

All tools should be clean and free of any old and set plaster. It is recommended that stainless steel tools be purchased if possible as these are less likely to corrode.

Tip: A light spray with CRC, or similar, and a wipe with a cloth or paper towel will also help keep metal tools in the best condition.

Remember that as these tools, such as broad-knives, are being used to create a smooth finish, any kinks or scratches in the edge of the tool will cause rough areas in the plaster. Do not use broad-knives for scraping, opening paint cans, etc.

Materials

Plasterboard

Occasionally a plasterboard patch will be required to repair a damaged wall. As often only a small section is required, it is suggested that you contact a local builder or plasterboard stopper for an off-cut.

Compound

Only two compounds are required to effect the different types of repairs outlined in this leaflet.

GIB Tradeset® 20

GIB Tradeset® 20 is a powder compound that when mixed with water sets hard in approximately 20-40 minutes. Complete drying may take a further 24 hours depending on how thick the compound is applied. GIB Tradeset® 20 is available in 5 kg and 20 kg bags.

The product should be mixed using the following instructions.

1. Place a small amount of clean tap water in a mixing bowl. For best results the water should be at room temperature and greater than 10°C.
2. For every 300 mL of water sprinkle approximately 500 g of plaster into the water.

Tip: As a guide when mixing powder compounds, sprinkle in just enough powder until the water no longer soaks through. If water soaks through, sprinkle in a little more powder.

Tip: It is preferable to mix the compound too thick than too thin. It is easier to add water than to add powder.

3. Leave the mixture to soak for approximately 30 seconds.
4. Mix using a rubber spatula or similar for approximately 90 seconds until the mixture is smooth and lump free.

Note: It is recommended that **GIB Tradeset® 20** is used in all cases where it is mentioned in these projects. This product is easily mixed prior to use. While the temptation may be to use an off-the-shelf pre-mixed plaster compound for convenience, caution needs to be taken. Some pre-mixed products shrink upon drying and can crack within a few weeks making your repair work look poor.

GIB Plus 4®

GIB Plus 4® is a pre-mixed compound that comes in a pail ready to use. A light mixing of the compound once it has been opened is all that is required. GIB Plus 4® is available in 4, 10 and 15 litre pails.

Note: Always carefully read the instructions on the bag or pail before beginning.

Drying Time

Joint compound must be allowed to dry before it is painted. It is not acceptable practise to plaster a hole or wall and paint over it almost immediately.

Approximate drying times for pre-mixed compounds can be found on the back of the pail, but typically these should be left for a minimum of 24 hours between coats, and longer if the conditions are cold and/or damp.

For best results it is recommended that water, air and mix temperatures be kept above 10°C.

Storage

Many of the problems that occur with joint compounds result from incorrect storage of the product. Correctly store the material as stated on the packaging and don't use after the use-by-date indicated on the packaging.

Pre-mixed compounds must not be allowed to freeze.

Tip: Buy only as much product as is necessary to complete the work you will be doing.

Clean Up

Leave any spilt material to harden before scraping up and disposing of to landfill. A little warm water on a cloth is normally sufficient to remove any residue.

Repairing Dings, Cracks & Scratches

The following procedure should be used for repairing dings, cracks and scratches which are less than 3 mm deep.

1. Sand the area around the repair to ensure the best adhesion between the compound and the painted surface.
2. Using a broad-knife apply GIB Plus 4® to the damaged area.

Tip: Generally speaking the flatter a trowel or broad-knife is held to the board surface the more compound will be applied. The closer to perpendicular the trowel or broad-knife is held the more compound will be removed.

3. Leave the compound to dry. Generally 24 hours for areas up to 1 mm thick and 48 hours for those areas which are thicker than this.
4. Sand the area with 220 grit sandpaper or finer. Sand in one direction, not in a circular motion.

Tip: A dust free alternative is to wipe the area smooth using a damp sponge. The compound should then be left to dry for a further 2 hours prior to decorating. This technique is known as 'wet sanding'.

5. Decorate as required.

Tip: Many paint shops can match paint colours using a sample of the existing paint. Remove a section prior to repair so that this area can be encompassed in the repair.

Repairing Small Holes

For small holes less than 50 mm in diameter a self-adhesive patch provides a quick and professional looking repair.

1. Sand the area around the repair to ensure the best adhesion between the compound and the painted surface.
2. Apply the self-adhesive patch over the area.
3. Mix a small amount of GIB Tradeset® 20.
4. Apply the compound over the patch using a broad knife.
5. Leave the compound to set and dry for approximately 24 hours.
6. Scrape back any raised or rough areas using a broad knife or sandpaper.

Tip: For a better finish, apply a thin coat of finishing compound, such as GIB Plus 4® and sand or 'wet sand' before decorating.

7. Decorate as required.

Repairing Medium Holes

For holes between 50 and 150 mm in diameter a plasterboard patch will be required.

1. Cut away the damaged area to a neat rectangular hole.
2. Sand the area around the repair to ensure the best adhesion between the compound and the painted surface.
3. Cut a piece of plasterboard that is slightly longer (approximately 20 mm) than the hole, but small enough to fit through the hole.

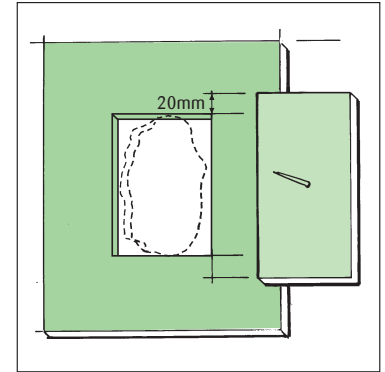

4. Place a 60 mm flat head nail through the centre of the piece of plasterboard and coat the ends with GIB Tradeset® 20.
5. Insert the patch into the hole.

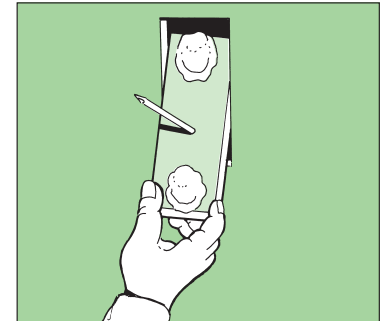

6. Pull toward the front using the nail.
7. Once hard (approximately 1 hr) gently push the nail back through the patch.
8. Using a broad knife fill the hole flush to the surrounding area with GIB Tradeset® 20.
9. Leave to dry for approximately 48-72 hours. This longer time is required because the plaster is being applied very thick.
10. Apply a thin coat of GIB Plus 4® over the patched area.
11. Leave to dry and sand or wet sand the area smooth.
12. Decorate the area as required.

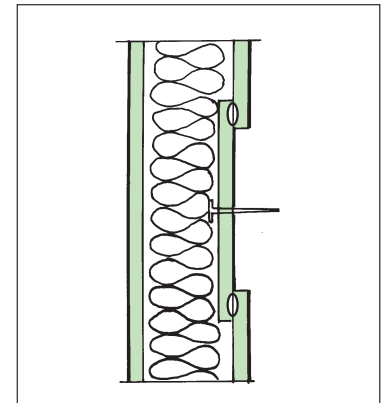

Repairing Large Holes

For larger holes it becomes necessary to cut away the damaged area back to one or two studs and use a plasterboard patch.

1. Cut away the damaged area to either one or both studs surrounding the damage to form a rectangular hole.
2. Sand the area around the repair to ensure the best adhesion between the compound and painted surface.
3. Cut a length of plasterboard that is 100 mm wide and 100 mm longer than the height of the hole.

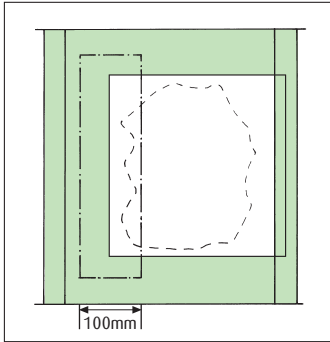

Tip: If you have cut away to both studs this will not be required. Fixing to both studs is the easier method of repair, but is not always possible.

4. Using GIB Tradeset® 20 fix the plasterboard to the side of the hole which is not made over the stud.
5. Cut a new piece of GIB® Plasterboard to fit the hole and fix this to the stud(s) and/or plasterboard back-block.
6. Apply a coat of GIB Tradeset® 20 over the four joints using a broad knife.
7. Immediately place a length of paper jointing tape into the compound using the broad knife to remove any air bubbles under the tape.

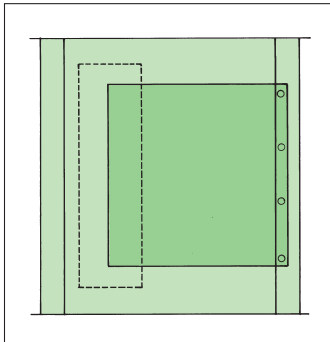

Tip: If any blisters appear in the tape this is usually an indicator that insufficient compound is present behind the tape. Simply lift the area of tape away using the corner of the broad-knife, apply a small amount of compound and press the tape back into the compound once more.

8. Once the first coat is hard apply a second coat of GIB Tradeset® 20 over the joint areas, feathering the edges, so that it is approximately 250 mm wide.
9. Leave the compound to dry for 24 hours.
10. Scrape away any rough edges using a broad knife.
11. Apply a thin coat of GIB Plus 4® over the patched area.
12. Leave to dry and sand or wet sand the area smooth.
13. Decorate the area as required.

Mounting Fixtures to GIB® Plasterboard

Tools

Some or all of the following tools will be required depending on the actual work being carried out.

- Drill and bits
- Screw Driver

Systems

The following systems can be used in GIB® Plasterboard walls that are not fire-rated. They are suitable for fixing lightweight items such as pictures, coat hooks and fire extinguishers (up to 20kg), etc. in situations where fixing into the stud with nails or screws is not possible.

These systems are **NOT** suitable for heavy items such as shelving, cupboards or vanity units which require additional framing for support.

The fixing method depends on the thickness of the GIB® Plasterboard and the distance that the fixture hangs out from the wall. The following guidelines are indicative only, consult the fixing manufacturer or distributor if you are in any doubt. **The capacities below are given for 10mm GIB® Standard Plasterboard.**

Allowable Fixture Weight	System Diagram
15 - 20kg	
8kg	

Allowable Fixture Weight	System Diagram
6 - 8kg	
3kg	

1.5mm min diameter nail

The first system has the highest pull-out capacity i.e. requires more force or weight to pull it from the wall. This system should be used for fixtures that do not hang flat with the wall.

Note: Whilst the advice and recommendations contained in this brochure have been produced with proper care, they are offered only with the object of assisting those interested in or involved with the fixing of plasterboard. Winstone Wallboards Ltd and BRANZ do not accept liability for the advice, recommendations, etc, contained herein.



GIB® Helpline:
 Free-Phone 0800 100 442
 Free-Fax 0800 229 222
 E-mail info@gib.co.nz
 Web www.gib.co.nz

