

Product Technical Statement

Gerard Roofs Pressed Steel Tiles

Statement of Building Code Compliance

This system if designed, used, installed and maintained in accordance with the supporting technical information and additional conditions and limitations will meet the following provisions of the New Zealand Building Code:

- B1 Structure
- B2 Durability
- E1 Surface Water
- E2 External Moisture

Evidence Base to Support Compliance

This system has the following evidence to support the above solution type declaration:

- Independent technical opinion
- In-house technical opinion
- Independent testing
- In-house testing
- Industry-based scheme
- Historical proof of performance

B1, B2, E1 & E2 reference NZ Metal Roofing & Wall Cladding Manufacturers Code of Practice. Section 10 relates to Pressed Metal Roofing Tiles.

Compliance with NZS4217 Pressed Metal Tile Roofs

Aluminium-zinc coated steel complies with AS1397, not NZS3441 as prescribed in NZS4217. We are also comfortable that we meet the requirements of B2 based on the In-service History Evaluation allowed under B2/VM1. At two severe marine testing sites we have roofs which are in good condition after 23 and 25 years respectively. Evaluations continue on other roofs which are in excess of 30 years.

Scope of Use

Buildings that comply with NZS3604 with a minimum roof pitch which is profile dependent of between 12 and 20 degrees.

Environmental Conditions

This system is code-compliant for the following environmental conditions:

- Wind Zone - Specific Design
- Corrosion Zone - Sea Spray Extreme
- Seismic Zone - High

Specific design can allow higher wind speeds - batten rafter connections are the limitation.

Installation Conditions

This system is code-compliant on the condition that it has been installed by:

- Licensed Applicator / Installer

Additional Conditions & Limitations

A warranty for the system is supplied with 50 year pro-rated duration.

Material Compatibility with Modern Roofing Materials

If alterations are made to the home after the installation of the roof, such as fitting of chimneys, extensions, installation of skylights, etc., it is important to ensure that the materials that are used are compatible with the roofing material. Gerard Roofs' steel tiles are manufactured from 55% aluminium- zinc coated steel and then post coated with a protective and decorative coating system.

Dissimilar Metal Corrosion

When two different metals are in contact and moisture is present, one metal is relatively protected while the other suffers accelerated corrosion. A similar effect commonly occurs with water flowing over dissimilar metals. This form of corrosion is commonly found where:

- Water is discharged from copper or brass systems over a galvanised or 55% aluminium-zinc coated steel roof
- Unpainted lead flashings are applied directly to 55% aluminium-zinc coated steel products, or
- Where fasteners are incompatible with the roofing material

Any electrical contact between dissimilar metals should be avoided.

Consenting Instructions

Where Gerard Metal Roofing Tiles are specified on plans these must be installed by a trained installer. Substitution is not allowed.

Critical Maintenance

As detailed in our warranty: "It is best to chemically clean the roof before growths are seen as a preventative maintenance measure. Spores may be present on the roof for up to two years before any visible organic growths are noticed. Treating the roof will not only kill the organic growths, but also the spores that lead to them. We suggest treating the roof every three to five years, however if you see growth occurring treat the roof more frequently."

Gerard Corona

Specific Installation Instructions

Roof pitch	15-90°
Overall length	1320 mm
Length of cover	1250 mm
Width of cover	370 mm
Upstand	27 mm
Roof cover/panel	0.46 m ²
Coverage	2.2 panel/m ²
Textured unit weight	3.0 kg
Satin unit weight	2.1 kg

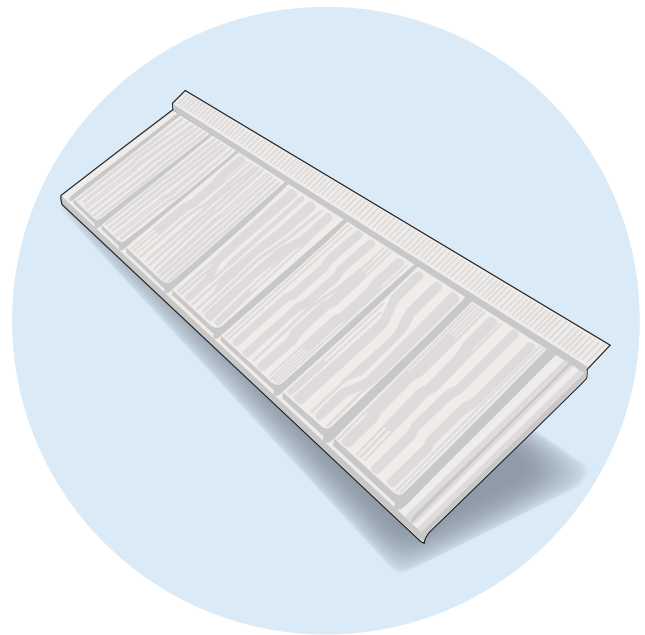

Dimensions and weights given are nominal.

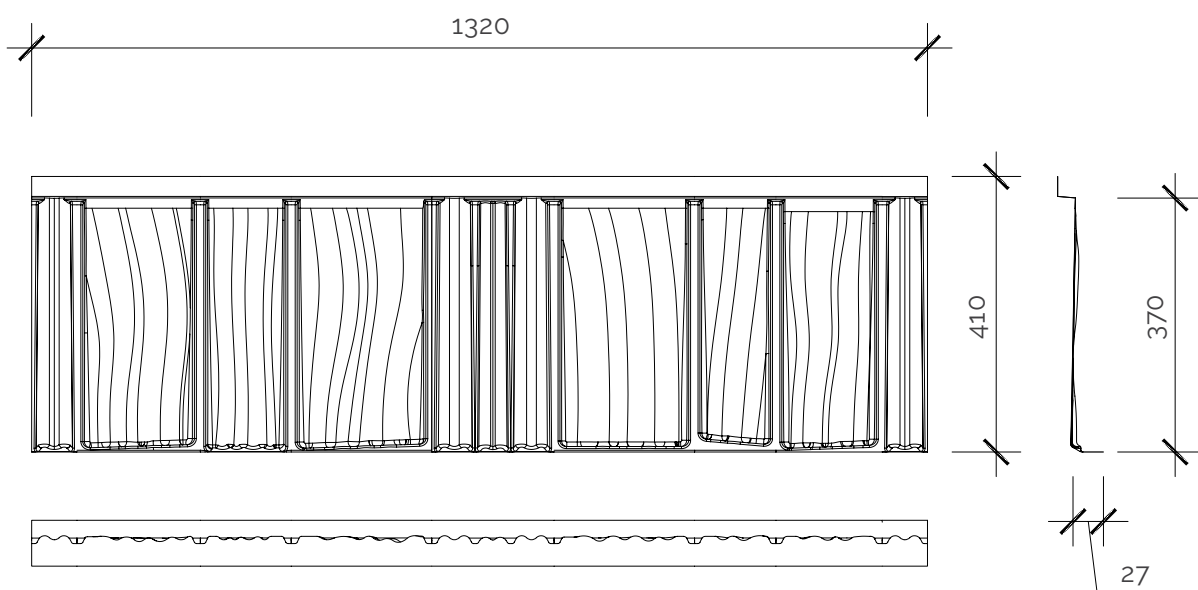

The worry-proof roof.®

Gerard Corona Panel Installation – Nailing Position

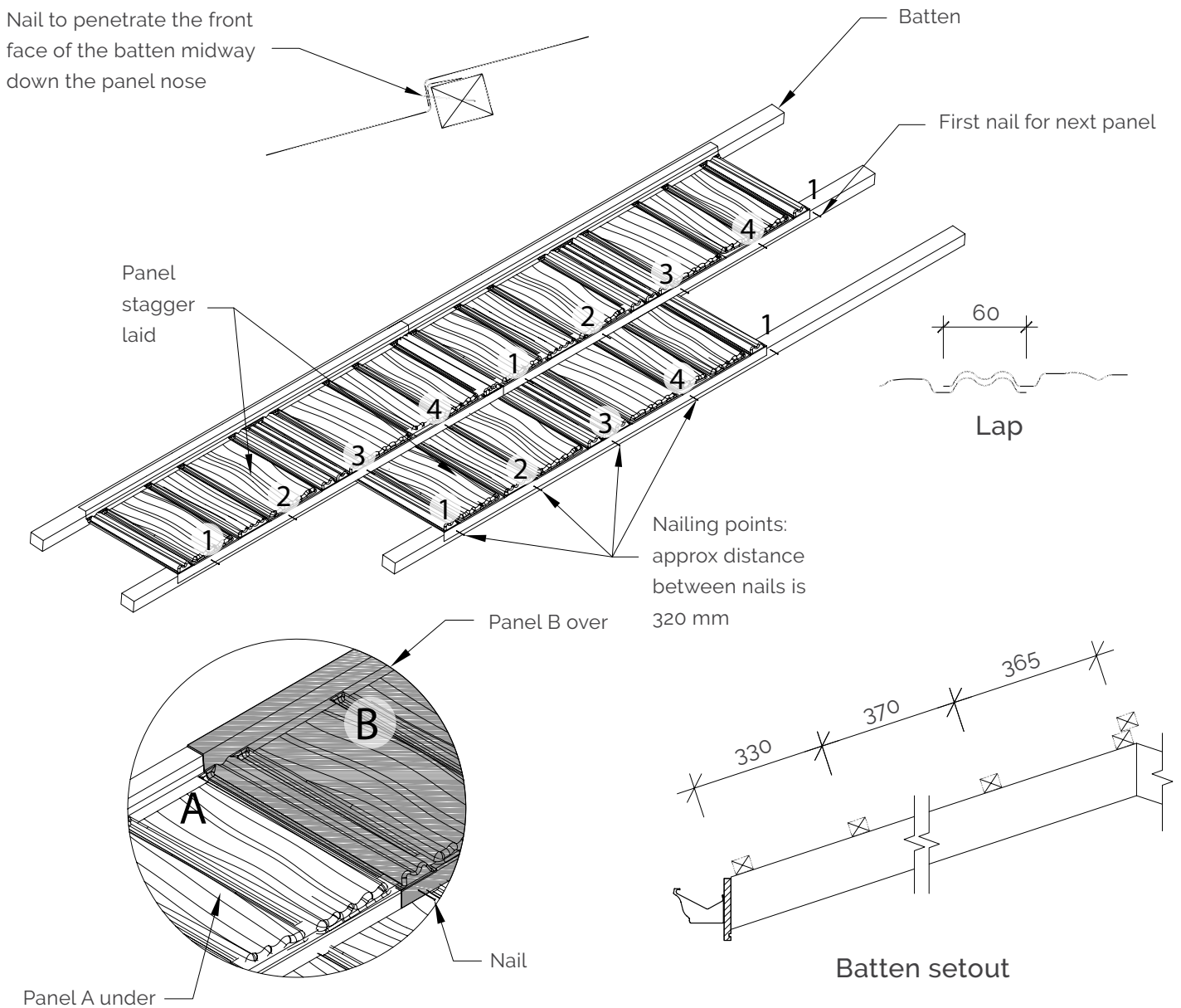

Fixing

- The nose of each panel is held down at 5 points.
- This comprises 4 nails as per the diagrams plus the nailed overlap panel.

Fastening panels in Cyclone Areas

- Where a building has been designed outside the scope of NZS 3604. Panels on buildings with a wind load design of above 3.8 kPa should be fastened at approx 160 mm spacing (each module).

Gerard Senator

Specific Installation Instructions

Roof pitch	15-90°
Overall length	1320 mm
Length of cover	1250 mm
Width of cover	368 mm
Upstand	16 mm
Roof cover/panel	0.46 m ²
Coverage	2.2 panel/m ²
Textured unit weight	3.0 kg

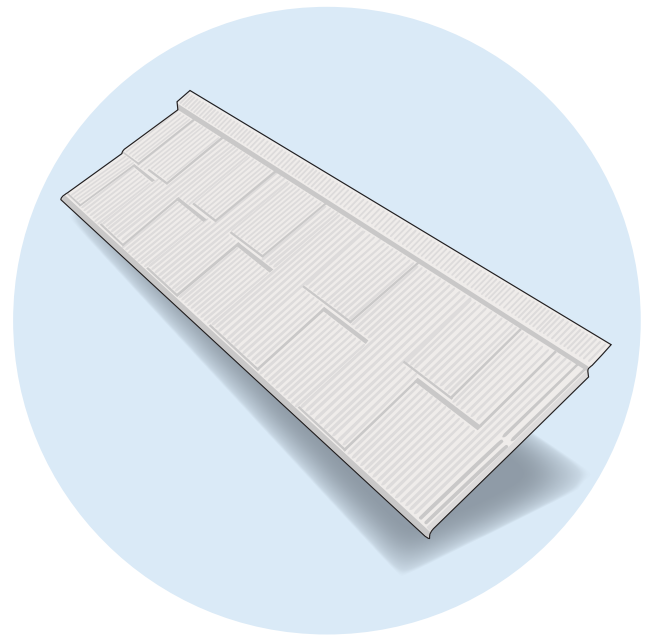

Dimensions and weights given are nominal.

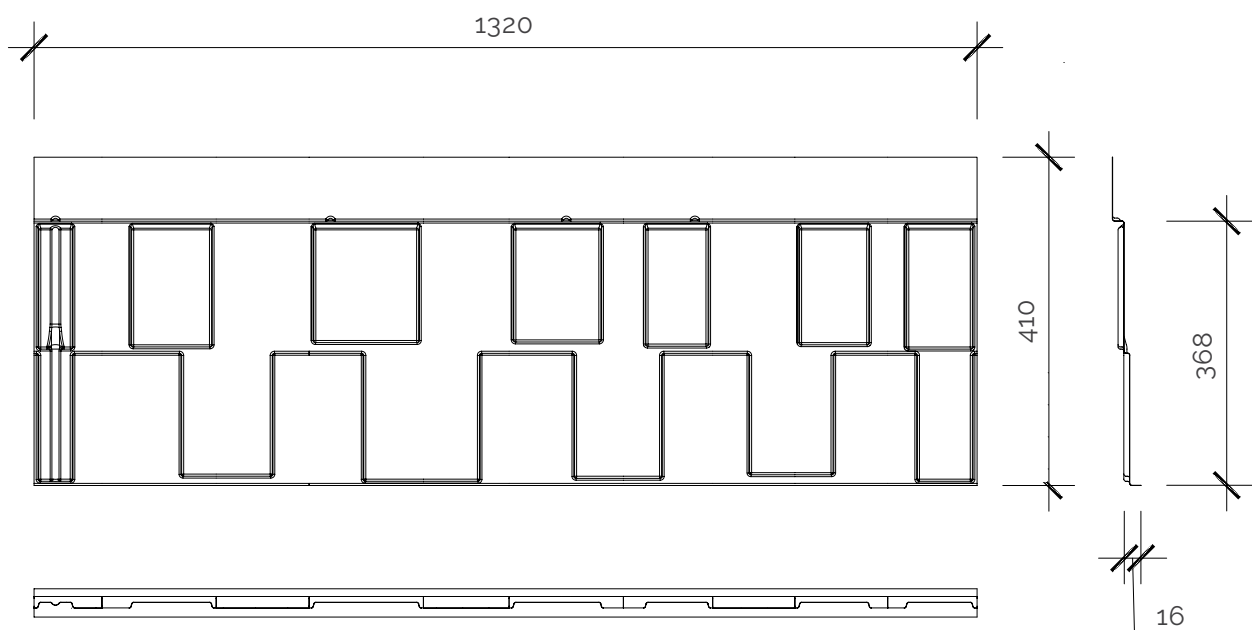

The worry-proof roof.®

Gerard Senator Panel Installation – Nailing Position

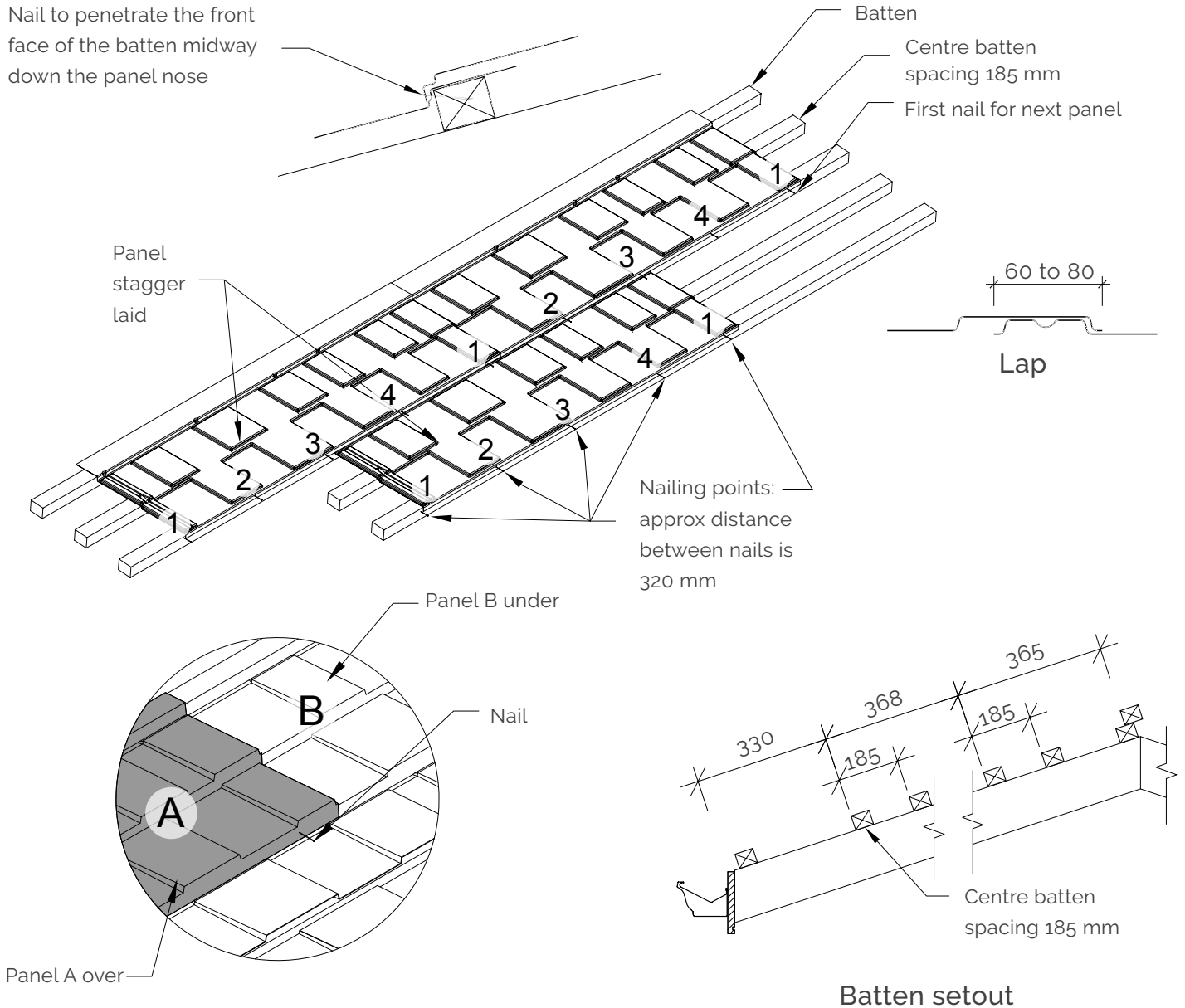

Fixing

- The nose of each panel is held down at 5 points.
- This comprises 4 nails as per the diagrams plus the nailed overlap panel.

Fastening panels in Cyclone Areas

- Where a building has been designed outside the scope of NZS 3604. Panels on buildings with a wind load design of above 3.8 kPa should be fastened at approx 160 mm spacing (each module).

Gerard Rockport

Specific Installation Instructions

Roof pitch	15-90°
Overall length	1330 mm
Length of cover	1250 mm
Width of cover	368 mm
Upstand	20 mm
Roof cover/panel	0.46 m ²
Coverage	2.2 panel/m ²
Textured unit weight	3.0 kg

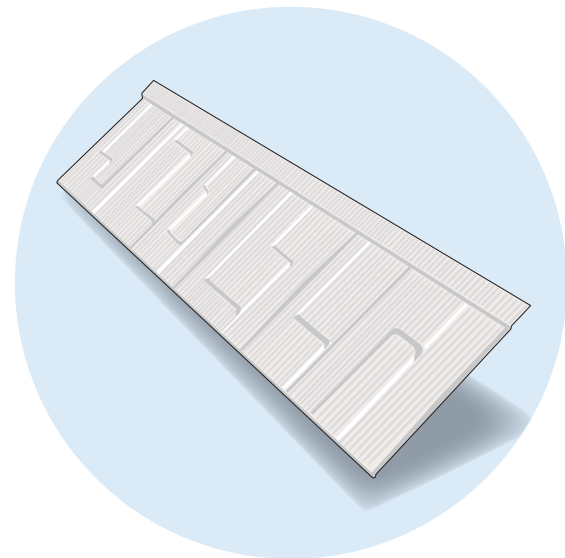

Dimensions and weights given are nominal.

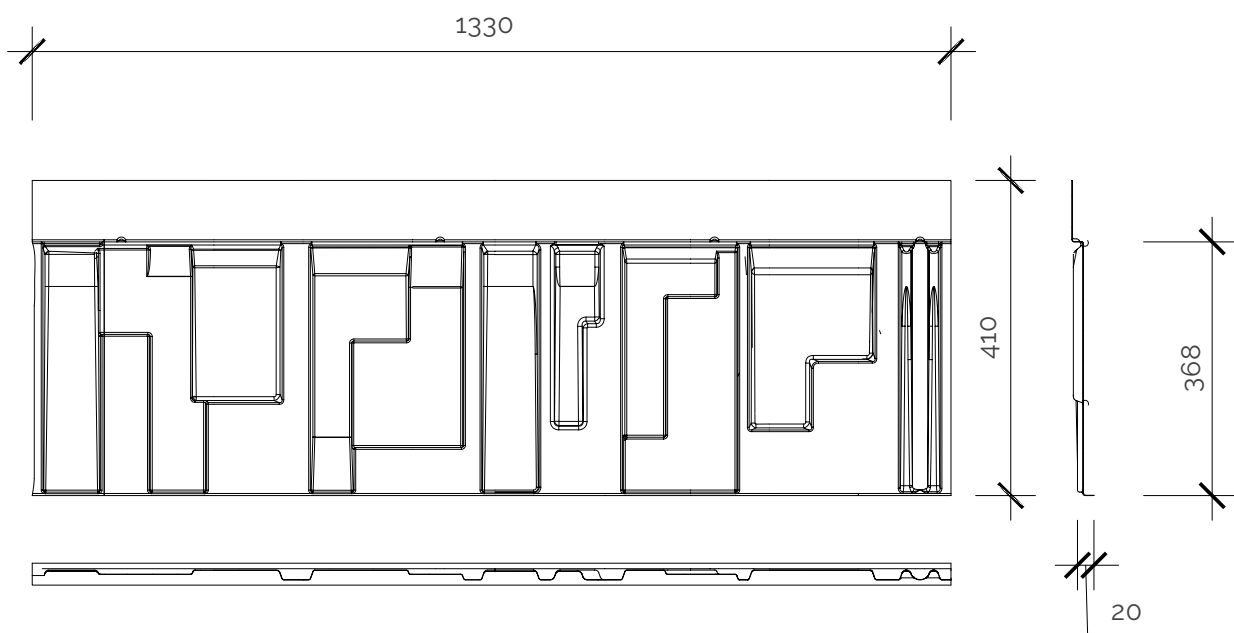

The worry-proof roof.®

Gerard Rockport Panel Installation – Nailing Position

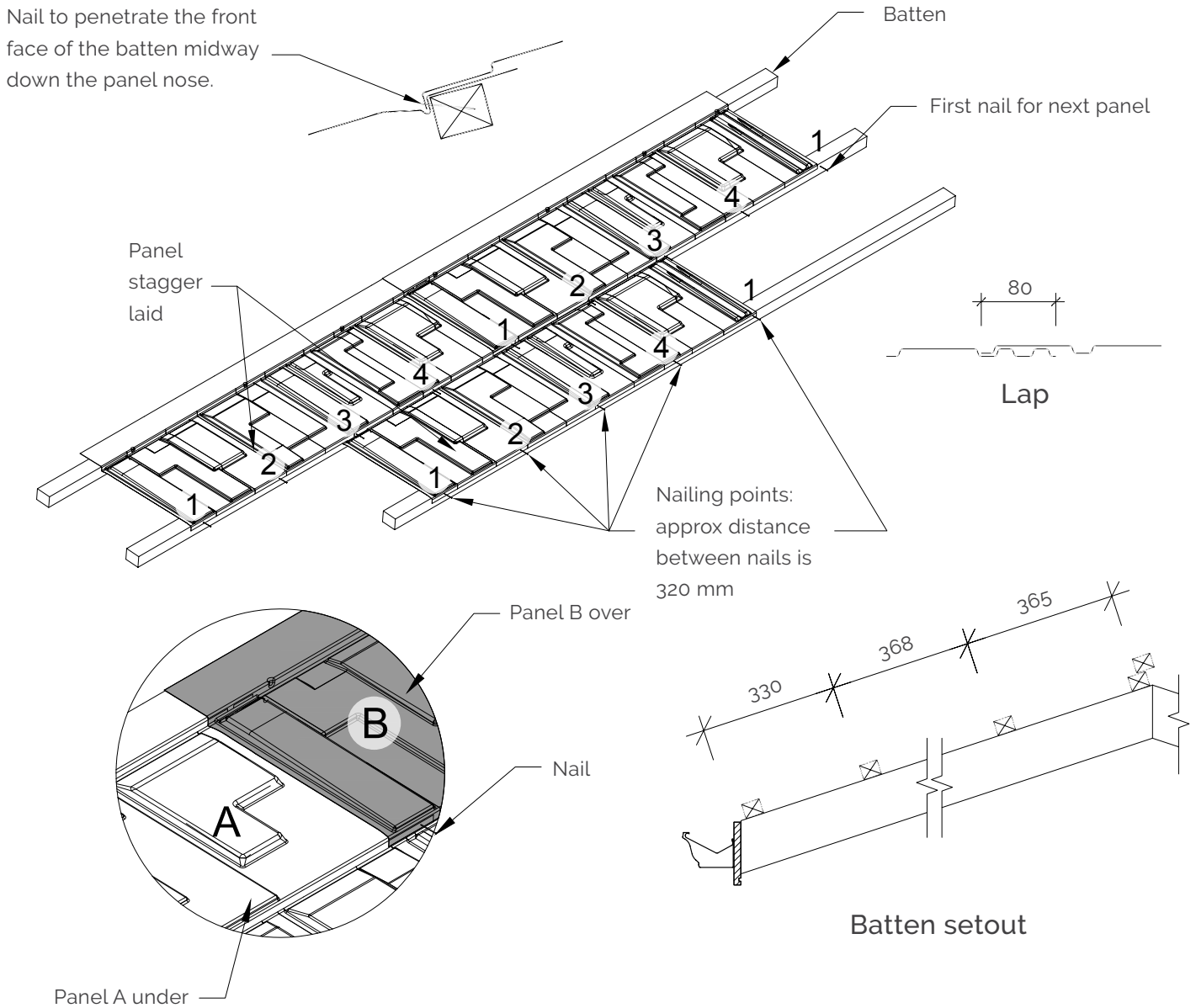

Fixing

- The nose of each panel is held down at 5 points.
- This comprises 4 nails as per the diagrams plus the nailed overlap panel.

Fastening panels in Cyclone Areas

- Where a building has been designed outside the scope of NZS 3604. Panels on buildings with a wind load design of above 3.8 kPa should be fastened at approx 160 mm spacing (each module).

Gerard Alpine

Specific Installation Instructions

Roof pitch	15-90°
Overall length	1335 mm
Length of cover	1260 mm
Width of cover	368 mm
Upstand	17 mm
Roof cover/panel	0.46 m ²
Coverage	2.2 panel/m ²
Textured unit weight	2.9 kg



Dimensions and weights given are nominal.

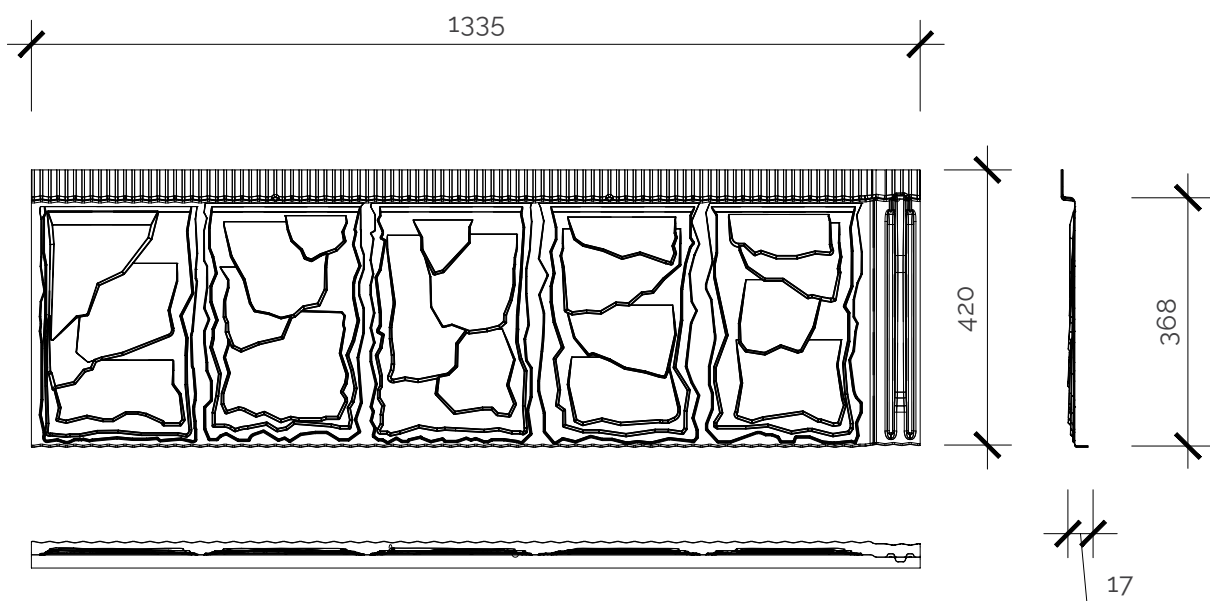

The worry-proof roof.®

Gerard Alpine Panel Installation – Nailing Position

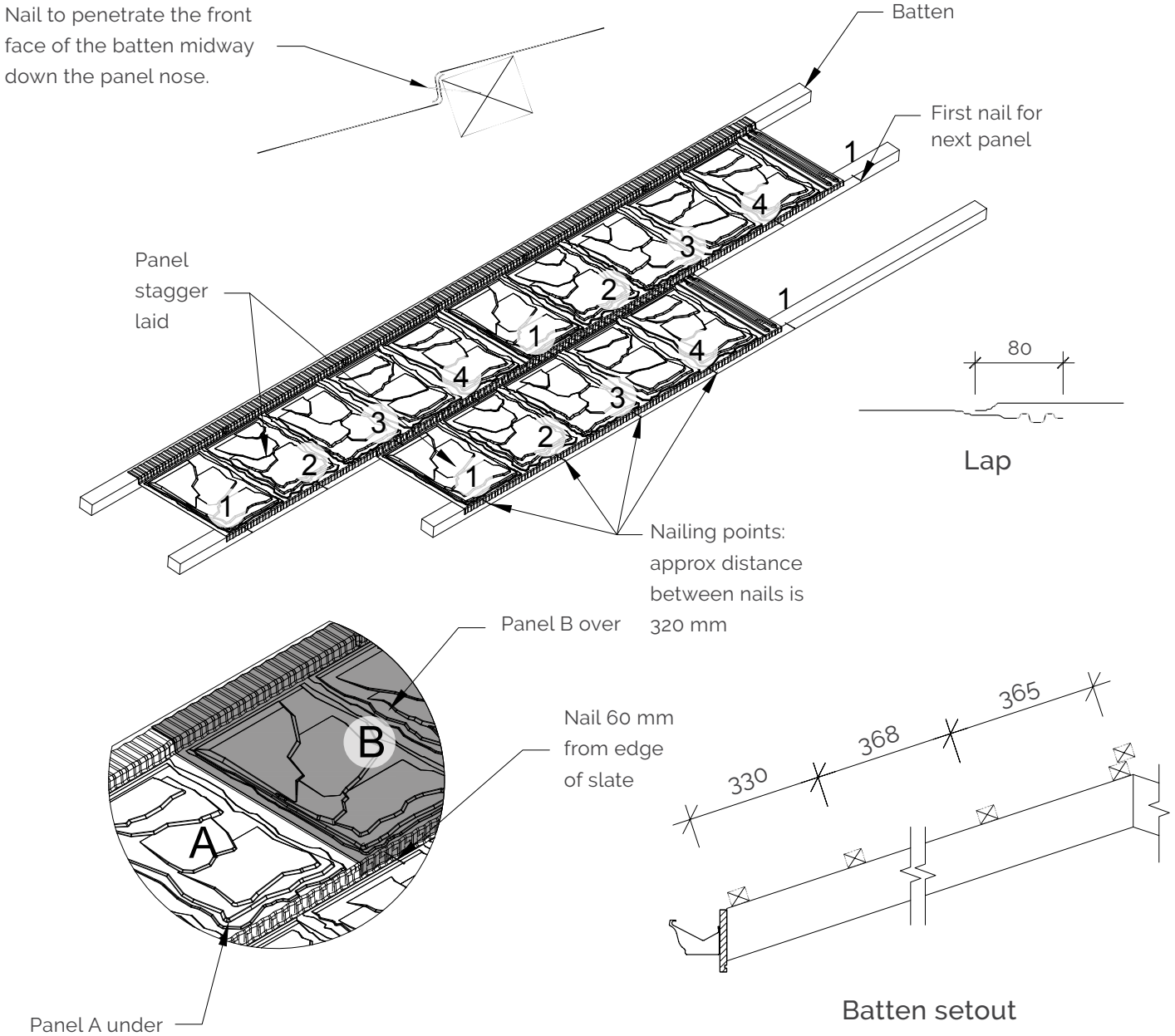

Fixing

- The nose of each panel is held down at 5 points.
- This comprises 4 nails as per the diagrams plus the nailed overlap panel.

Fastening panels in Cyclone Areas

- Where a building has been designed outside the scope of NZS 3604. Panels on buildings with a wind load design of above 3.8 kPa should be fastened at approx 160 mm spacing (each module).

Gerard Oberon

Specific Installation Instructions

Roof pitch	20-90°
Overall length	1310 mm
Length of cover	1230 mm
Width of cover	320 mm
Upstand	20 mm
Roof cover/panel	0.39 m ²
Coverage	2.54 panel/m ²
Textured unit weight	2.8 kg

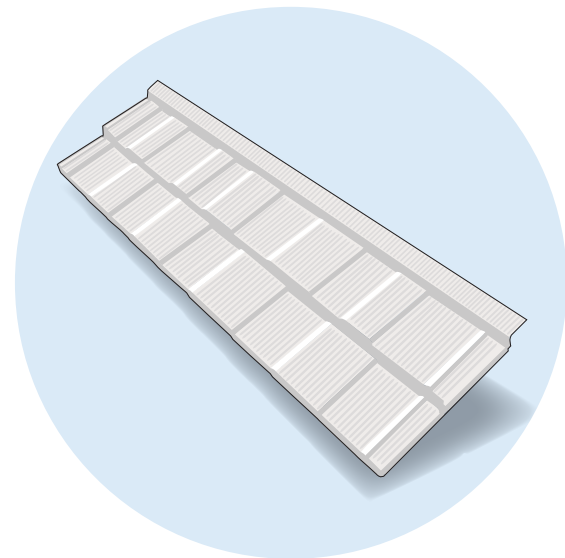

Dimensions and weights given are nominal.

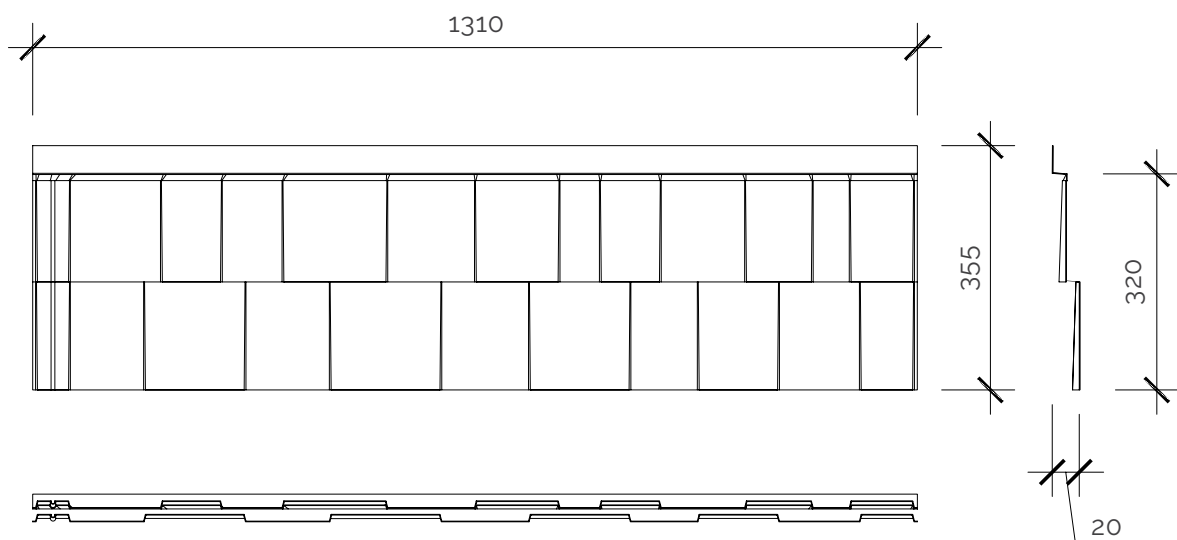

The worry-proof roof.®

Gerard Oberon Panel Installation – Nailing Position

Nail to penetrate the front face of the batten midway down the panel nose.

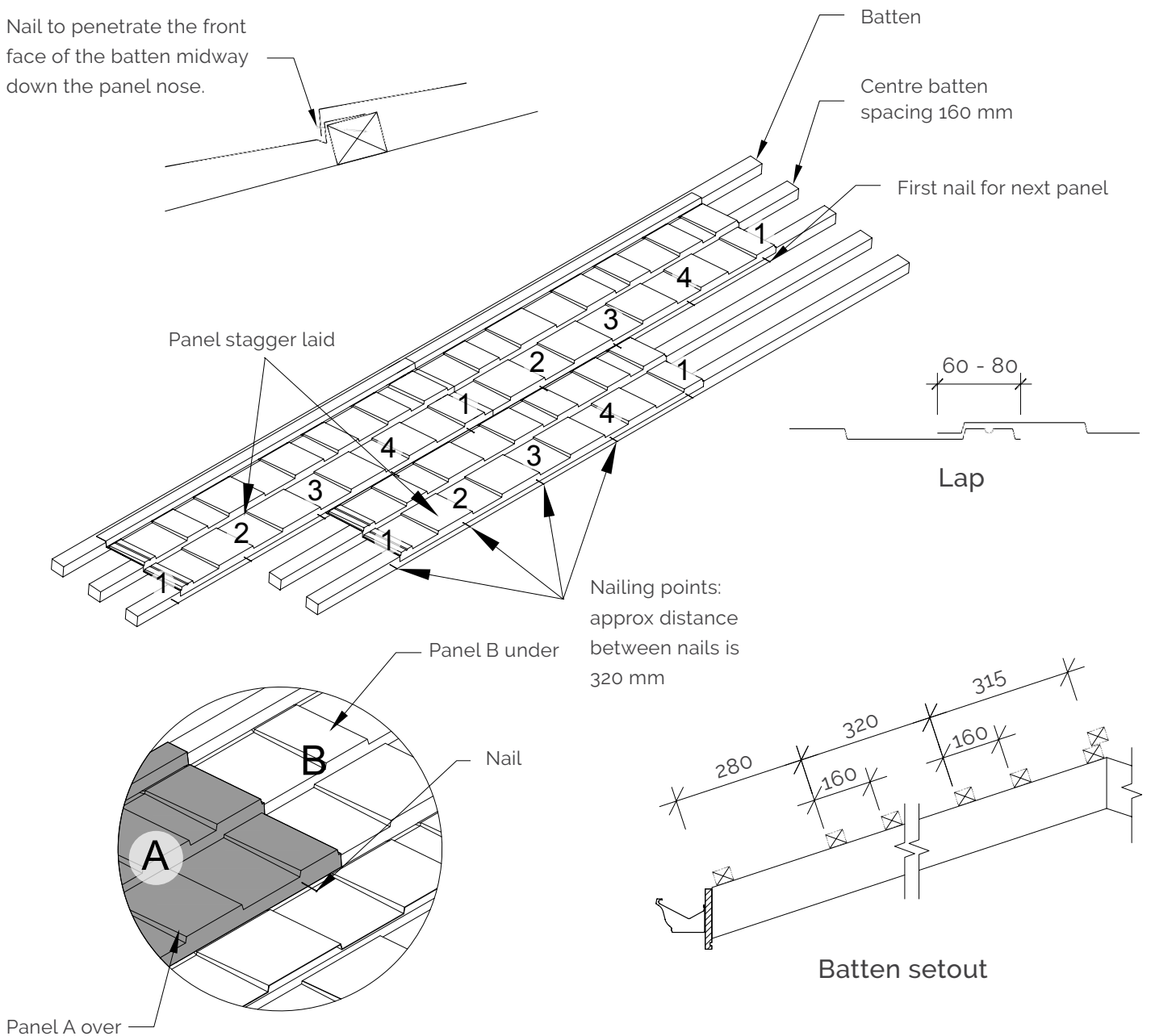

Fixing

- The nose of each panel is held down at 5 points.
- This comprises 4 nails as per the diagrams plus the nailed overlap panel.

Fastening panels in Cyclone Areas

- Where a building has been designed outside the scope of NZS 3604. Panels on buildings with a wind load design of above 3.8 kPa should be fastened at approx 160 mm spacing (each module).

Gerard Colortile

Specific Installation Instructions

Roof pitch	12-90°
Overall length	1330 mm
Length of cover	1257 mm
Width of cover	369 mm
Upstand	28 mm
Roof cover/panel	0.46 m ²
Coverage	2.2 panel/m ²
Textured unit weight	2.9 kg
Satin unit weight	2.1 kg

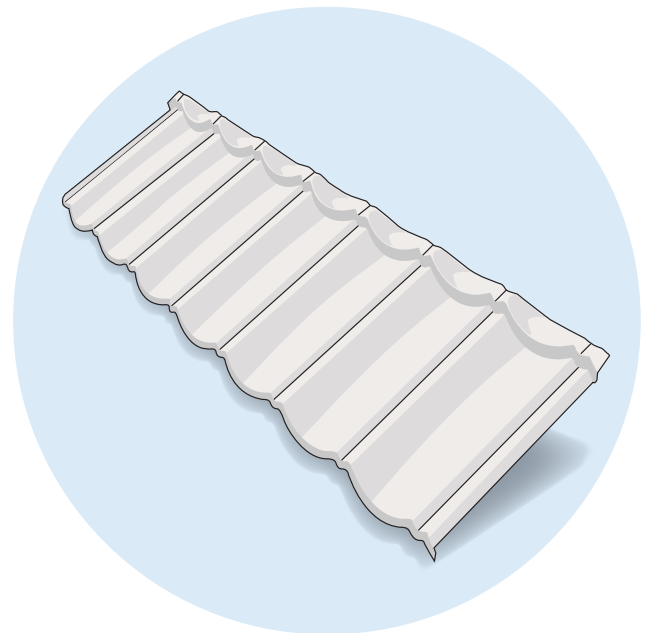

Dimensions and weights given are nominal.

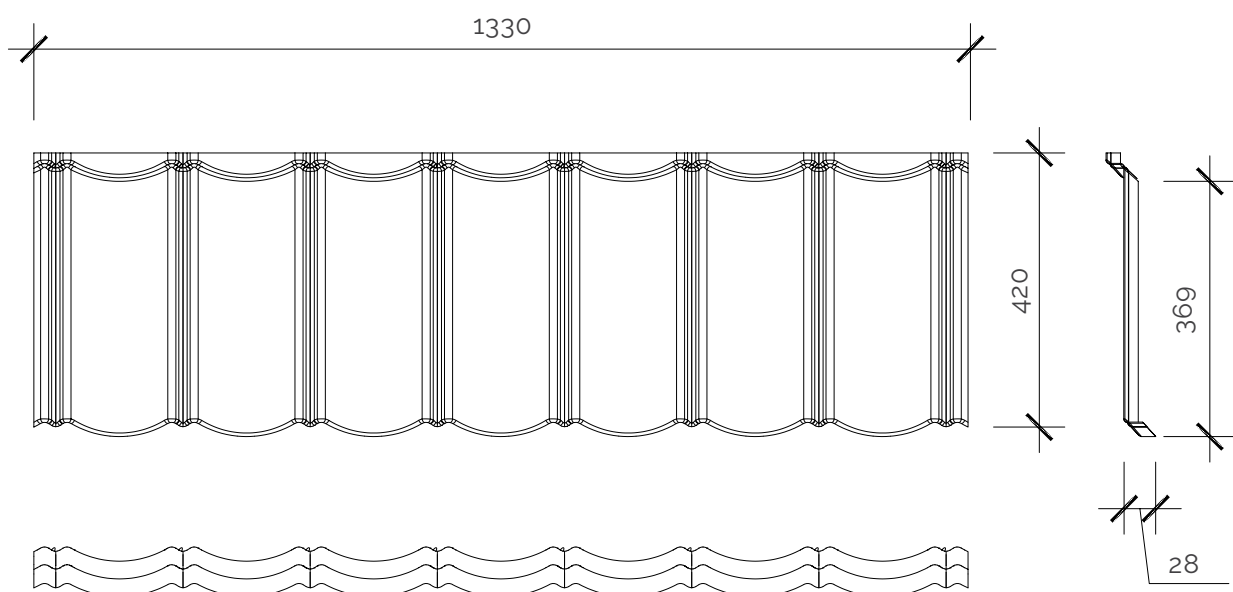

The worry-proof roof.®

Gerard Colortile Installation – Nailing Position

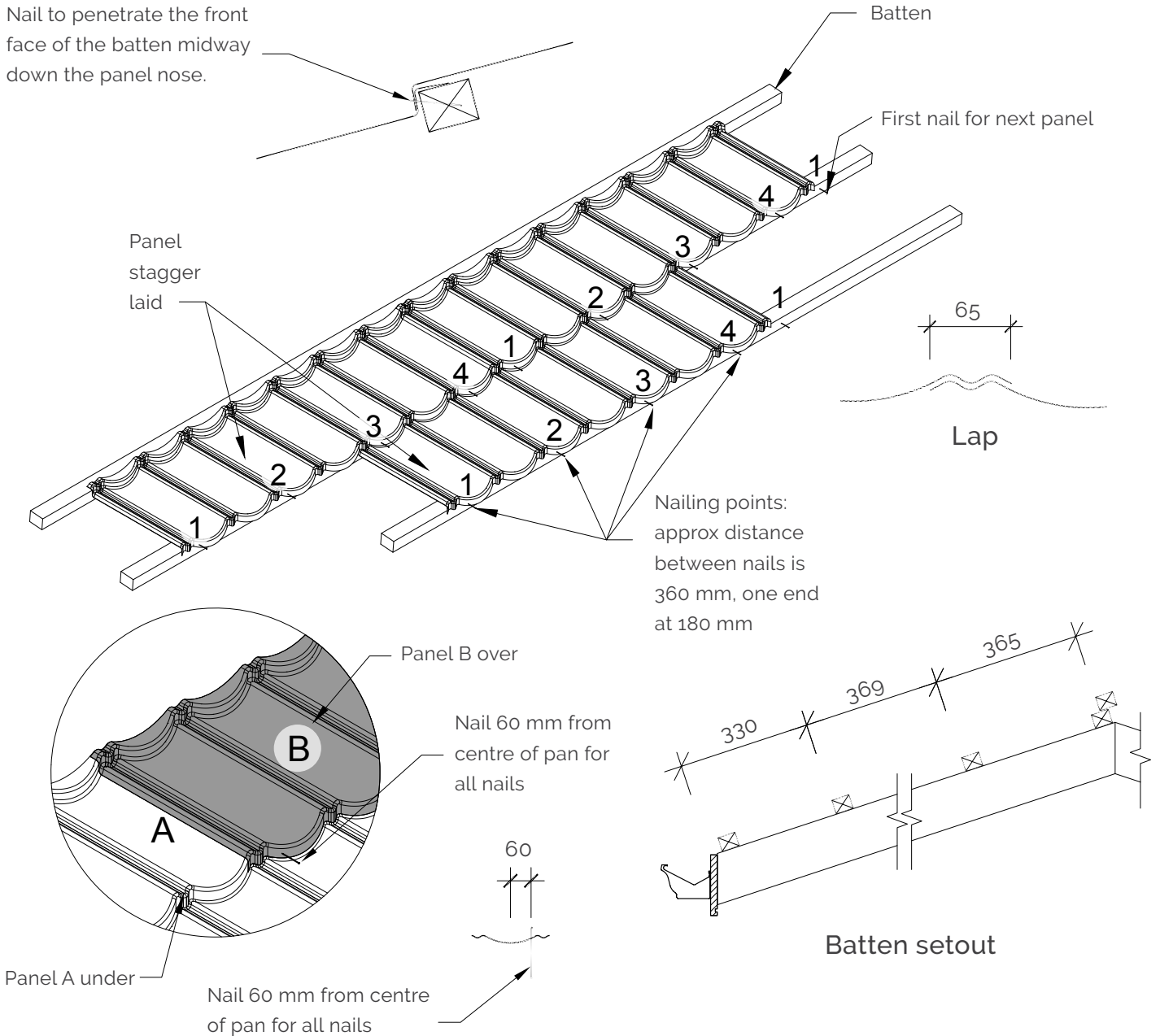

Fixing

- The nose of each panel is held down at 5 points.
- This comprises 4 nails as per the diagrams plus the nailed overlap panel.

Fastening Panels in Cyclone Areas

- Where a building has been designed outside the scope of NZS 3604. Panels on buildings with a wind load design of above 3.8 kPa should be fastened at approx 160 mm spacing (each module).

Gerard Milano

Specific Installation Instructions

Roof pitch	12-90°
Overall length	1330 mm
Length of cover	1215 mm
Width of cover	368 mm
Upstand	24 mm
Roof cover/panel	0.45 m ²
Coverage	2.2 panel/m ²
Textured unit weight	2.9 kg

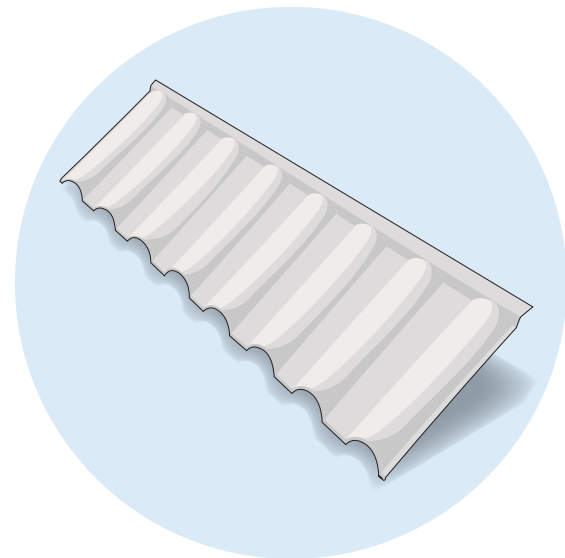

Dimensions and weights given are nominal.

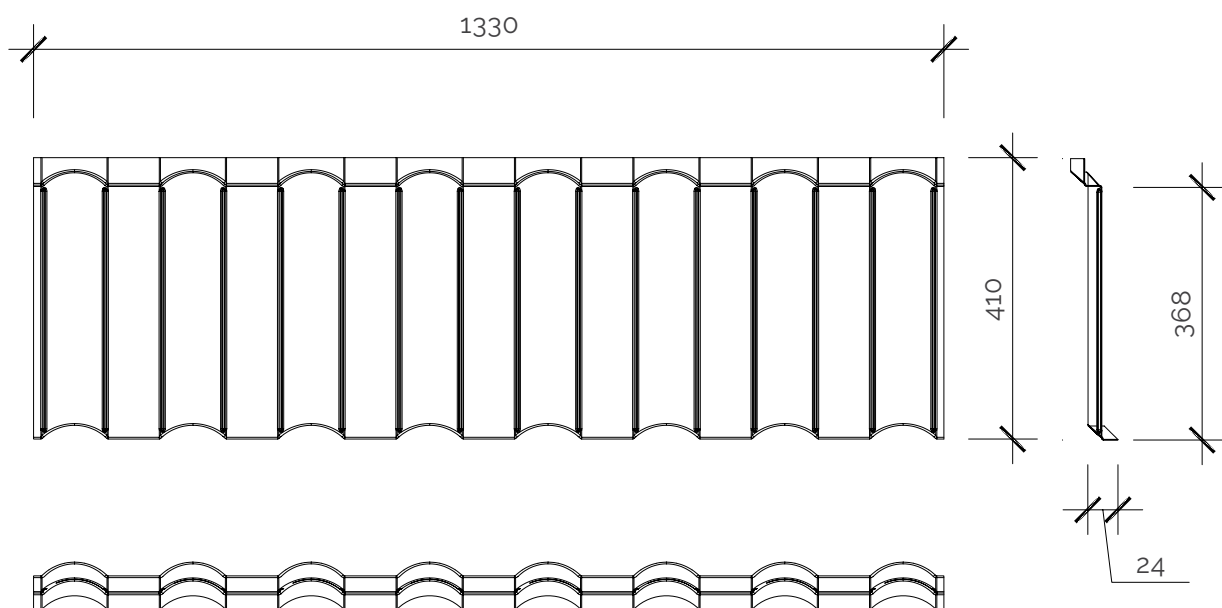

The worry-proof roof.®

Gerard Milano Panel Installation – Nailing Position

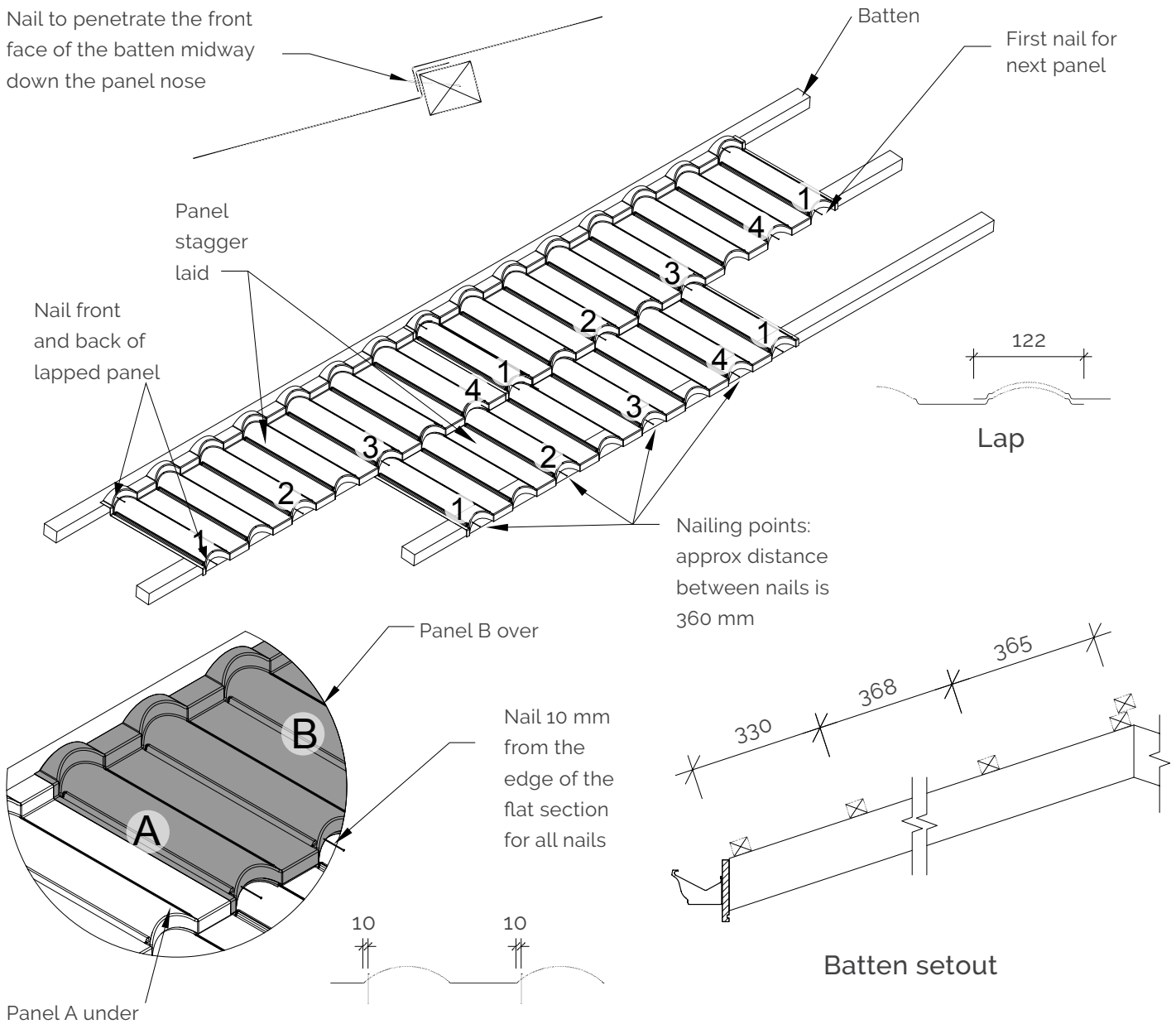

Fixing

- The nose of each panel is held down at 5 points.
- This comprises 4 nails as per the diagrams plus the nailed overlap panel.
- Nail front and back of lapped panel.

Fastening panels in Cyclone Areas

- Where a building has been designed outside the scope of NZS 3604. Panels on buildings with a wind load design of above 3.8 kPa should be fastened at approx 160 mm spacing (each module).

Gerard Tuffcoat

Specific Installation Instructions

Roof pitch	12-90°
Overall length	1320 mm
Length of cover	1257 mm
Width of cover	369 mm
Upstand	28 mm
Roof cover/panel	0.46 m ²
Coverage	2.2 panel/m ²
Textured unit weight	2.9 kg
Satin unit weight	2.1 kg

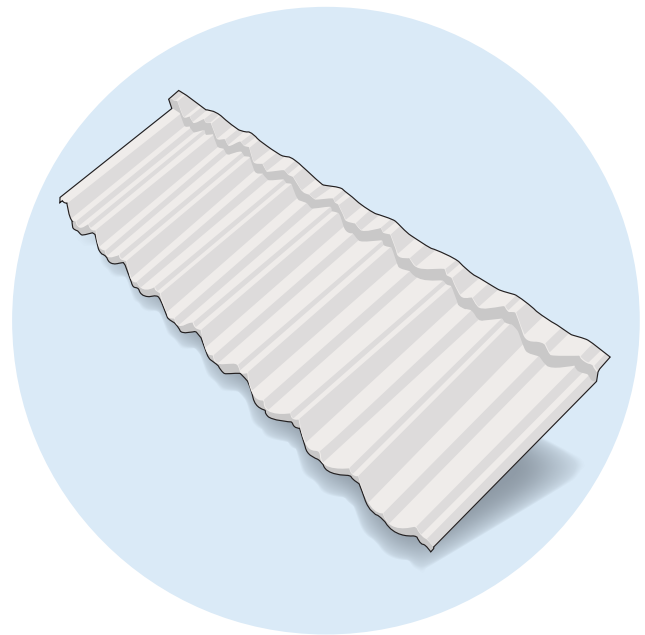

Dimensions and weights given are nominal.

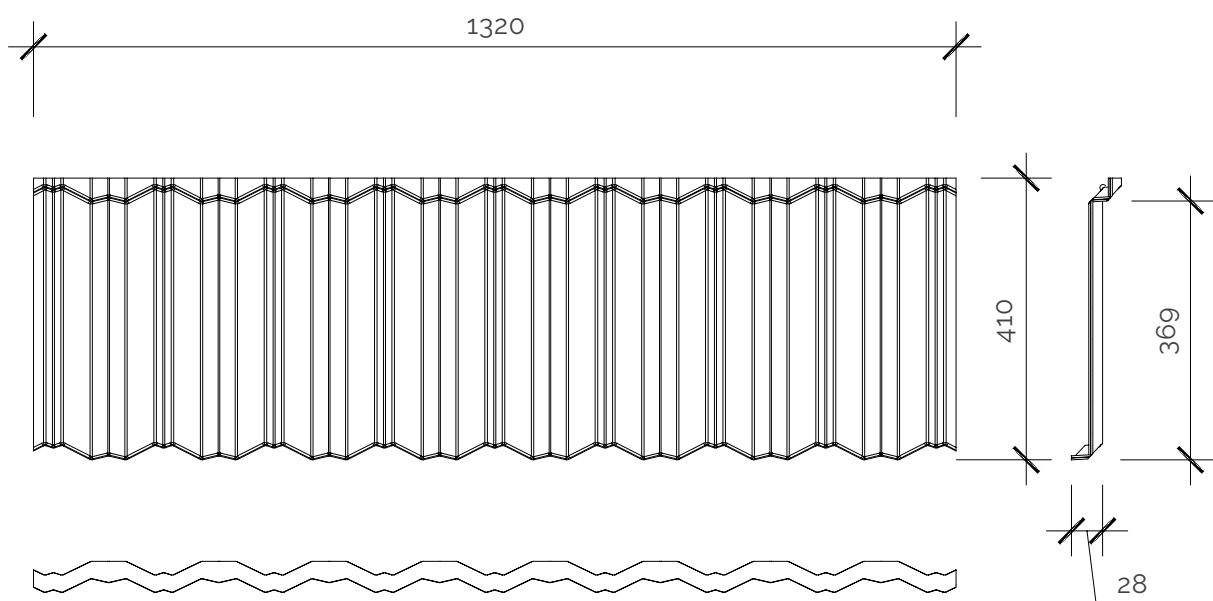

The worry-proof roof.®

Gerard Tuffcoat Panel Installation – Nailing Position

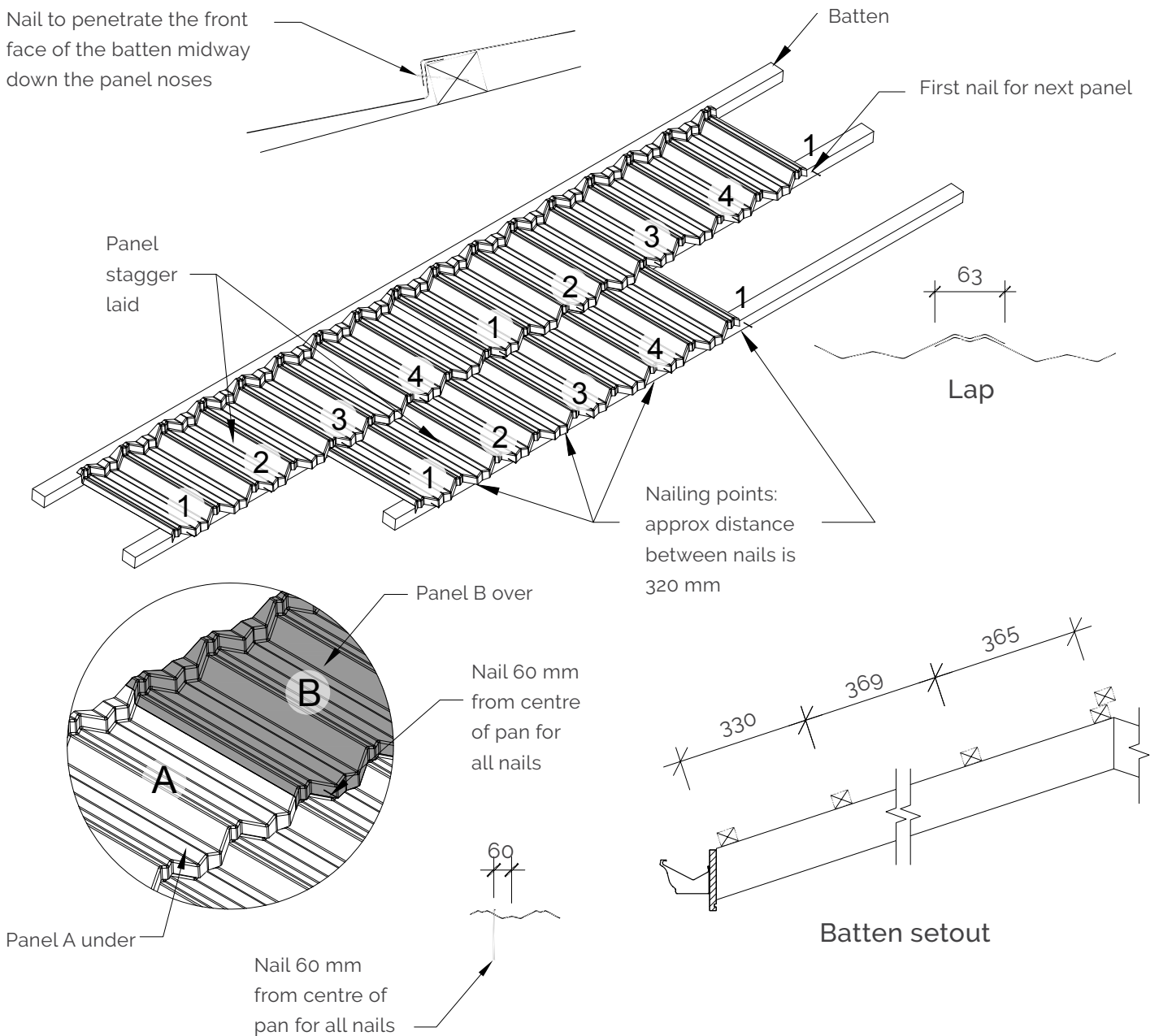

Fixing

- The nose of each panel is held down at 5 points.
- This comprises 4 nails as per the diagrams plus the nailed overlap panel.

Fastening panels in Cyclone Areas

- Where a building has been designed outside the scope of NZS 3604. Panels on buildings with a wind load design of above 3.8 kPa should be fastened at approx 160 mm spacing (each module).